



PNOT J10100-2016
Révision : b
14/03/2018

NOTICE DE MONTAGE ET D'UTILISATION
ASSEMBLY INSTRUCTIONS AND USER GUIDE
MONTAGE- EN GEBRUIKSHANDLEIDING
AUFBAU-UND BENUTZUNGS-ANLEITUNG

AERATION LATÉRALE 6m POUR SERRE DE JARDIN
ROLL-UP SIDE VENTILATION 6m FOR HOBBY GREENHOUSE
ZIJVENTILATIE 6m VOOR TUINKASSEN
SEITLICHE BELÜFTUNG (6 m) FÜR KLEINGEWÄCHSHAUS

EN CAS DE RECLAMATION AVEC NOS PRODUITS, CONTACTEZ VOTRE REVENDEUR ET COMPLETEZ LA FICHE DE RECLAMATION (VOIR AU DOS).

IN CASE OF DISSATISFACTION WITH OUR PRODUCTS, PLEASE CONTACT YOUR SALES OUTLET AND FILL IN THE "COMPLAINT SHEET" (see behind)

NEEM VOOR KLACHTEN CONTACT OP MET UW VERKOOPPUNT, MET HET BIJGAANDE "KLACHTENFORMULIER" (kijk op de achterkant van deze handleiding)

FÜR JEDE REKLAMATION BITTEN WIR SIE IHRE VERKAUFSTELLE MIT DEM BEILIEGENDEN REKLAMATIONSFORMULAR ZU KONTAKTIEREN.

INSTRUCTIONS DE POSE, D'UTILISATION, D'ENTRETIEN ET DE MAINTENANCE

RECOMMANDATIONS GENERALES

Vous venez de commander une serre RICHEL et nous vous en remercions. Veuillez consulter scrupuleusement cette notice et respecter les consignes de pose et d'utilisation qui sont indiquées. Il est très important de lire toute la notice avant de commencer le montage.

Leur non-respect dégraderait le vendeur de toute responsabilité.

UN MONTAGE DE MAUVAISE QUALITE PEUT INFLUER CONSIDERABLEMENT SUR LA RESISTANCE DE LA SERRE.

RECEPTION DU MATERIEL

Nous vous recommandons de vérifier le contenu des colis à l'aide du tableau récapitulatif de pièces que vous trouverez en début de notice de montage.

INSTRUCTIONS FOR ASSEMBLY, USE, CARE AND MAINTENANCE

GENERAL RECOMMENDATIONS

You have just ordered a RICHEL greenhouse. Please read this instruction carefully and follow the advice given concerning the construction, use, care and maintenance. The supplier will not accept responsibility in the event of non compliance.

POOR CONSTRUCTION QUALITY CAN CONSIDERABLY REDUCE THE STRUCTURAL RESISTANCE OF THE GREENHOUSE.

RECEIVING THE MATERIAL

It is recommended to verify the contents of the packages with the help of the summary table that you will find at the beginning of the assembly instructions guide.

INSTRUCTIES VOOR INSTALLATIE, GEBRUIK, REINIGING EN ONDERHOUD

ALGEMENE AANBEVELINGEN

U heeft een RICHEL kas besteld en wij willen u daarvoor bedanken. Neem zorgvuldig deze handleiding door en neem de installatie- en gebruiksinstructies die erin staan vermeld in acht. Het is belangrijk om de handleiding volledig te lezen voordat u met de montage begint.

In geval van niet in acht nemen van de instructies vervalt iedere verantwoordelijkheid van de verkoper.

EEN SLECHTE MONTAGE VAN DE KAS KAN DE WEERSTAND ERVAN AANZIENLIJK BEÏNVLOEDEN.

ONTVANGST VAN HET MATERIAAL

Wij raden u aan om de inhoud van de pakketten te verifiëren met behulp van de overzichtstabel met onderdelen die u in het begin van de montagehandleiding vindt.

INSTRUKTIONEN FÜR DIE BENUTZUNG, INSTANDHALTUNG UND WARTUNG

ALLGEMEINE EMPFEHLUNGEN

Sie haben einen RICHEL Gewächshaus bestellt ; bitte lesen Sie diese Beschreibung aufmerksam durch und beachten Sie die darin gegebenen Anweisungen zur Aufstellung, Benutzung, Instandhaltung und Wartung. Lesen Sie vor Montage unbedingt die gesamte Bedienungsanleitung!











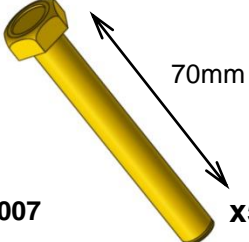
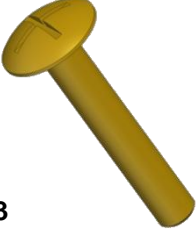



Die Nichtbeachtung entbindet den Verkäufer von jeglicher Verantwortung.

EINE MONTAGE VON SCHLECHTER QUALITÄT KANN SICH BETRÄCHTLICH AUF DIE STANDFESTIGKEIT DES GEWÄCHSHAUS AUSWIRKEN.

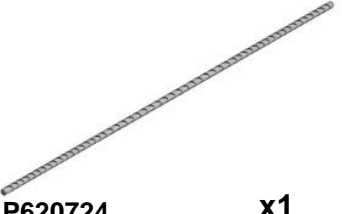

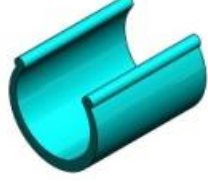

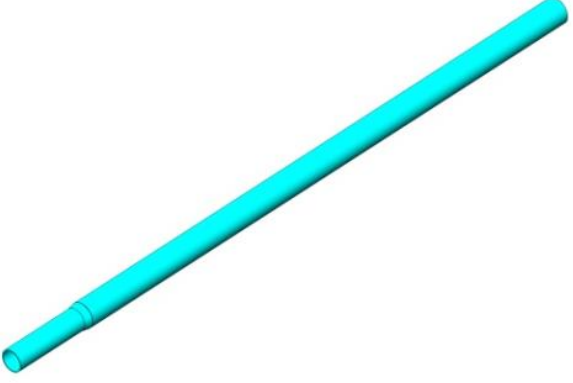







MATERIALANNAHME

Wir empfehlen Ihnen, den Inhalt der Pakete anhand der Stückliste, die Sie am Anfang der Montageanleitung finden, zu überprüfen.

LISTE DES PIÈCES
PARTS LIST
LIJST VAN ONDERDELEN
STÜCKLIST

 <p>P710007 x5</p>	 <p>P710193</p>	 <p>x6</p>	 <p>P410028 x3</p>
 <p>P620134 x5</p>	 <p>P710014 x5</p>	 <p>P620845 x3</p>	 <p>P510134 x3</p>
 <p>P730263 x1</p>	 <p>P710013 x45</p>	 <p>P620724 x1</p>	 <p>P743241 x2</p>
 <p>P510151 x4</p>	 <p>P620255 x16</p>	 <p>P710214 x1</p>	
 <p>P110542 x8</p>	 <p>P131137 x4</p>		

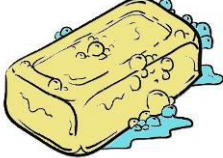
OUTILLAGE NECESSAIRE (Non fourni)
NECESSARY TOOLS (Not supplied)
BENODIGD GEREEDSCHAP (Niet meegeleverd)
BENÖTIGT WERKZEUGE (Nicht geliefert)

			
		 X 2	
			
			

CAS n°1: Si vous avez déjà monté la serre, il faut commencer par déterrer le film de couverture, puis le retirer.

CASE no. 1: If you have already assembled the hobby tunnel, start by taking the cover sheet out of the ground and removing it.

VOORBEELD nr. 1: Als u de kas al hebt opgebouwd, moet u beginnen met het uitgraven van het folie en het verwijderen.

FALL 1: Wenn Sie das Gewächshaus bereits komplett aufgebaut haben, müssen Sie zunächst die Eindeckfolie ausgraben und abnehmen.

CAS n°2: Si la serre est en cours de montage, il faut mettre en œuvre cette notice avant le bâchage.

CASE no. 2: If you are assembling the hobby tunnel, follow these instructions before putting the cover into place.

VOORBEELD nr. 2: Als de kas nog wordt opgebouwd, moet u deze instructies uitvoeren, voordat u de kas afdekt met folie.

FALL 2: Wenn Sie das Gewächshaus noch nicht komplett aufgebaut haben, führen Sie die in dieser Anleitung beschriebenen Schritte aus, bevor Sie die Eindeckfolie aufziehen.

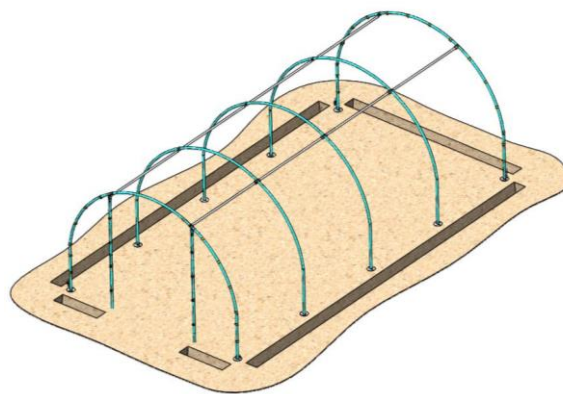
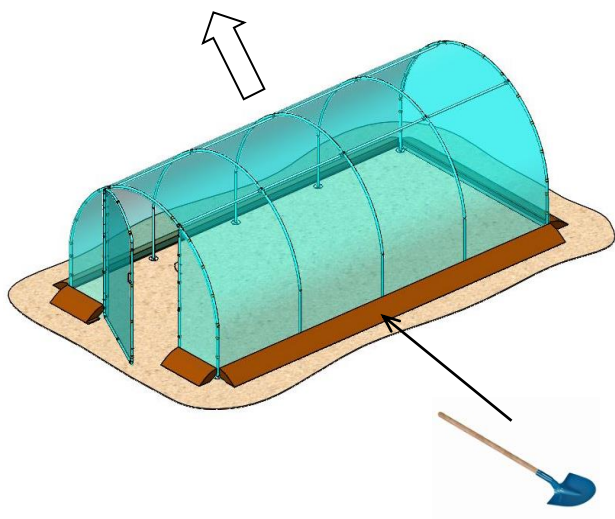

Vous pouvez vous aider avec le P620724
You can use P620724
Sie können P620724 verwenden
U kunt P'620724 gebruiken

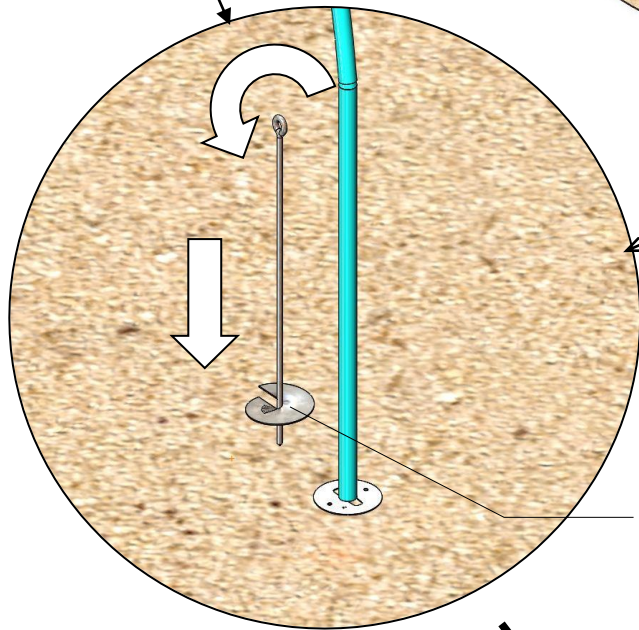
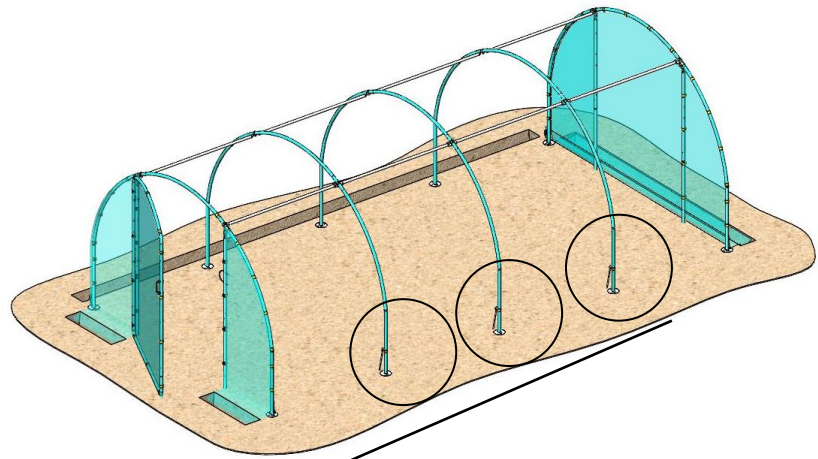

x3

P620845

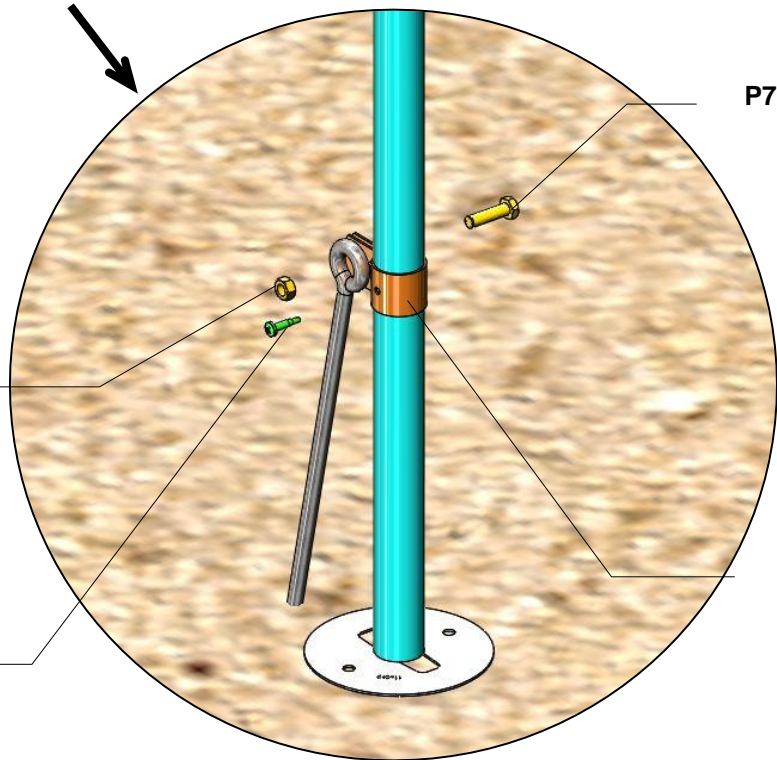

P710007

P710014

P620134

P710013

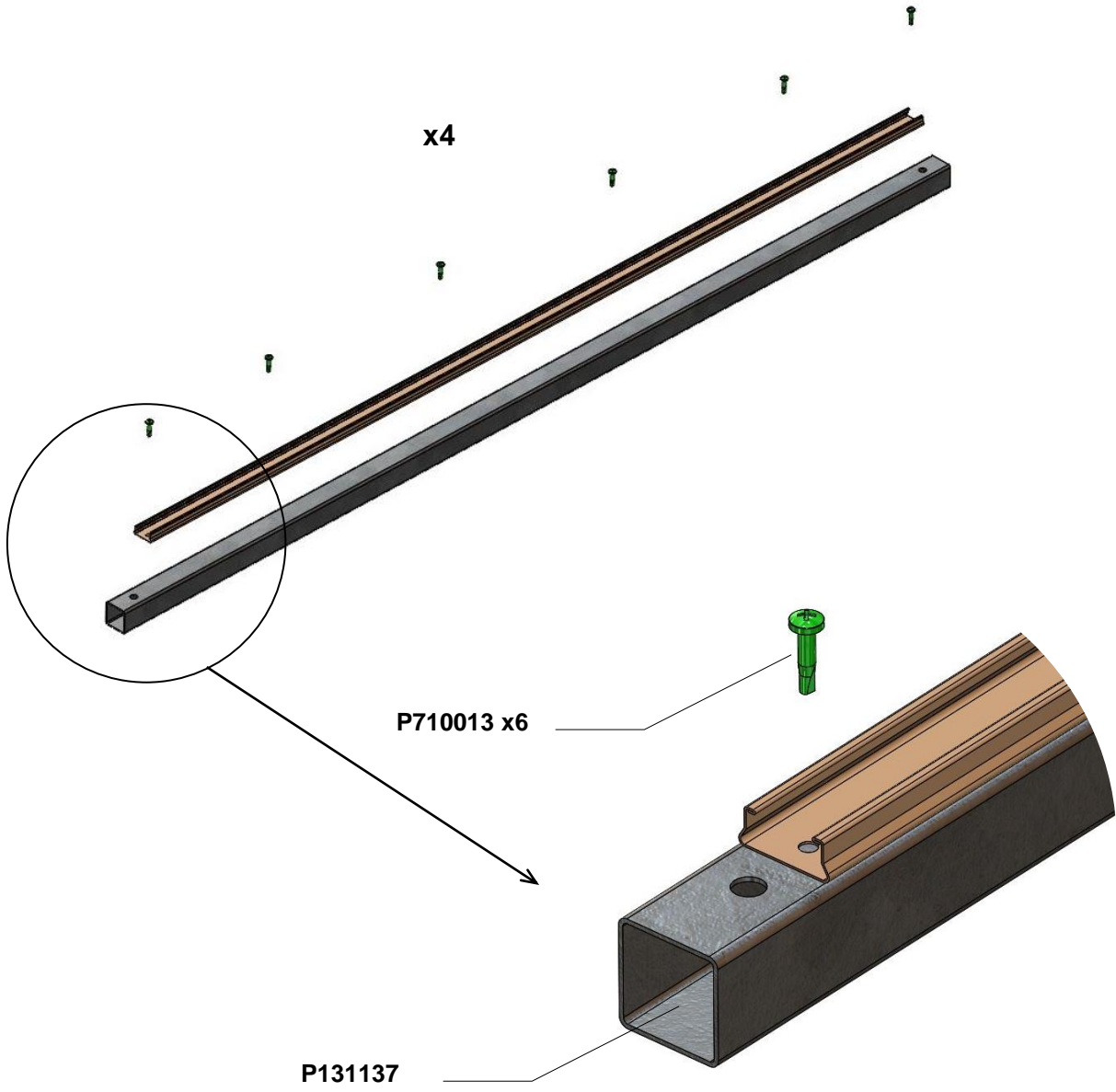

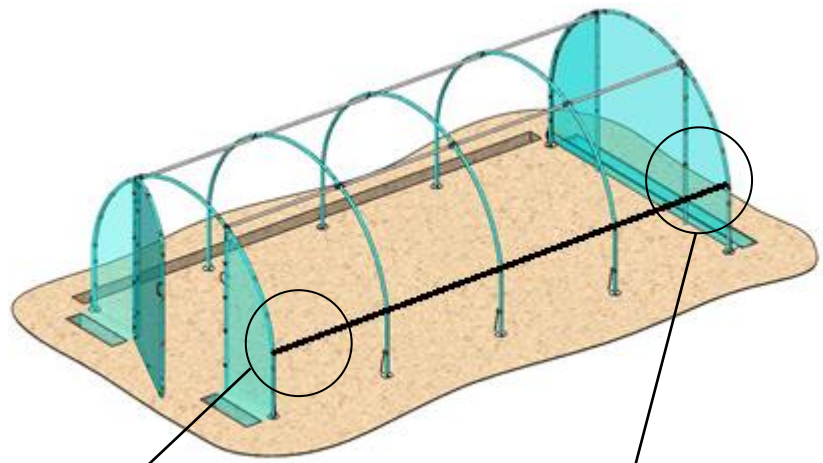

Vue extérieure
Exterior view
Buitenaanzicht
Außenansicht

x2

P620134

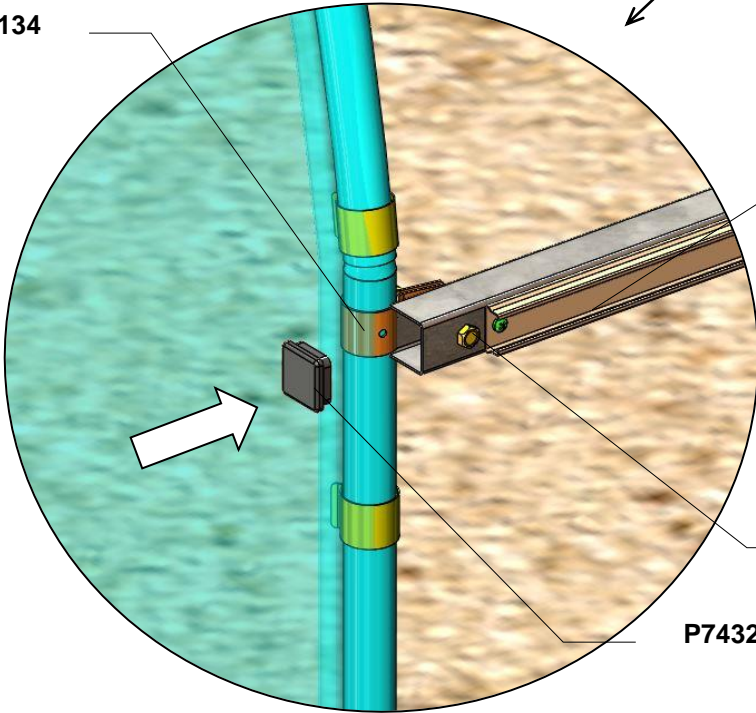

P131137
P510151
Assemblé
Assembled
Geassembleerd
Montiert

P710007

P743241

Vue intérieure
Interior view
Binnenaanzicht
Innenansicht

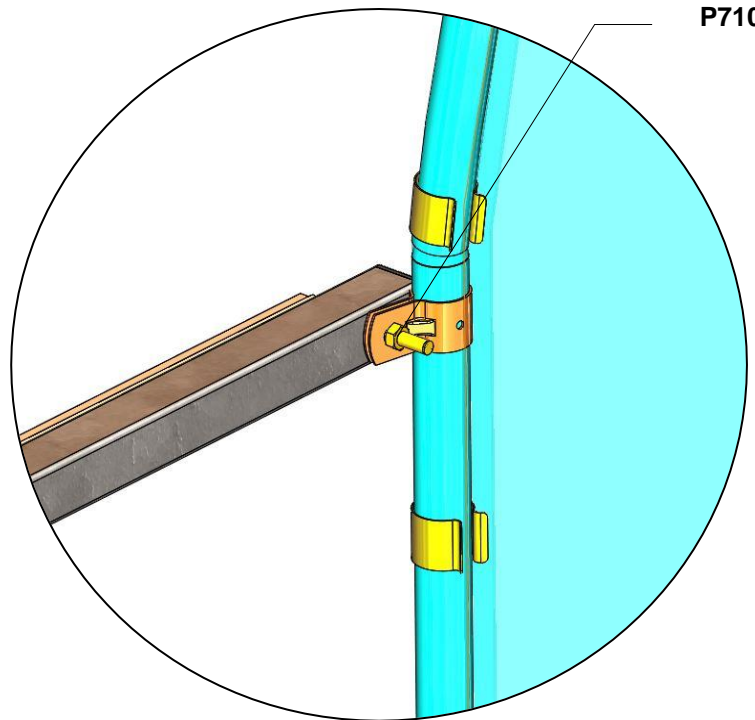

P710014

Vue intérieure
Interior view
Binnenaanzicht
Innenansicht

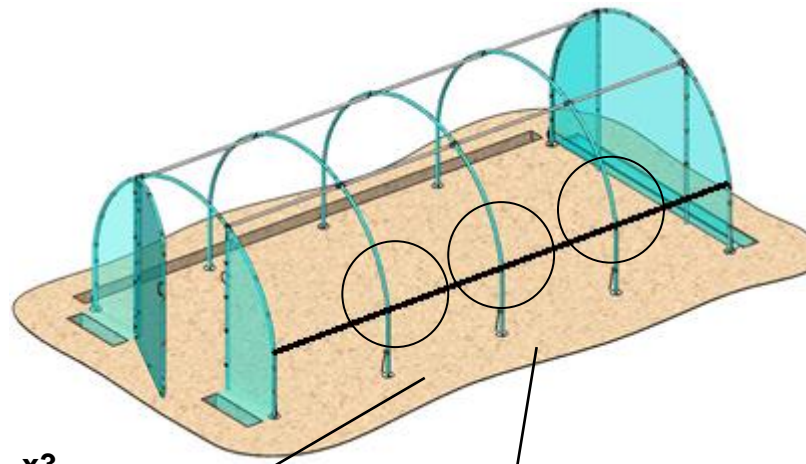

x3

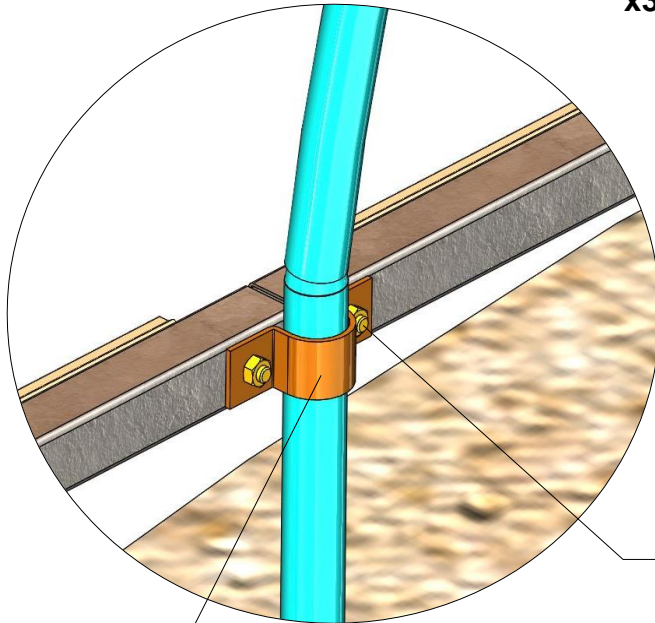

P410028

P710193 x2

Vue extérieure
Exterior view
Buitenaanzicht
Außenansicht

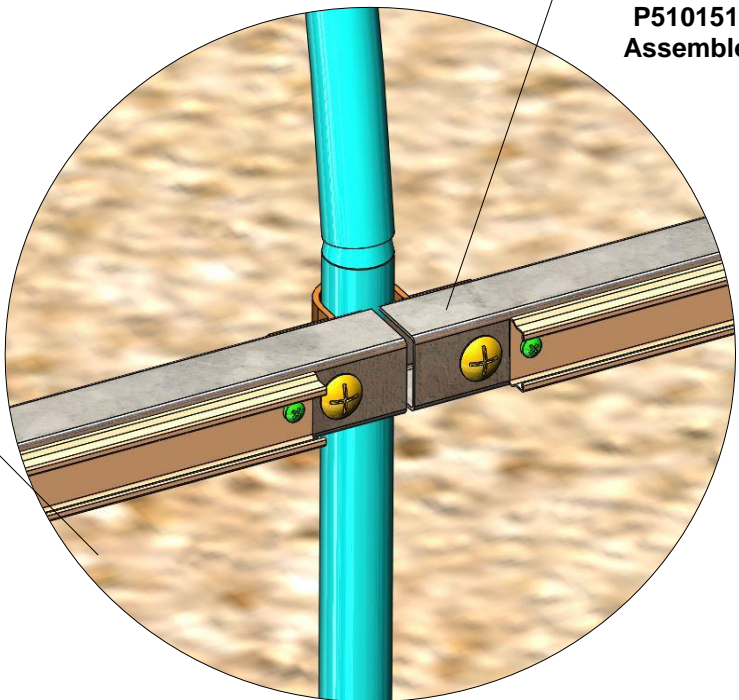

P131137
P510151
Assemblé

P131137
P510151
Assemblé
Assembled
Geassembleerd
Montiert

Si le profil est positionné au dessus de la jonction entre l'arceau et le pied, une vis autoforeuse est obligatoire pour chaque arceau.



If the section is positioned above the joint between the arch and the foot, a self-drilling screw is compulsory for each arch.

Als het profiel boven de verbinding tussen de boog en de poot wordt geplaatst, moet er verplicht gebruik worden gemaakt van een zelfborende schroef voor elke boog.

Wenn das Profil oberhalb der Verbindung zwischen Bogen und Fuß angebracht wird, muss für jeden Bogen eine selbstbohrende Schraube verwendet werden.

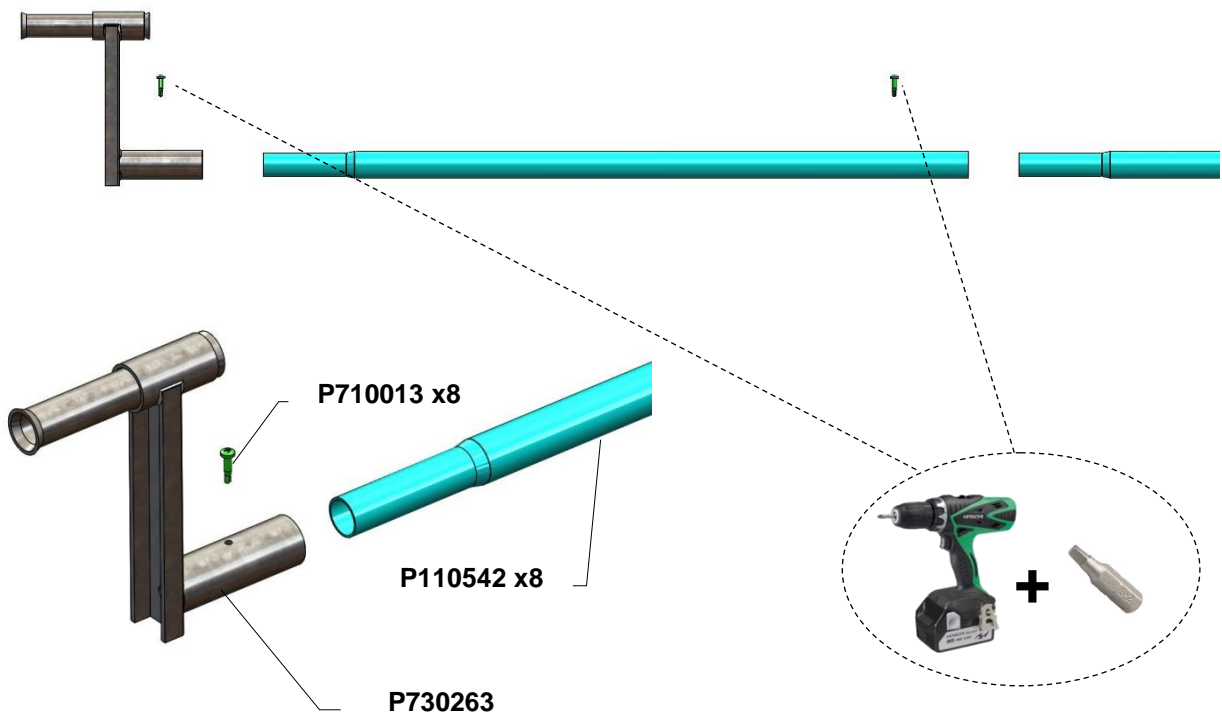
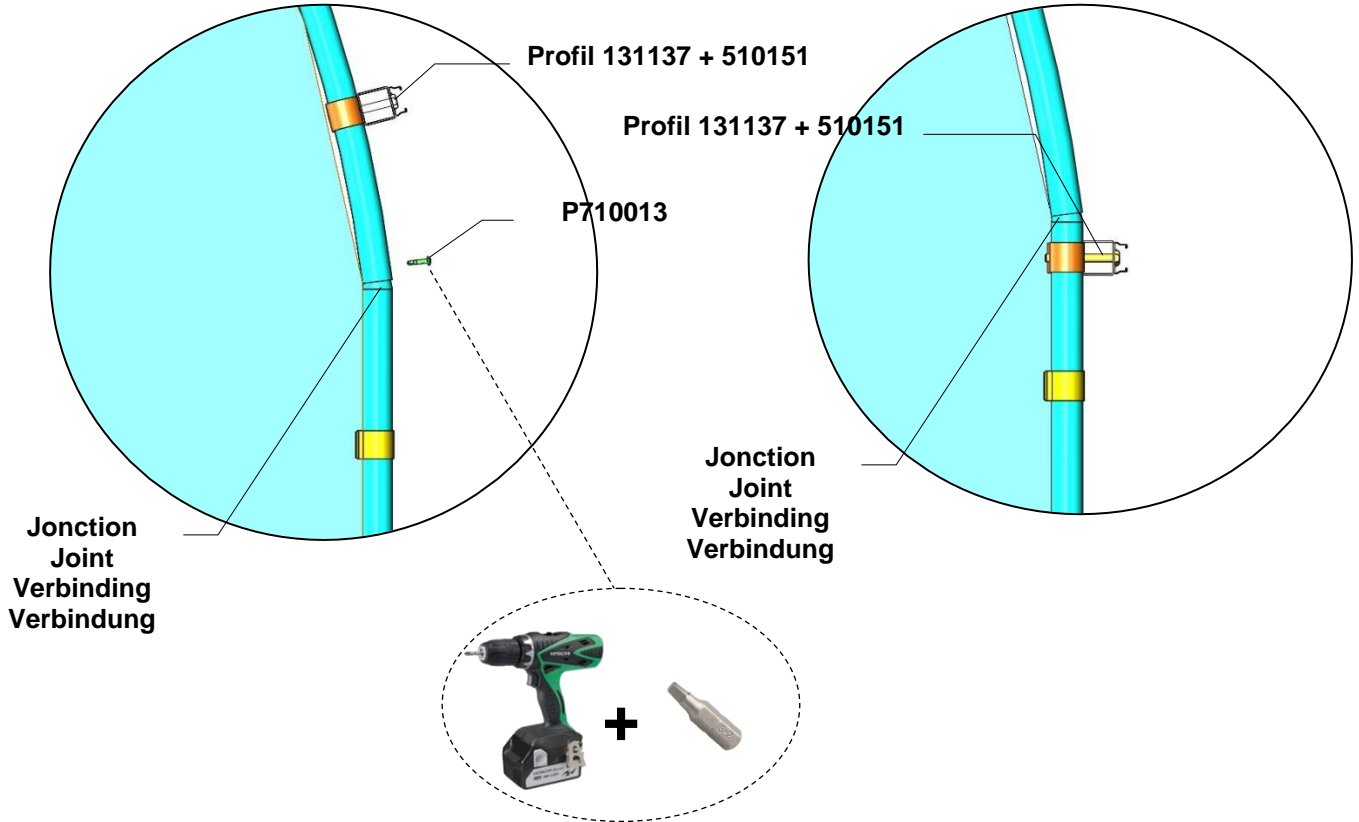



Mettre en place la couverture de la serre de jardin. Conformément à la notice de montage associée.

Install the cover on the hobby tunnel. Follow the corresponding assembly instructions.

Het folie van de tuinkas installeren. Volgens de meegeleverde montagevoorschriften.

Eindeckung des Kleingewächshauses aufziehen (entsprechend der zugehörigen Aufbauanleitung).

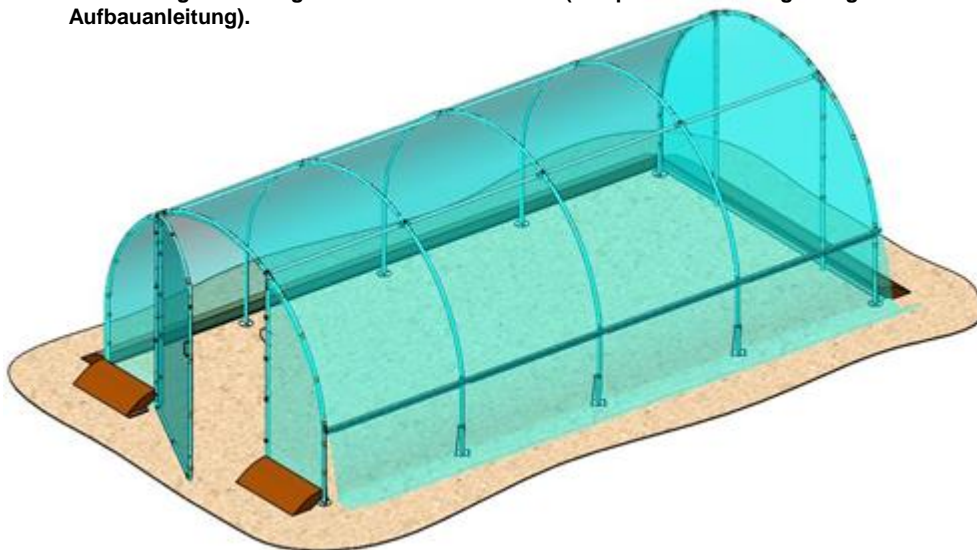

Laisser dépasser suffisamment le P110542 pour fixer la manivelle.

Allow the P110542 to protrude sufficiently to attach the crank handle.

Laat de P110542 voldoende naar buiten steken voor het bevestigen van de zwengel.

P110542 so weit überstehen lassen, dass Kurbel angebracht werden kann

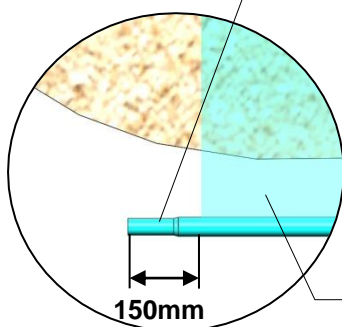

Film

150mm

Ouvrir la gaine sur la hauteur d'aération

Open the duct along the height of the vent.

De koker openen over de hele ventilatiehoogte

Ummantlung bis zur gewünschten Belüftungshöhe öffnen

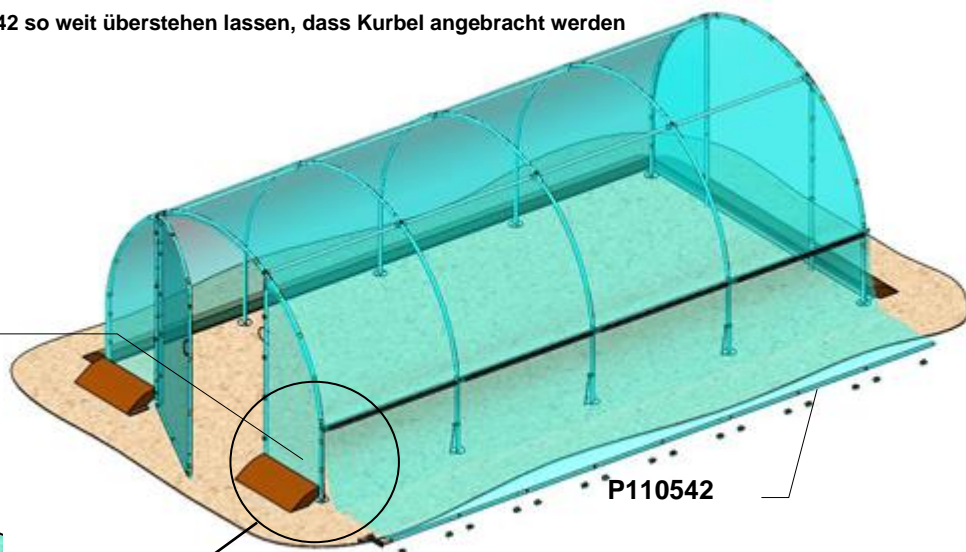

P110542

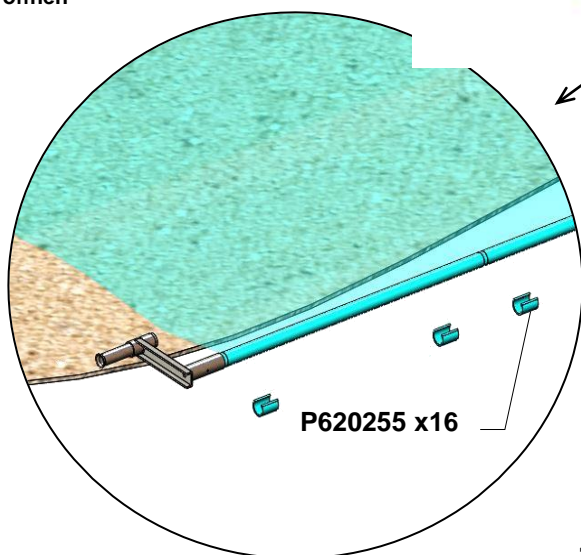

P620255 x16

Le film doit être clipsé de manière la plus rectiligne possible

The sheet must be clipped as straight as possible.

Het folie moet zo recht mogelijk worden vastgeklemd.

Die Folie muss so gerade wie möglich angeclipst werden

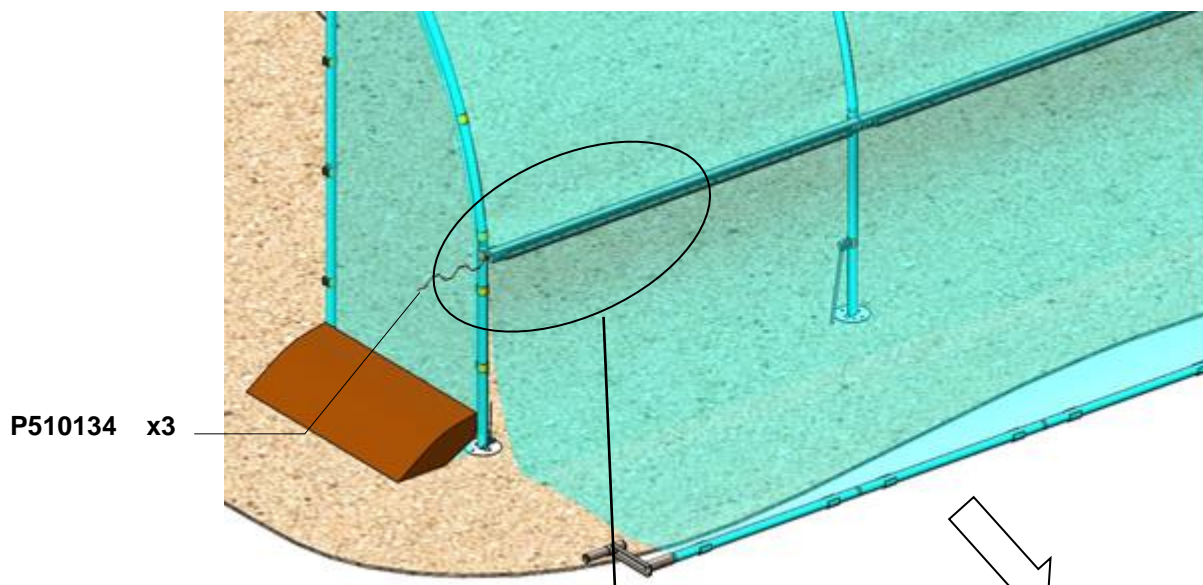

Tendre le film

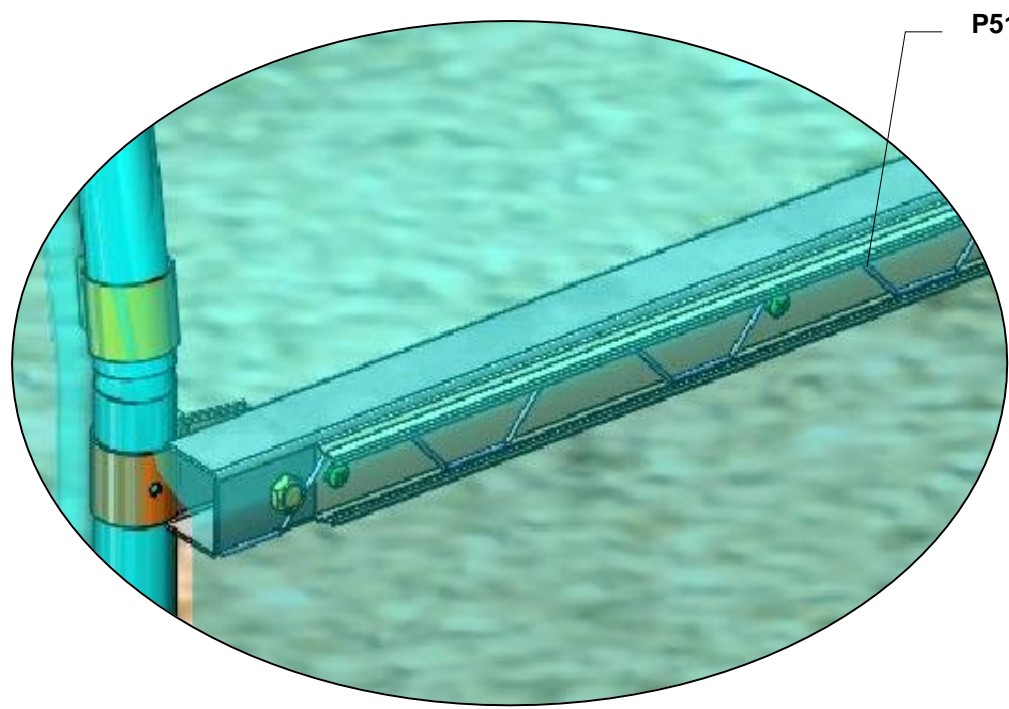

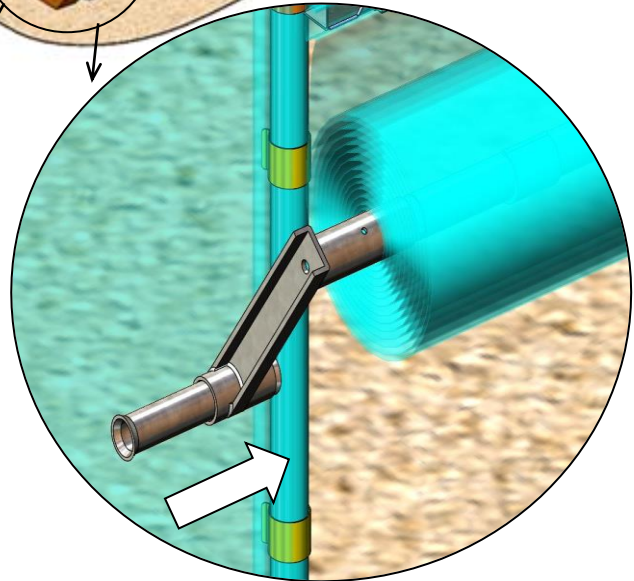
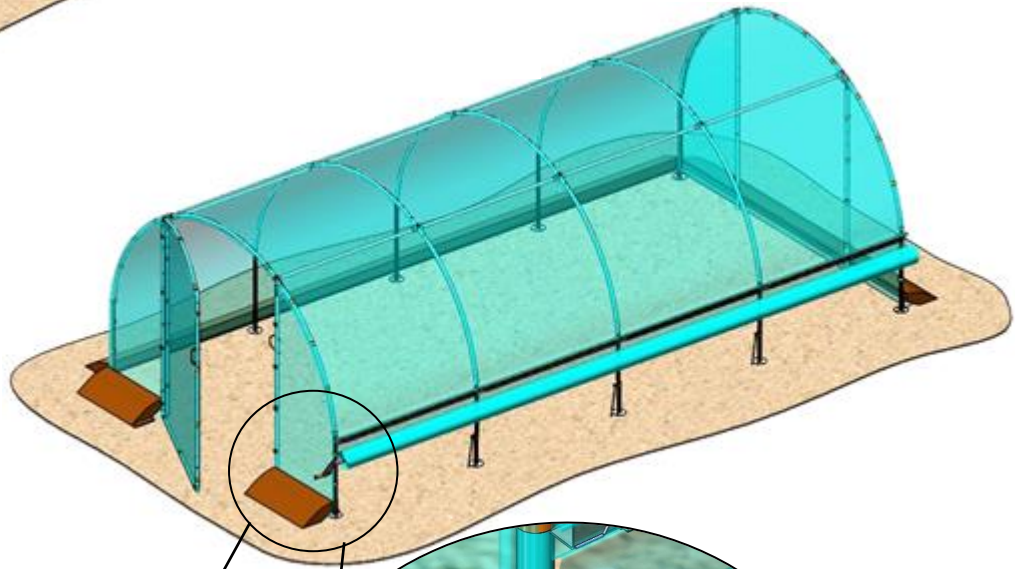
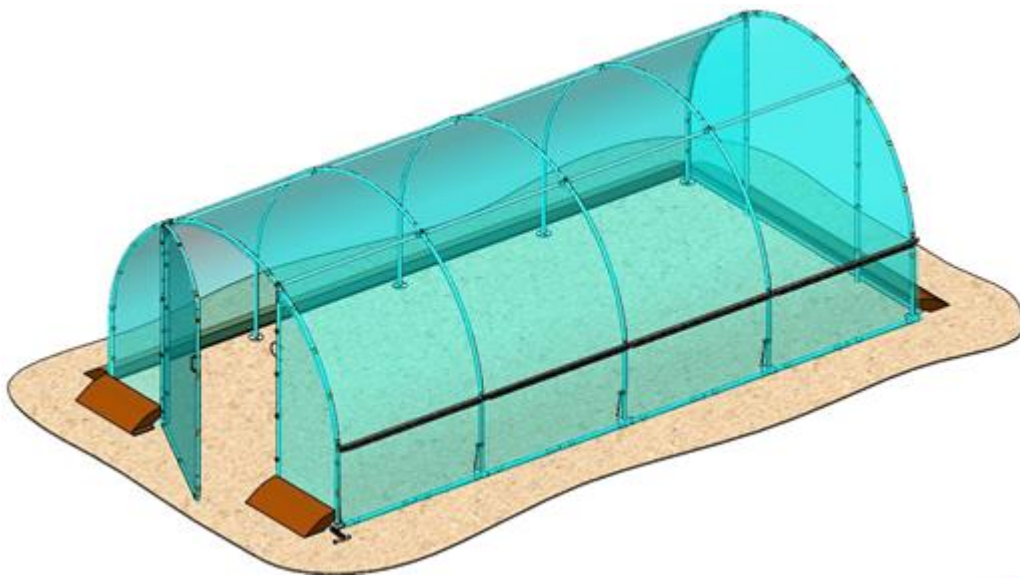

Blocage manivelle
Lock the crank handle
Zwengel blokkeren
Kurbel verriegeln

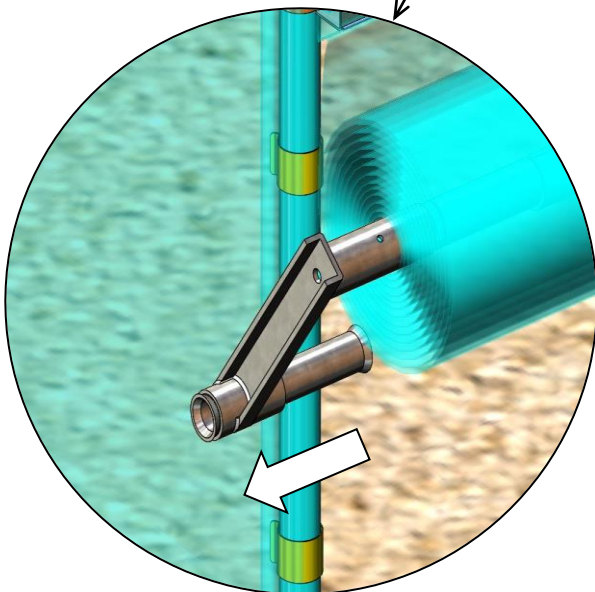

Déblocage manivelle
Release the crank handle
Zwengel deblokkeren
Kurbel entriegeln

C6751 · COLIS 1/1 POUR J10100 - AERATION LATERALE 6M		
P131137	CARRE 35 LG 1495 2 PER	4,00
P510151	CLIPS W LG1400	4,00
P510134	FIL CRENELE D2.3/D3mm 2m BLEU	3,00
P110542	RALLONGE D32 Lg 850 SERRE 2m	8,00
P730263	MANIVELLE AER LATE SDJ	1,00
P620845	AMARRE MONOBLOC 400x10 DISQUE 100x2,5	3,00
C6752	COLIS VISSERIE 1/1 POUR J10600	1,00
P710013	VIS TECK CR	0,00

C6752 · COLIS VISSERIE 1/1 POUR J10100		
P620134	BRIDE DIAMETRE 32	5,00
P410028	CAVALIER OMEGA D 32	3,00
P710013	VIS TECK CR	45,00
P710193	COLIS 6 BOULONS POELIER 8*50	1,00
P710007	VIS 8*70/70	5,00
P710014	ECROU FREIN H 8	5,00
P620255	CLIPS 3cm SANS BORD	16,00
P620724	FER A BETON DIA 8 HA LG 500	1,00
P743241	BOUCHON 35X35	2,00
P710214	EMBOUT VISSEUSE CARRE	1,00

**FICHE DE COMMUNICATION - COMPLAINT SHEET - KLACHTENFORMULIER -
REKLAMATIONSFORMULAR**

