

NOPAL 215417

2SL-1B1V1CL\TIPI

4,91x3,62x2,35 m

Réf : 215417



Descriptif :



Une très belle station de jeux, pour le plus grand plaisir des enfants !
Pattes de scellement fournies et à sceller dans un plot de béton.
Livrée en kit. À monter soi-même.

Ensemble complet livré avec :



Balancoire



Vis-à-vis



Balancelle



Toboggan

Schéma (en mm)



Tissu



Poteau à sceller au sol
- pattes de scellement fournies
- béton non fourni

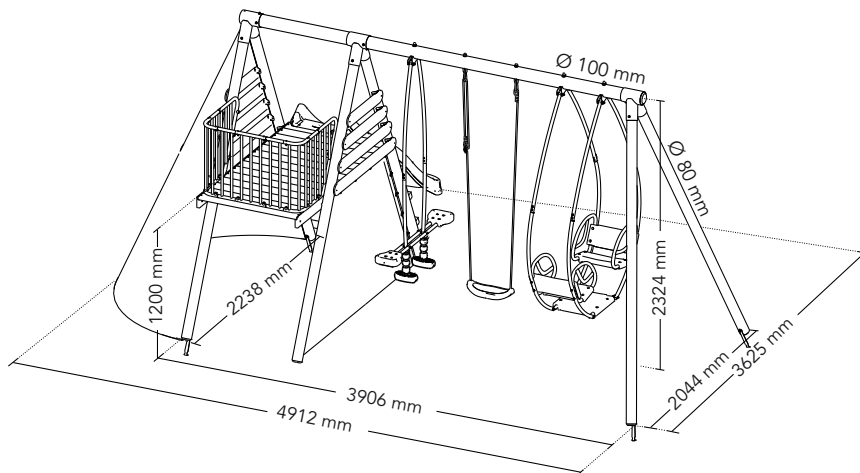

Norme sécurité
des jouets enfants.



Contre les Champignons
(Basidiomycètes, poutrière,
cubrique, fibreuse)



41 cm
233 cm
57,5 cm



16 cm
250 cm
34 cm



125 kg



Prix
TTC.

ATTENTION !



* sauf produits équipés
de siège bébé

