

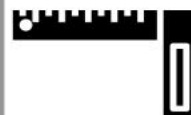

## SUNNY Xperience

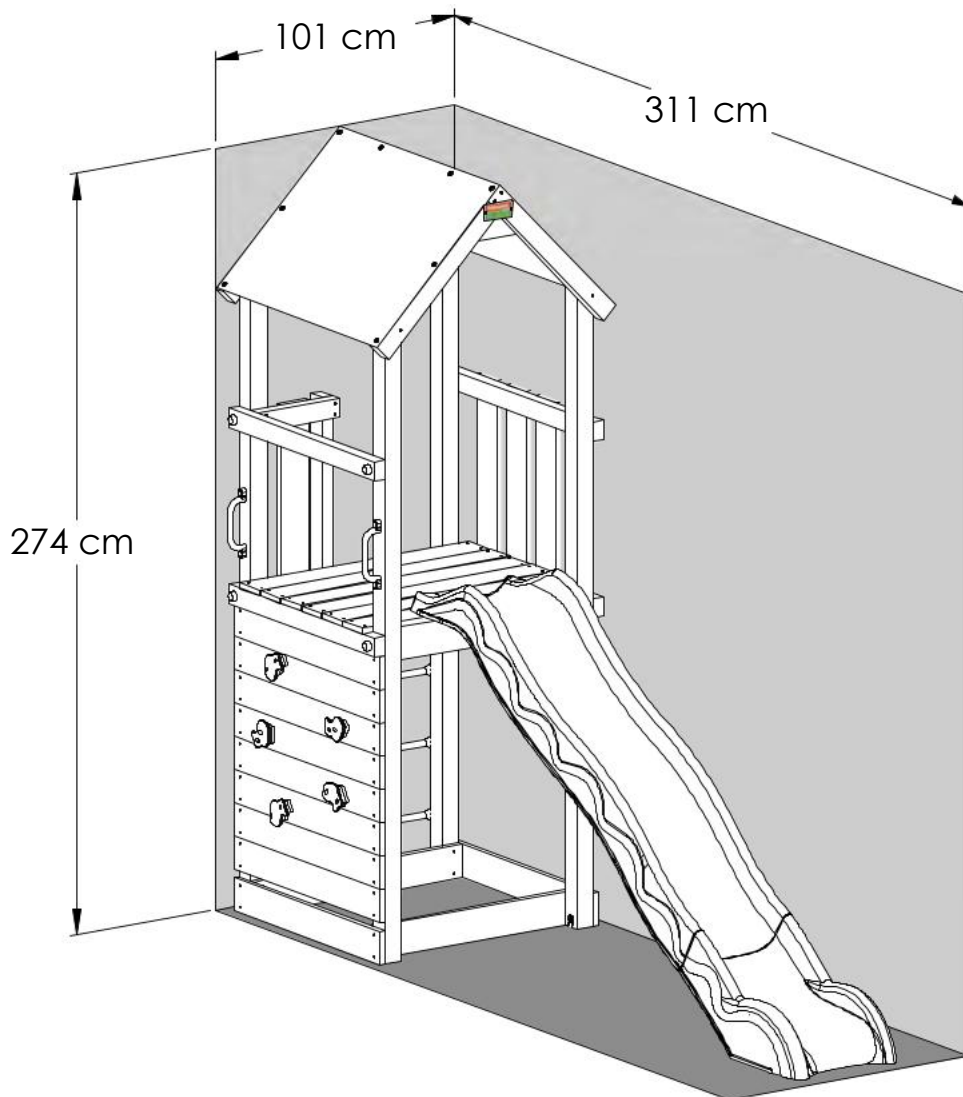

**ATTENTION - WARNING**  
**ACHTUNG - AVVERTENZA**  
**ADVERTENCIA - ATENÇÃO**  
**OSTRZEŻENIE - WAARSCHUWING**  
**OPOZORILA**



FR

Notice de Montage : Lire ces instructions avant utilisation, s'y conformer et les garder comme références.

Attention : Risque de chute. Réservé à un usage familial en extérieur. Sous les responsabilités et surveillance des parents. Ancre impératif avec le KIT SECUR'IN ou du béton.

EN

Assembly instructions: Read these instructions before use, ensure you comply with them, and keep them as a reference.

Warning : Risk of falling. This product is for family and outdoor use only. Under the responsibility and supervision of the parents. Structure must be anchored using KIT SECUR'IN or concrete.

DE

Montageanleitung: Bitte vor Gebrauch sorgfältig lesen, die darin enthaltenen Anweisungen befolgen und zum späteren Nachschlagen sicher aufbewahren.

Achtung : Sturzgefahr. Nur für den privathäuslichen Gebrauch im Freien vorgesehen. Unter der Verantwortung und Aufsicht der Eltern. Eine Verankerung mit dem SECUR'IN-Set oder mit Beton ist zwingend erforderlich.

NL

Montagetip: Lees deze instructies vóór gebruik, volg ze na en hou ze bij ter informatie.

Waarschuwing : Valgevaar. Voorbehouden aan outdoor gebruik in gezinsverband. Onder verantwoordelijkheid en toezicht van de ouders. Verplicht te verankeren met de SECUR'IN KIT of met beton.

IT

Istruzioni di montaggio: Leggere queste istruzioni prima dell'utilizzo, rispettarle e conservarle come promemoria.

Avvertenza : Rischio di caduta. Riservato a un uso familiare in ambienti esterni. Sotto la responsabilità e la supervisione dei genitori. Ancoraggio obbligatorio con il KIT SECUR'IN o del cemento.

ES

Instrucciones de montaje: Lea y siga las instrucciones antes de utilizar el producto. Consérvelas para futuras consultas.

Advertencia : Riesgo de caídas. Se trata de un producto diseñado para uso familiar y en el exterior. Bajo la responsabilidad y supervisión de los padres. Anclaje obligatorio con el KIT SECUR'IN o con hormigón.

PT

Instruções de Montagem: é favor ler atentamente as presentes instruções antes de utilizar o produto, respeitá-las e guardá-las como referência.

Atenção! Risco de cair. Produto reservado exclusivamente ao uso exterior e familiar. Sob a responsabilidade e supervisão dos pais. É obrigatório fixá-lo com o auxílio do KIT SECUR'IN ou com betão.

PL

**Instrukcja montażu:** przed użyciem zapoznać się z instrukcją, postępować według wskazówek i zachować do późniejszego wglądu.

**Ostrzeżenie :** Ryzyko upadku. Produkt przeznaczony do użytku domowego na zewnątrz. Pod odpowiedzialnością i nadzorem rodziców. Kotwienie obowiązkowe za pomocą zestawu KIT SECUR'IN lub w betonie.

SI

**Navodila za montažo:** Pred uporabo preberite ta navodila, jih upoštevajte in jih shranite za kasnejšo uporabo.

Opozorilo! Nevarnost padca. Samo za domačo uporabo. Noge izdelka morajo biti pritrjene s kompletom SECUR'IN ali zabetonirane.

# TRIGANO

41170 CORMENON - FRANCE

**FR -** Ce produit est un jouet d'activité suspendu au plafond. Il est conforme aux normes européennes NF EN 71, dans les conditions de montage et d'utilisation décrites dans cette notice.

### MONTAGE :

- Lisez cette notice avant le montage du produit et respectez les consignes.
- Conservez-la comme référence pour les opérations d'entretien ultérieures ou pour l'identification des composants par notre SAV.
- Le montage doit être effectué par des adultes, hors de portée des enfants pour éviter tous risques de blessure ou de touffement avec des petites pièces ou des éléments d'emballage.
- Ce produit est conçu avec des écrous anti-desserrage. Il est donc normal que le vissage soit ferme. Sauf indications contraires dans la notice, serrez jusque vous ne pouvez plus tourner ces écrous.
- Si votre produit comporte un toboggan, nous vous recommandons de ne pas l'orienter directement face au soleil.

### UTILISATION : Attention !

- Ce produit est conçu pour des enfants de 3 à 14 ans (50 kg max par enfant).
- Il ne convient pas aux enfants de moins de 36 mois (sauf siège bébé).
- Il est réservé à un usage familial et en extérieur.
- Face au risque de chute, l'utilisation du produit doit se faire sous la supervision d'un adulte.
- Les utilisateurs doivent porter des vêtements adaptés au jeu, sans cordelettes ni accessoires pouvant rester accrochés.
- Ils ne doivent pas boire, manger ou adopter tout autre comportement dangereux pendant l'utilisation du jouet d'activité.

### MAINTENANCE :

- Avant la mise en service, au début de chaque saison, ainsi qu'à intervalles réguliers en cours de saison.
- Vérifiez l'absence de ventuels défauts de la structure.
- Si des tâches de rouille apparaissent sur les éléments métalliques peints, traitez-les avec un produit adapté.
- Vérifiez les sièges des balançoires, les chaînes, les cordes et autres dispositifs de fixation à la recherche de signes de dégradation.
- Inspectez toutes les vis, les écrous et les systèmes de fixation des agrès. Resserrez-les si nécessaire. Si les systèmes de fixation des agrès grincent, utilisez un lubrifiant aérosol à base de silicone. En cas de doute ou d'apparition de rouille, remplacez-les par des composants identiques.
- Remplacez les caches des vis et des écrous en cas de perte ou à la moindre dégradation.
- Vérifiez l'état des agrès et remplacez-les aux premiers signes d'usure par des agrès de même nature et de même conception que ceux d'origine.
- Pour une meilleure durée de vie des agrès, du toboggan et des autres pièces plastiques, mettez-les à l'abri l'hiver ou en cas de non-utilisation prolongée.
- Les tissus, bâches et autres composants plastiques doivent être nettoyés à l'aide d'une éponge humide. N'utilisez pas de produits agressifs.

**À défaut de procéder à toutes ces vérifications et remises en état éventuelles, le produit peut se renverser ou constituer un danger.**

### INFORMATIONS POUR LES PRODUITS CONTENANT DU BOIS :

- Le bois est un matériau qui réagit naturellement aux variations de température et d'humidité. Il se contracte et se dilate, ce qui peut entraîner l'apparition de fentes. Mais ces fentes peuvent sembler impressionnantes, elles ne nuisent en rien à la solidité et à la durabilité de votre produit. C'est tout simplement le bois qui se contracte et se dilate.
- Le bois étant traité par imprégnation autoclave, aucun traitement supplémentaire contre les intempéries et le pourrissement n'est nécessaire. N'utilisez pas de vernis ou de peinture qui rendrait les surfaces glissantes.

**SAV :** Toute intervention ou modification du produit, qui sortirait du cadre de cette notice, entraînera la perte de la garantie. Seules les pièces détachées fournies par TRIGANO doivent être utilisées. Pour toute demande de SAV, connectez-vous sur [www.triganojardin.com/sav/](http://www.triganojardin.com/sav/)

**Nous vous souhaitons, ainsi qu'à vos enfants, de passer d'agréables moments avec votre nouveau produit TRIGANO.**

**EN -** This product is an activity toy that complies with the NF EN 71 European standards in how it is to be assembled and used, as detailed in these instructions.

### ASSEMBLY:

- These instructions must be read prior to assembling the product, and complied with.
  - Keep them at hand for any maintenance or upkeep to be conducted at a later date, or for assisting our after-sales team in identifying parts.
  - Assembly must be carried out by adults, out of reach of children to avoid any risk of injury or suffocation by small parts or packaging.
  - This product is designed with anti-loosening nuts. They should therefore be tight. Unless otherwise specified in the instructions, tighten until there is no space between the parts to assemble, and follow up with an extra half-turn.
  - The product must imperatively be anchored.
  - This must be carried out on a level surface at least two metres away from any object, structure, or obstacle (such as a wall, barrier, tree branch, laundry line, or electric cable).
  - Do not set up the product over concrete, asphalt, or any other type of hard-surfaced ground. Choose soft ground (such as grass, sand, or protective mats).
  - If your product includes a slide, we recommend not positioning it in direct sunlight.
- USE: Warning!**
- This product is designed for children aged 3 to 14 (50 kilos max. per child).
  - Not suitable for children under 3 years (except baby seat).
  - This product is for family and outdoor use only.
  - Due to the risk of falling, this activity toy must only be used under adult supervision.
  - Users must wear appropriate play clothing free from any dangling ties or accessories that might catch.
  - They must not eat, drink, or engage in any other form of dangerous behaviour while using the activity toy.

**MAINTENANCE:** At the beginning of each season, and at regular intervals during the season.

- Check that the structure is free from any potential defects.
- Check swing seats, chains, cords and other fasteners for signs of wear.
- If rust appears on the painted metallic parts, treat them using a suitable product.
- Inspect all the apparatuses (screws, nuts, fastening/fixing systems). Tighten them if necessary. If the apparatuses (fastening/fixing systems) creak or squeak, apply a silicone spray lubricant. If in doubt, or in the event of rusting, replace parts with identical parts.
- Replace screw and nut heads in the event they are lost or show the slightest sign of wear.
- Check up on the apparatuses and replace them at the first sign of wear by apparatuses of the same kind and design as the original apparatuses.
- To improve the lifespan of the apparatuses, slide, and other plastic parts, keep them in a dry place over winter or when not in use for an extended period.
- Fabric and tarp components and other plastic parts must be cleaned with a damp sponge. Do not use harsh products.

**If these checks and maintenance jobs are not performed, the structure could fall over or become dangerous.**

### INFORMATION FOR PRODUCTS THAT CONTAIN WOOD:

- Wood is a material that reacts naturally to variations in temperature and humidity. When wood dries, it shrinks unevenly, which can cause splitting. Although this may look striking, it does not impact on your product's lifespan or sturdiness, which is why this isn't covered by the warranty. Simply check for splinters and sand them down where needed.
- Because the wood has been treated via autoclave impregnation, no further weather/rotting treatment is required. Do not varnish or paint in such a way as to make the surfaces slippery.

**SPARE PARTS:** Any intervention or changes made to the product beyond the scope of these instructions shall not be covered by the warranty. Only TRIGANO replacement parts should be used. For any after-sales questions you might have, log on to [www.triganojardin.com/sav/](http://www.triganojardin.com/sav/)

**We wish you and your children pleasant playtimes with your new TRIGANO product.**

**DE -** Dieses Produkt ist ein Spielgerät, das den Anforderungen der europäischen Norm NF EN 71 entspricht, sofern Montage und Nutzung den in dieser Anleitung aufgeführten Bedingungen entsprechen.

### MONTAGE:

- Lesen Sie diese Anleitung vor dem Zusammenbau des Produkts und befolgen Sie die Anweisungen.
- Bewahren Sie sie als Referenz für spätere Wartungsarbeiten oder zur Identifizierung von Komponenten durch unseren Kundendienst auf.
- Die Montage sollte von Erwachsenen außerhalb der Reichweite von Kindern durchgeführt werden, um Verletzungen oder Erstickengefahr durch Kleinteile oder Verpackungsmaterial zu vermeiden.
- Dieses Produkt wurde mit Sicherungsmuttern entworfen. Es ist daher normal, dass beim Eindrehen der Schrauben ein wenig Kraftaufwand nötig ist. Wenn in der Anleitung nichts anderes angegeben ist, ziehen Sie die Schraube fest, bis zwischen den zu verbindenden Teilen kein Spalt mehr vorhanden ist. Drehen Sie die Schraube dann noch einmal um eine halbe Umdrehung weiter.
- Die Bodenverankerung des Produkts ist zwingend erforderlich. Sie sollte auf einer ebenen Fläche und mit einem Abstand von mindestens 2 m zu anderen Objekten, Bauten oder Hindernissen (z. B. Mauern, Zäune, Äste, Wäscheleinen oder Stromkabel) erfolgen.
- Installieren Sie das Produkt nicht auf Beton, Asphalt oder anderen Hartbelägen. Bevorzugen Sie einen weichen Untergrund (z. B. Gras, Sand oder Fallschutzplatten).
- Wenn Ihr Produkt eine Rutsche umfasst, empfehlen wir Ihnen, diese nicht frontal zur Sonne hin auszurichten.

### NUTZUNG: Achtung !

- Dieses Produkt ist für Kinder von 3 bis 14 Jahre geeignet (max. 50 kg pro Kind).
- Es ist nicht für Kinder unter 36 Monaten geeignet (außer Kinderstuhl).
- Es ist nur für den privathäuslichen Gebrauch im Freien vorgesehen.
- Angesichts der Sturzgefahr sollte das Spielgerät nur unter Aufsicht eines Erwachsenen verwendet werden.
- Bei der Nutzung muss Kleidung getragen werden, die zum Spielen geeignet ist, ohne Bänder oder Accessoires, die hängen bleiben können.
- Während der Nutzung des Spielgeräts darf nicht getrunken, gegessen oder ein anderes gefährliches Verhalten an den Tag gelegt werden.

**WARTUNG:** Zu Beginn jeder Saison sowie regelmäßig während der Gebrauchssaison zu befolgen.

- Überprüfen Sie die Struktur auf mögliche Mängel.
  - Überprüfen Sie die Schaukelsitze, Ketten, Seile und anderen Befestigungssysteme auf Beschädigungen.
  - Wenn Rostflecken auf lackierten Metallteilen auftreten, behandeln Sie diese mit einem geeigneten Mittel.
  - Überprüfen Sie alle Schrauben, Muttern und Befestigungssysteme der Turngeräte. Ziehen Sie sie gegebenenfalls nach. Wenn die Befestigungssysteme der Turngeräte quietschen, verwenden Sie ein Schmiermittel auf Silikonbasis zum Sprühen. Im Zweifelsfall oder bei Auftreten von Rost sollten Sie die Befestigungssysteme durch identische Komponenten ersetzen.
  - Ersetzen Sie die Abdeckungen von Schrauben und Muttern, wenn sie verloren gehen oder bei der geringsten Beschädigung.
  - Überprüfen Sie den Zustand der Turngeräte und ersetzen Sie diese bei ersten Anzeichen von Verschleiß durch Geräte derselben Art und Ausführung.
  - Um die Lebensdauer der Turngeräte, der Rutsche und anderer Kunststoffteile zu erhöhen, sollten Sie sie im Winter oder bei längerer Nichtbenutzung an einem geschützten Ort lagern.
  - Textil, Planen und andere Kunststoffkomponenten sollten mit einem feuchten Schwamm gereinigt werden. Verwenden Sie keine aggressiven Reinigungsmittel.
- Sollten Sie es versäumen, all die vorgenannten Überprüfungen und Instandhaltungsmaßnahmen durchzuführen, riskieren Sie, dass das Gerät seine Standfestigkeit verliert und zur Gefahrenquelle wird.**

### INFORMATIONEN FÜR PRODUKTE, DIE HOLZ ENTHALTEN:

- Holz ist ein Material, das auf natürliche Weise auf Temperatur- und Feuchtigkeitsschwankungen reagiert. Wenn es trocknet, zieht es sich unregelmäßig zusammen, wodurch Risse entstehen. Auch wenn diese beeindruckend aussehen mögen, beeinträchtigen sie in keiner Weise die Belastbarkeit und Haltbarkeit Ihres Produkts. Daher fallen sie nicht unter die Garantie. Kontrollieren Sie einfach, ob Splitter vorhanden sind, und schleifen Sie die Holzbestandteile gegebenenfalls ab.
- Da das Holz kesseldruckimprägniert ist, ist keine zusätzliche Behandlung gegen Witterung und Faulen erforderlich. Verwenden Sie keine Lacke oder Farben, die die Oberflächen rutschig machen.

**ERSATZTEILE:** Jegliche Eingriffe oder Veränderungen am Produkt, die über den Rahmen dieser Anleitung hinausgehen, führen zum Garantieverlust. Es dürfen ausschließlich Ersatzteile von TRIGANO verwendet werden. Für Kundendienstanfragen loggen Sie sich ein unter [www.triganojardin.com/sav/](http://www.triganojardin.com/sav/)

**Wir wünschen Ihnen und Ihren Kindern viel Spaß mit Ihrem neuen TRIGANO Produkt.**

**IT -** Questo prodotto è un giocattolo per attività che soddisfa i requisiti delle norme europee NF EN 71, nelle condizioni di montaggio e utilizzo descritte in questo libretto.

### MONTAGGIO:

- Leggere questo libretto prima del montaggio del prodotto e seguire le istruzioni.
- Conservarlo come riferimento per le successive operazioni di manutenzione o l'identificazione dei vari elementi del prodotto da parte del nostro Servizio Post-Vendita.
- Il montaggio deve essere effettuato da adulti, fuori dalla portata dei bambini, per evitare qualsiasi rischio di lesioni o soffocamento causato da piccoli pezzi o elementi di imballaggio.
- Questo prodotto è stato progettato con dadi autobloccanti. È quindi normale che il avvvitamento richieda una certa forza. Salvo indicazioni contrarie espresse nel libretto, stringere fino ad annullare lo spazio tra i pezzi da assemblare ed effettuare poi un ulteriore mezzo giro.
- L'ancoraggio del prodotto è obbligatorio.
- Deve essere eseguito su una superficie piana, a una distanza minima di 2 metri da qualsiasi altro oggetto, struttura od ostacolo (es.: muro, barriera, ramo d'albero, filo per biancheria o cavo elettrico).
- Non installare il prodotto su calcestruzzo, asfalto o altri rivestimenti duri. Preferire un terreno soffice (es.: erba, sabbia o lastre ammortizzanti).
- Se il prodotto comporta uno scivolo, consigliamo di non orientarlo direttamente di fronte al sole.

### UTILIZZO: Avvertenza!

- Questo prodotto è stato progettato per bambini dai 3 ai 14 anni (peso massimo di 50 kg per bambino).
- Non adatto ai bambini di un'età inferiore ai 36 mesi (eccetto seggiolino per bambini).
- Riservato a un uso in famiglia e all'aria aperta.
- Visto il rischio di caduta, l'utilizzo del giocattolo per attività deve avvenire sotto la supervisione di un adulto.
- Gli utilizzatori devono indossare indumenti adatti al gioco, senza cordicelle o accessori che potrebbero impigliarsi.
- Non devono bere, mangiare o comportarsi in modo pericoloso durante l'uso del giocattolo.

**MANUTENZIONE:** All'inizio di ogni stagione e ad intervalli regolari nel corso della stagione.

- Verificare l'assenza di eventuali difetti strutturali.
- Verificare le sedute delle altalene, le catene, le corde e gli altri dispositivi di fissaggio per escludere eventuali segni di danneggiamento.
- Se dovessero comparire macchie di ruggine sugli elementi metallici verniciati, trattarle con un prodotto adeguato.
- Ispezionare tutte le viti, i dadi e i sistemi di fissaggio degli attrezzi. Se del caso, stringerli. Se i sistemi di fissaggio degli attrezzi cingolassero, usare un lubrificante aerosol a base di silicone. In caso di dubbio o comparsa di ruggine, sostituirli con pezzi identici.
- Sostituire le protezioni delle viti e dei dadi in caso di smarrimento o tracce di deterioramento.
- Controllare lo stato degli attrezzi e sostituirli ai primi segni di usura con attrezzi dello stesso tipo di quelli originali.
- Per una migliore durata degli attrezzi, dello scivolo e degli altri pezzi di plastica, metterli al riparo in inverno o in caso di non utilizzo prolungato.
- Tessuti, teli e altri componenti in plastica devono essere puliti con una spugna umida. Non usare prodotti aggressivi.

**Nel caso in cui questi controlli e restauri non vengano effettuati, il gioco può rovesciarsi o costituire un pericolo.**

### INFORMAZIONI PER I PRODOTTI CONTENENTI LEGNO:

- Il legno è un materiale che risponde naturalmente alle variazioni di temperatura e umidità. Quando si asciuga, si ritrae in modo irregolare, provocando la comparsa di fessure. Anche se possono sembrare impressionanti, le suddette fessure non pregiudicano la solidità e la durata di vita del prodotto. Per questo motivo, non rientrano nell'ambito della garanzia. È sufficiente verificare l'eventuale presenza di scheghe e levigarle ove necessario.
- Poiché il legno è trattato mediante impregnazione in autoclave, non è necessario alcun trattamento supplementare contro le intemperie e la decomposizione. Non utilizzare vernici o smalti che potrebbero rendere le superfici scivolose.

**SERVIZIO POST VENDITA:** Qualsiasi intervento o modifica del prodotto che non rientri nell'ambito di questo libretto comporterà la decadenza della garanzia. Devono essere utilizzati solo pezzi di ricambio TRIGANO. Per qualsiasi richiesta al Servizio Post-Vendita, connettersi a [www.triganojardin.com/sav/](http://www.triganojardin.com/sav/)

**Auguriamo a voi e ai vostri bambini di trascorrere piacevoli momenti con il vostro nuovo prodotto TRIGANO.**

**ES -** Este producto es un juguete de actividad que cumple los requisitos de las normas europeas NF EN 71, en las condiciones de montaje y utilización detalladas en este documento.

### MONTAGE:

- Lea este manual antes de montar el producto y siga las instrucciones.
- Consérvelo como referencia para las operaciones de mantenimiento posteriores o para que nuestro servicio posventa pueda identificar los componentes.
- El montaje deben realizarlo personas adultas, fuera del alcance de los niños, para evitar riesgos de heridas o de asfixia con piezas pequeñas o elementos del embalaje.
- Este producto está diseñado con tornillos no deberían aflojarse. Salvo indicación de lo contrario en las instrucciones, se deben apretar las piezas hasta que no queda ningún espacio entre ellas y, una vez hecho esto, efectuar media vuelta más.
- El anclaje del producto es obligatorio.
- Debe realizarse sobre una superficie nivelada, a 2 m como mínimo de cualquier objeto, estructura u obstáculo (por ejemplo: muro, barrera, rama de árbol, cuerda para tender la ropa o cable eléctrico).
- No instale el producto sobre hormigón, asfalto o cualquier otro tipo de revestimiento duro. De prioridad a un suelo mullido (por ejemplo: hierba, arena o losas amortiguadoras).
- Si el producto incluye un tobogán, le recomendamos que no lo oriente directamente hacia el sol.

### UTILIZACIÓN: ¡Advertencia!





- Este producto se ha diseñado para niños de 3 a 14 años (50 kg max. por niño).
- No recomendado para menores de 36 meses (excepto asiento de bebé).
- Se trata de un producto diseñado para uso familiar y en el exterior. Ante el riesgo de caída, el uso del juguete de actividad debe hacerse bajo la supervisión de un adulto.

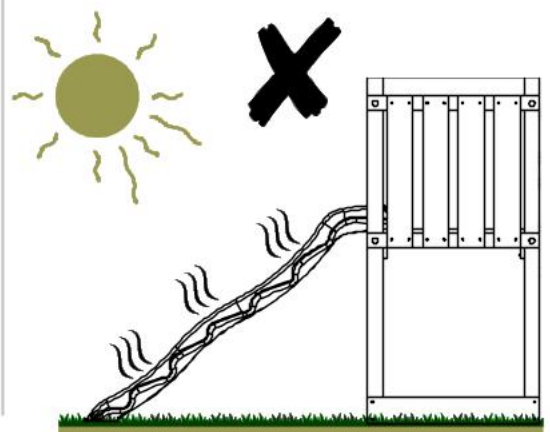
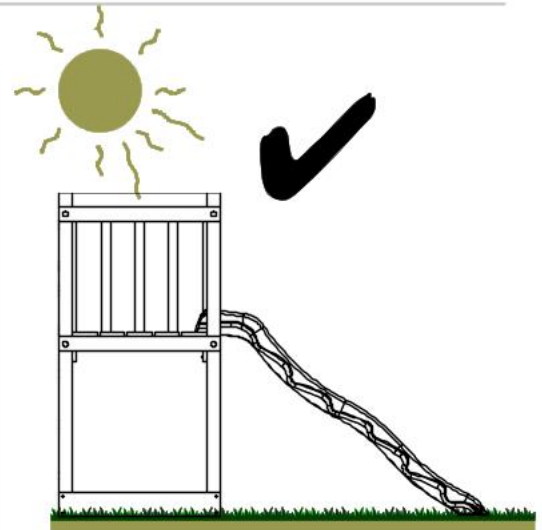
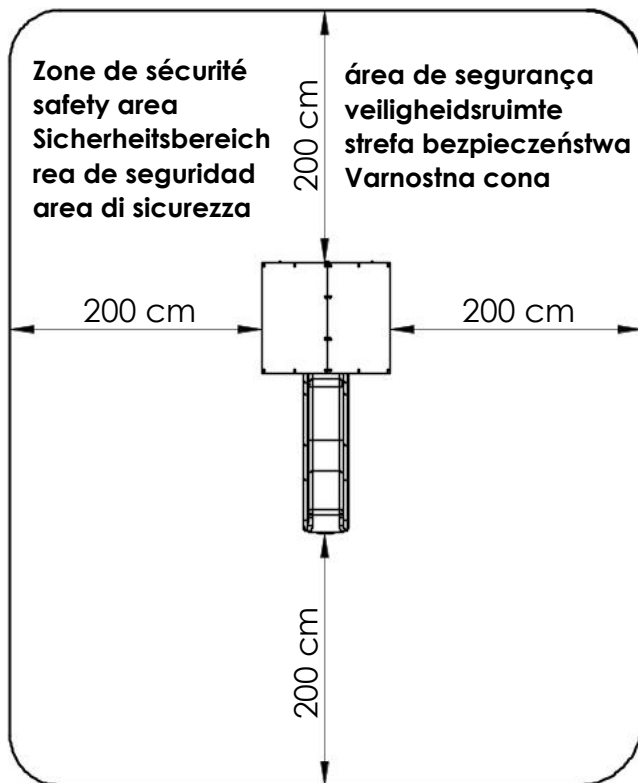
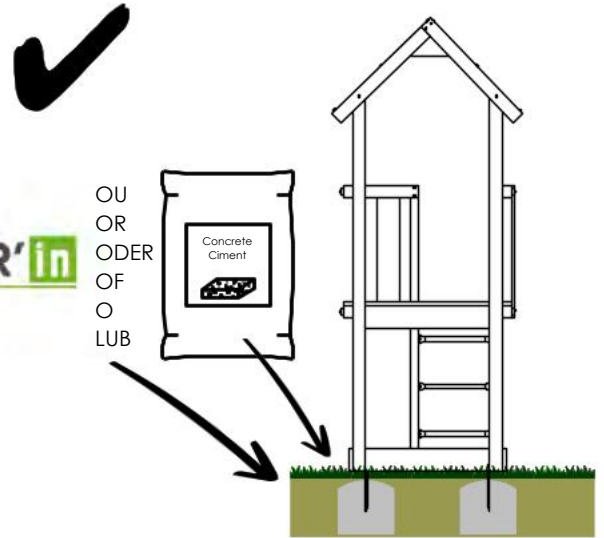
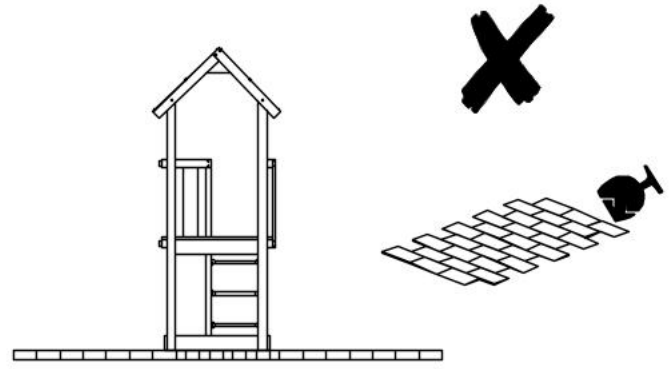
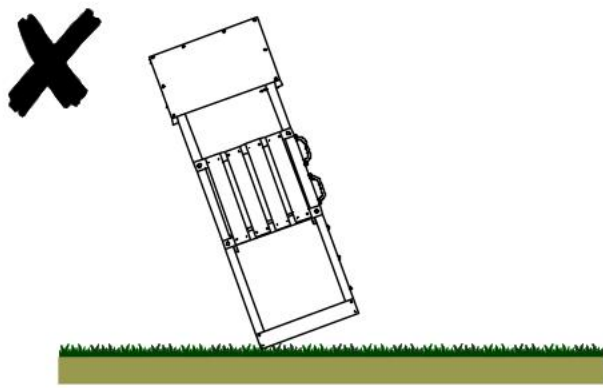
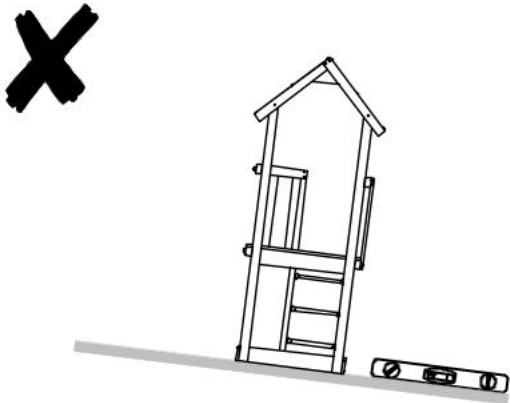

# WARNINGS

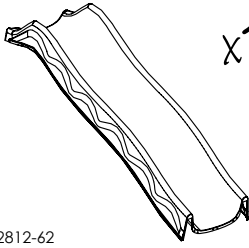
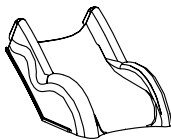
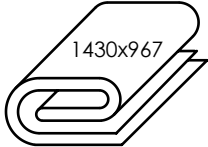
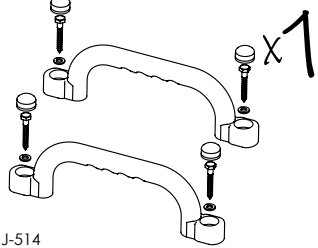

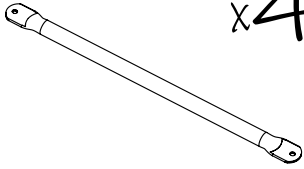
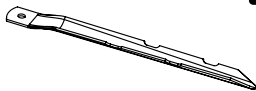
# SUNNY Xperience 1/3

 J-122812-62 x1	 J-122814-62 x1	 J-122915 x1	 J-514 x1
 J-512 x1	 J-15036826 x4	 J-152810 x2	 J-124966 x1

## Tools / Outils

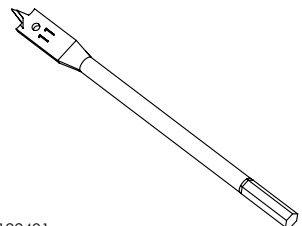
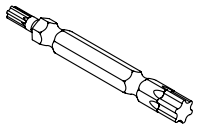
 J-122401	 J-122401
-------------------------------------------------------------------------------------------------	-------------------------------------------------------------------------------------------------

# SUNNY Xperience 2/3

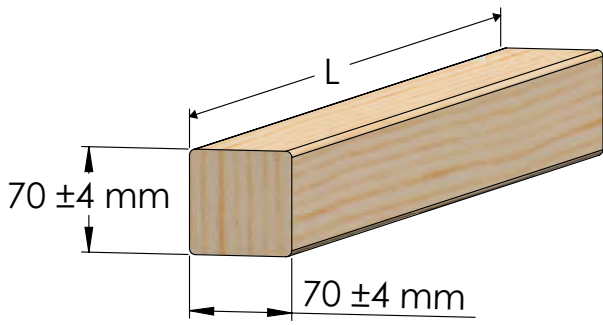

L	2300	x 4	J-120012
---	------	-----	----------

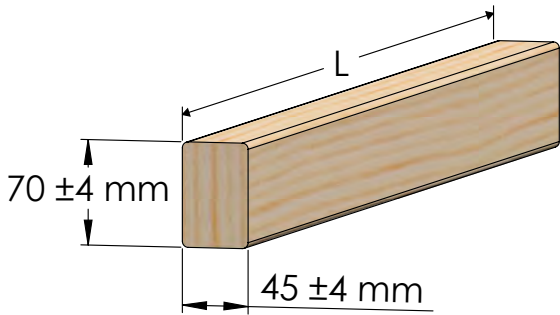

L	1815	x 1	J-125609
	885	x 5	J-125611
	705	x 3	J-125606
	657	x 2	J-125607
	350	x 1	J-125608

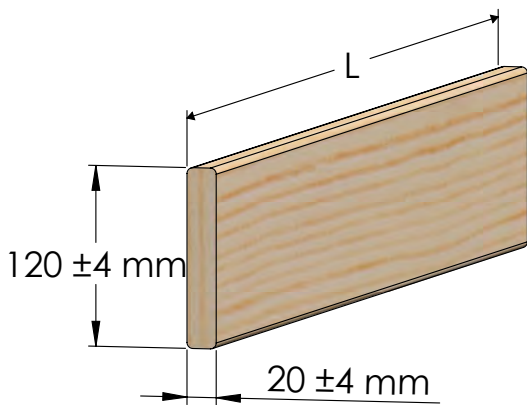

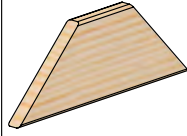
L	975	x 6	J-125610
	885	x 14	J-125601
	700	x 5	J-125603
	400	x 2	J-125604
			

# SUNNY Xperience 3/3

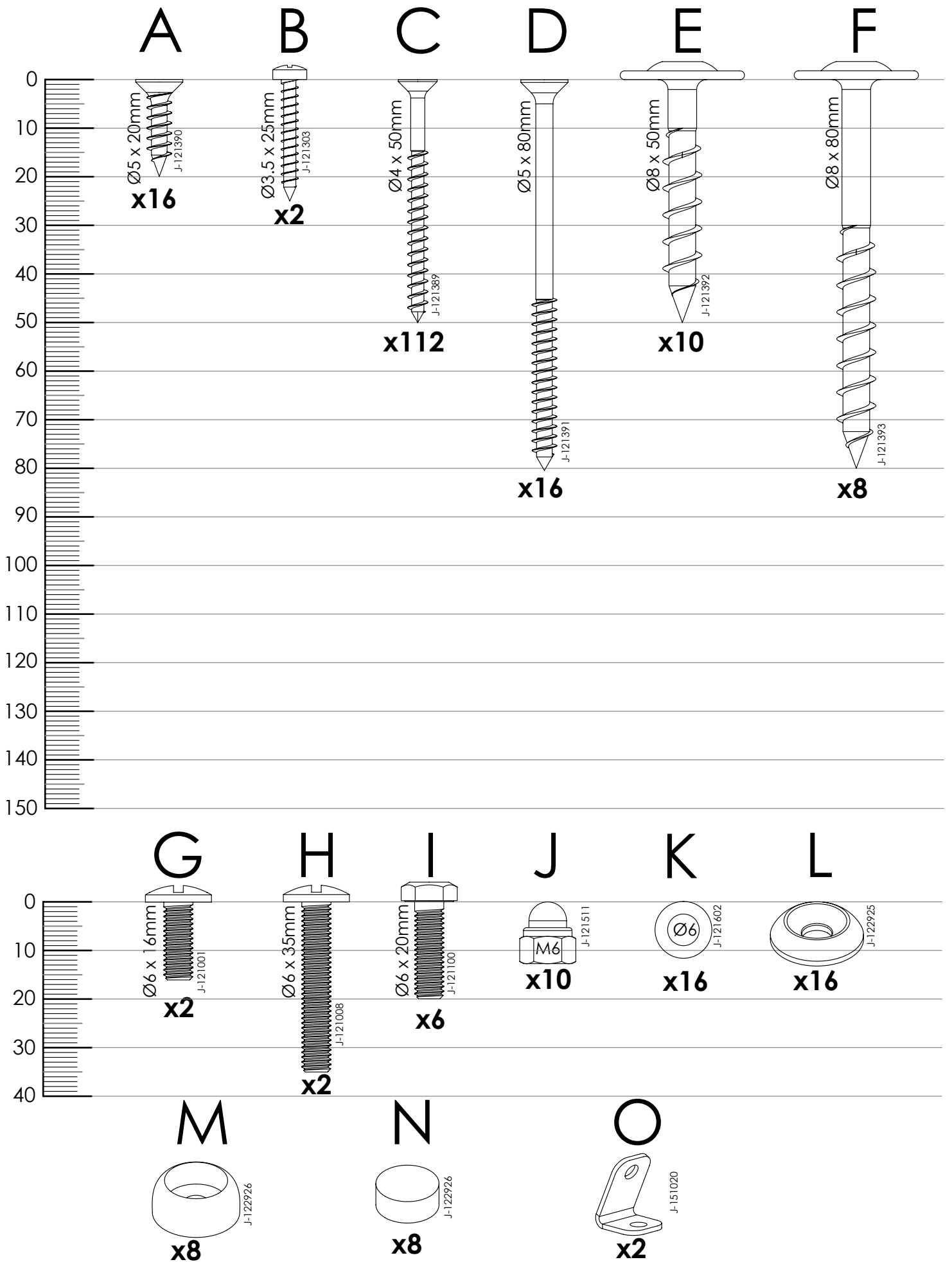

**1**

Ø4 x 50mm  
Cx8

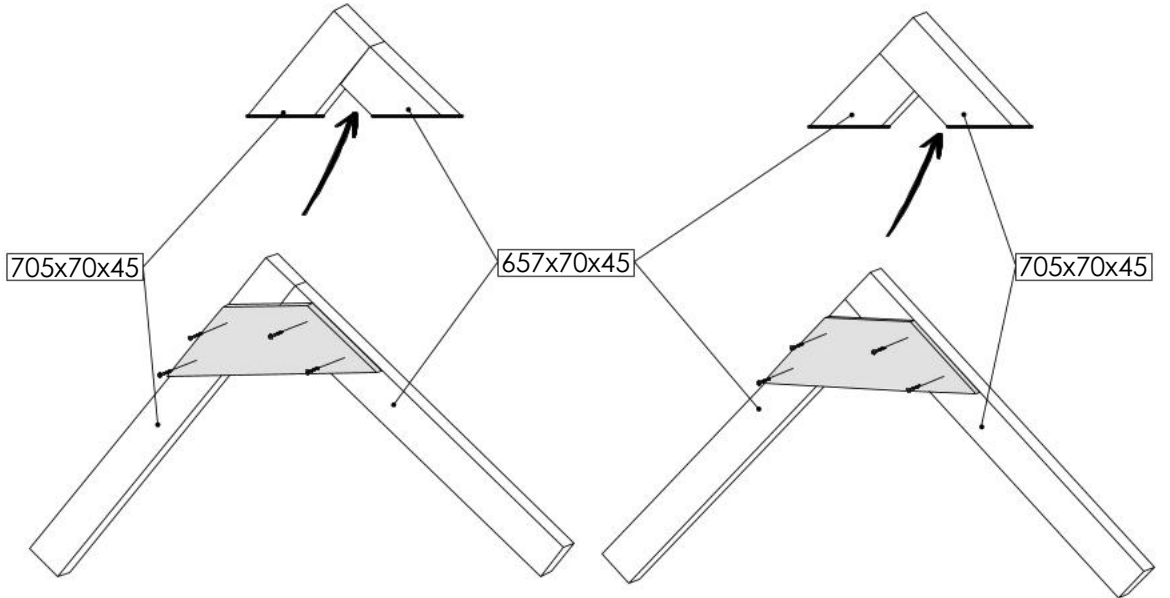

**2**

Ø4 x 50mm Cx8  
Fx8  
Ø8 x 80mm  
Mx8  
Ø5

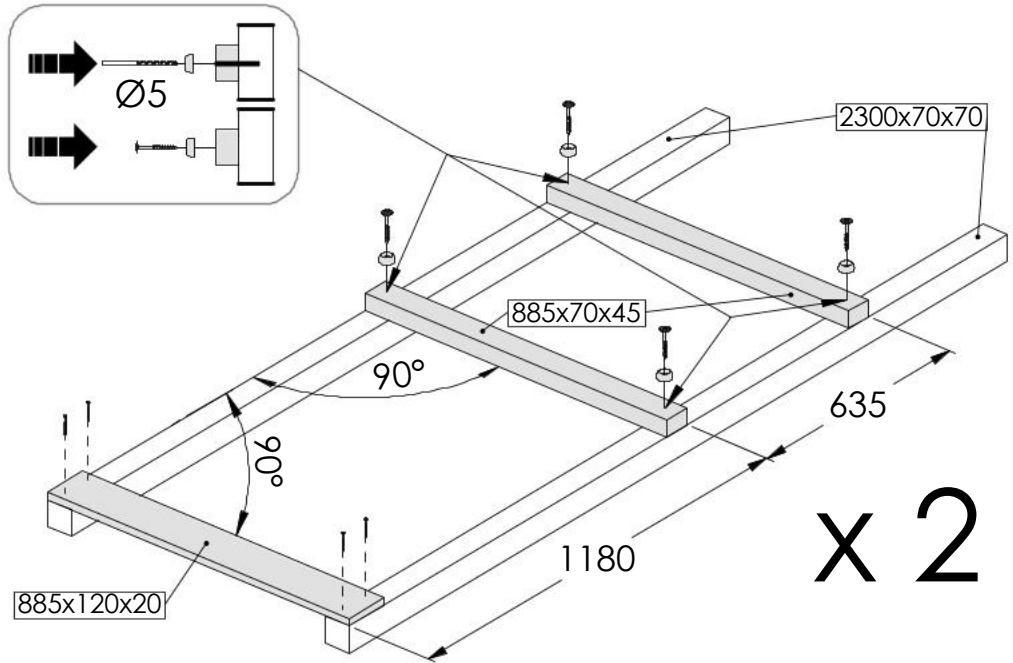

**3**

Ø4 x 50mm  
Cx8

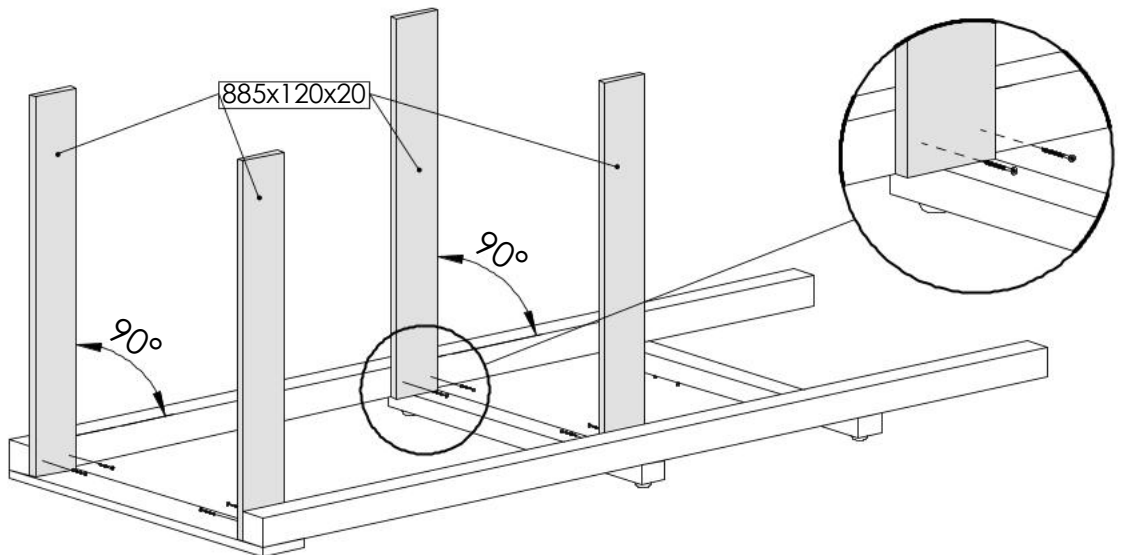

4



Cx8

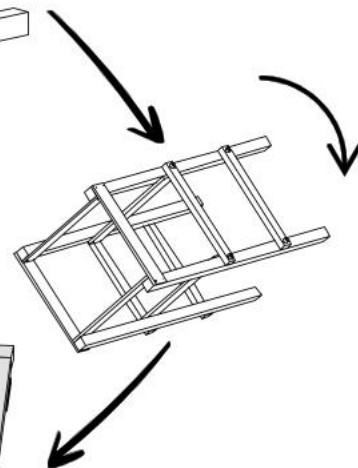
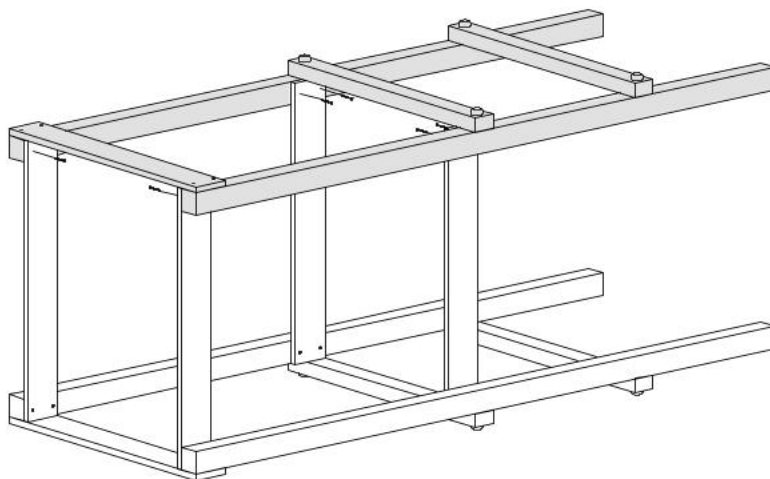

5

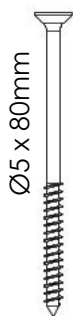

Dx2

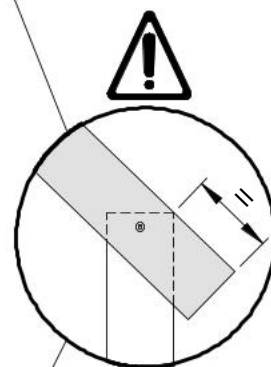
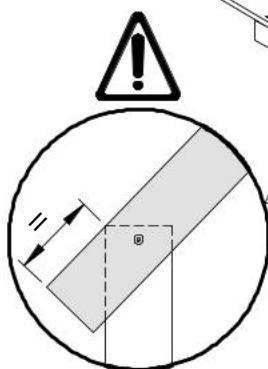
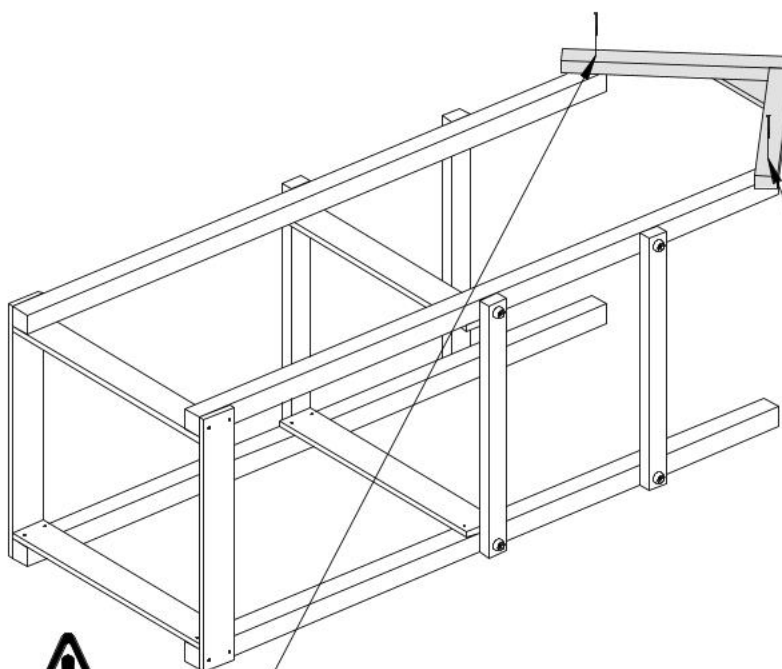

6

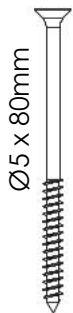

Dx2

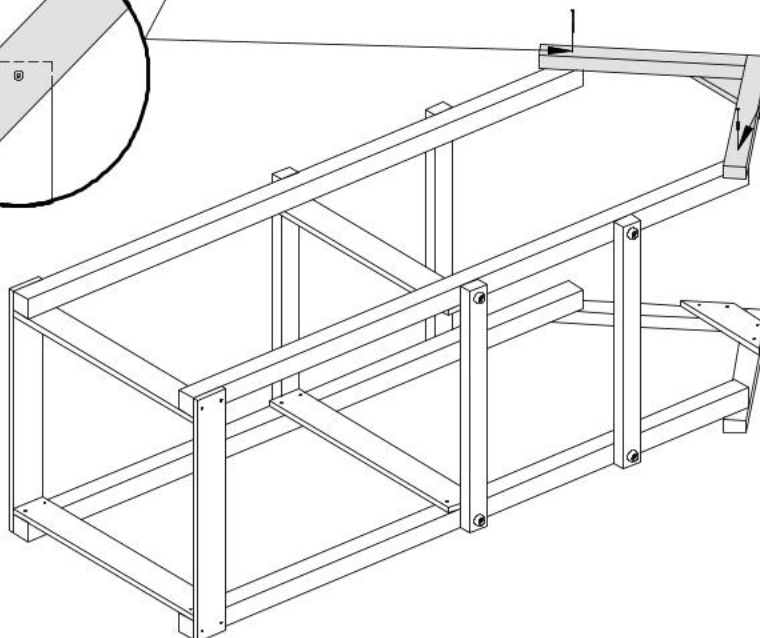

7



Dx4

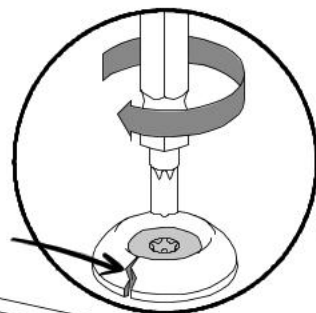
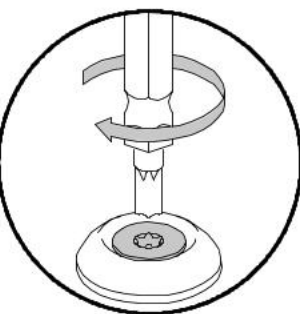
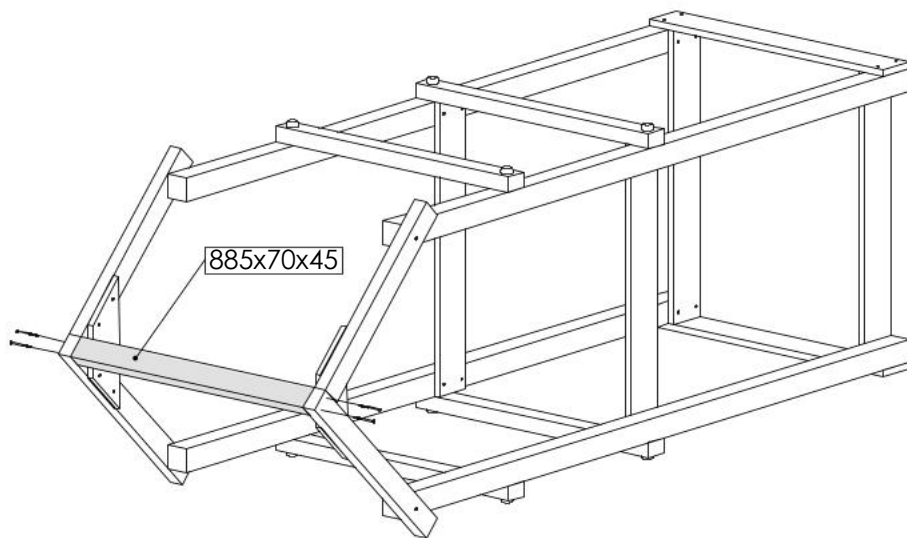

8

Ø4 x 20mm



Ax16



Lx16

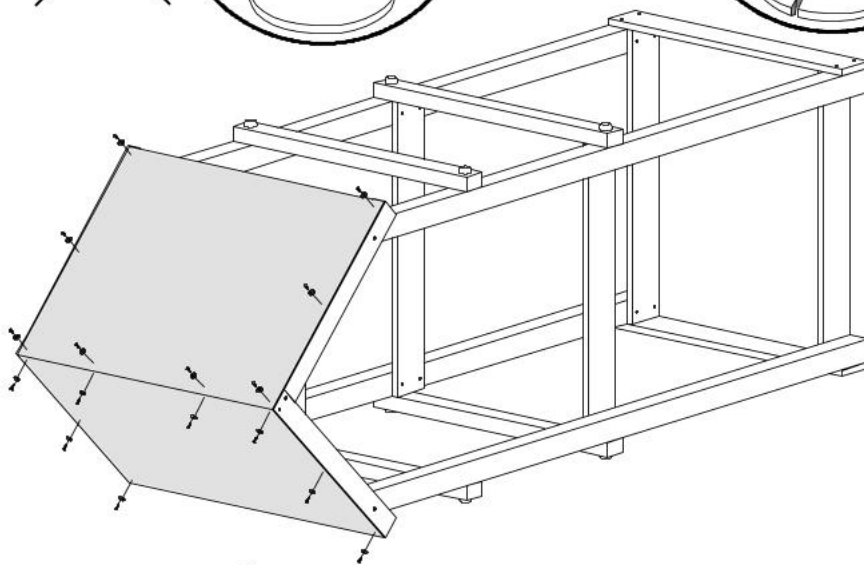

9

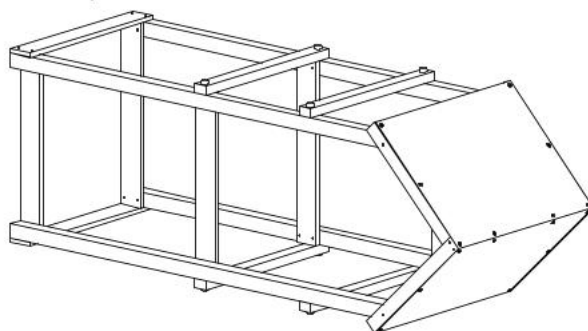
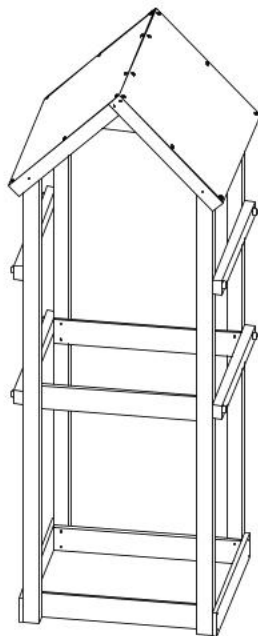

10



Dx4

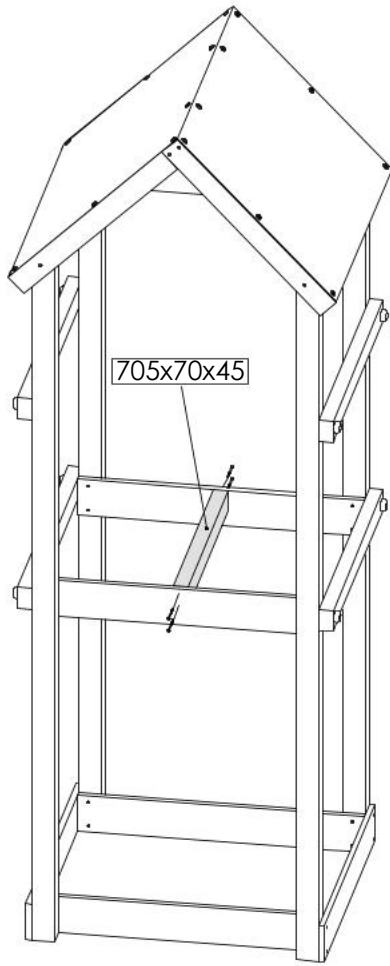

705x70x45

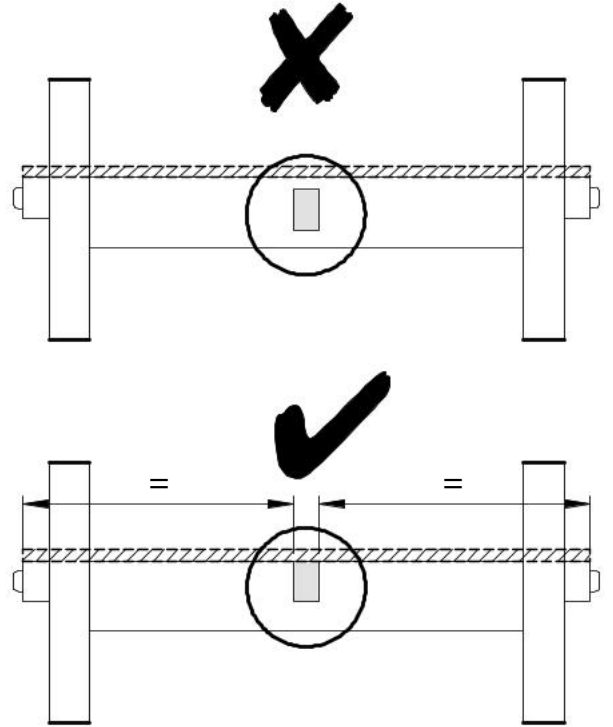

11



Cx4

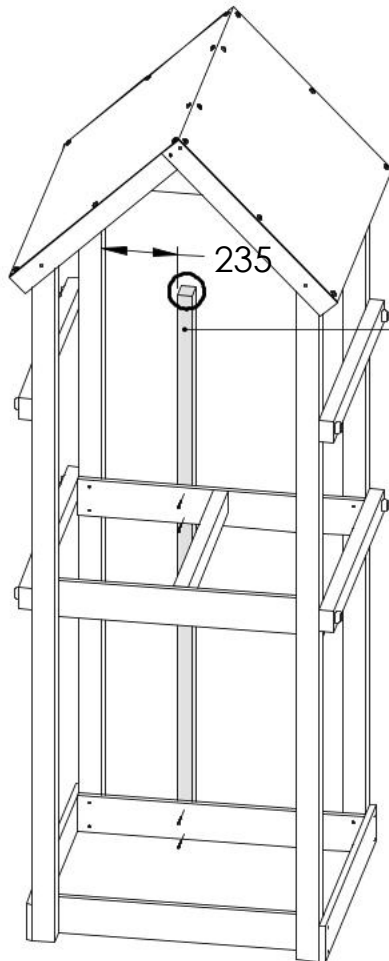

235

1815x70x45

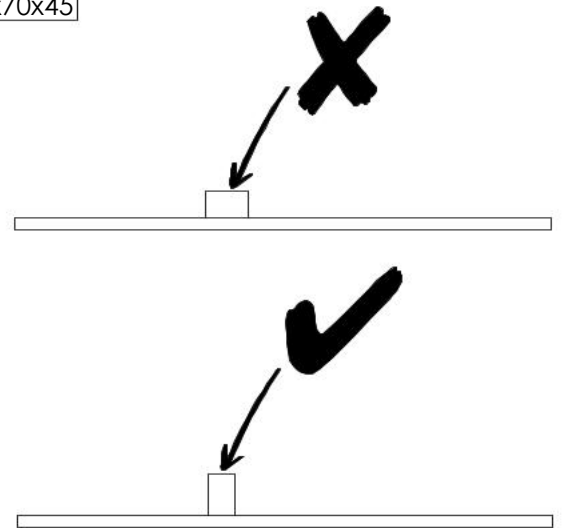

12



Dx4

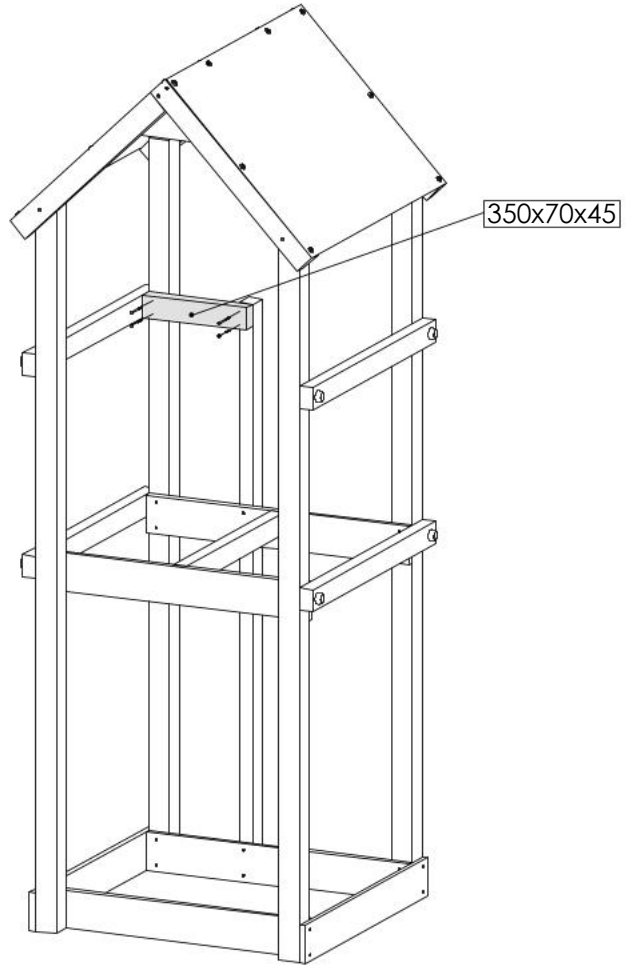

350x70x45

13



Cx24

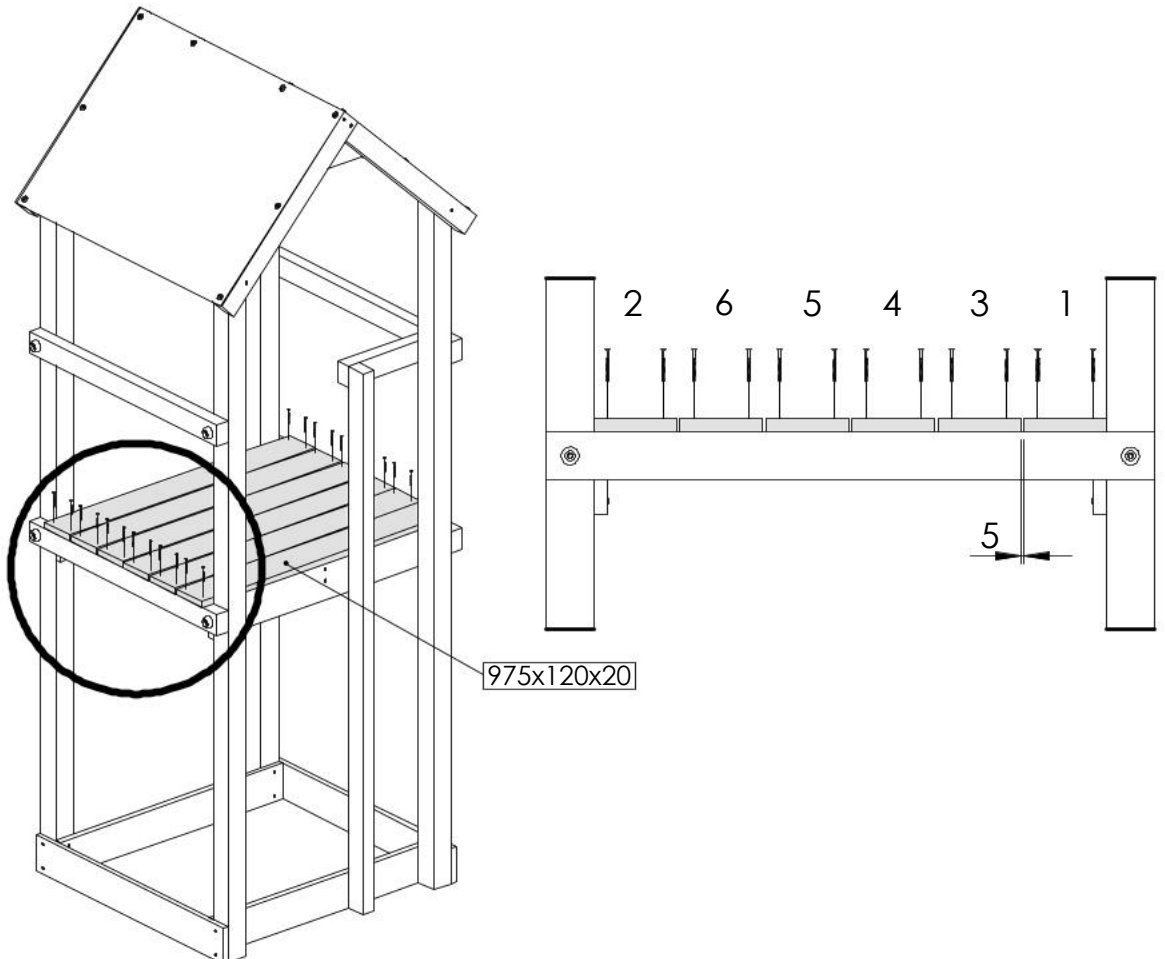

975x120x20

5

14

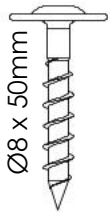

E<sub>x8</sub>

x4

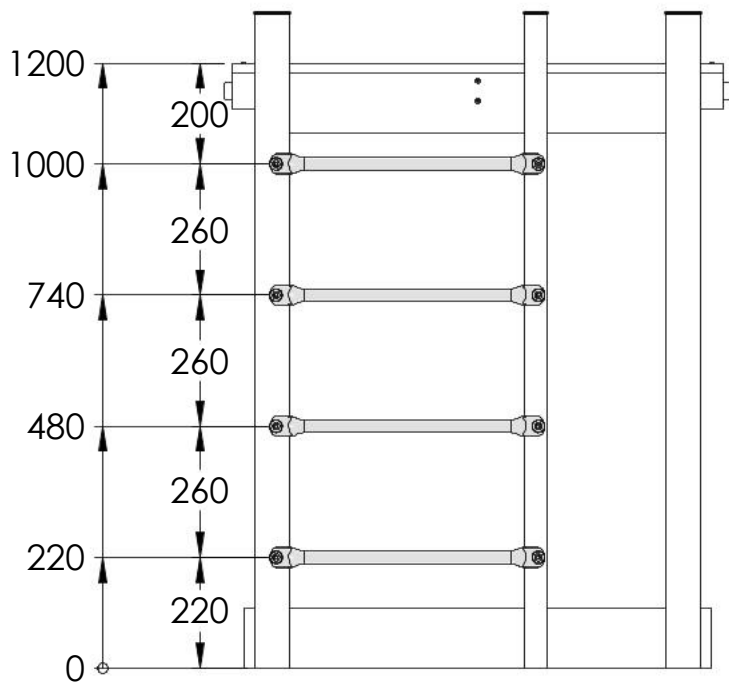
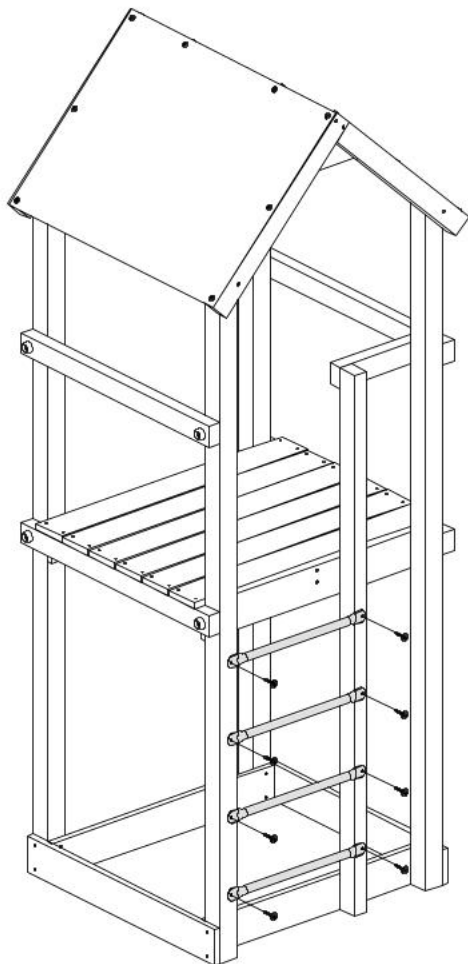
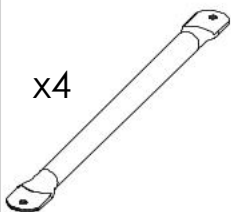

15



C<sub>x4</sub>

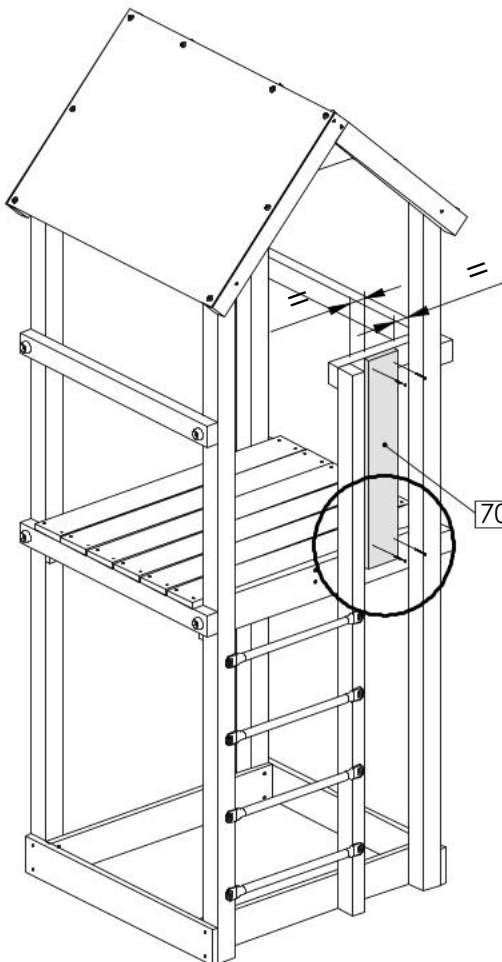

700x120x20

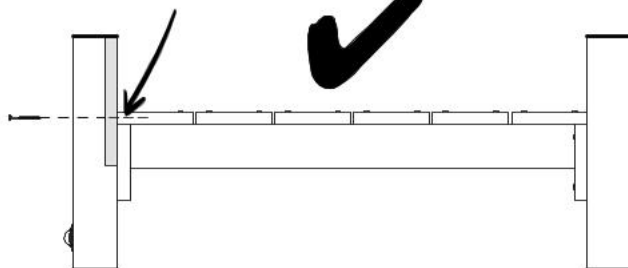
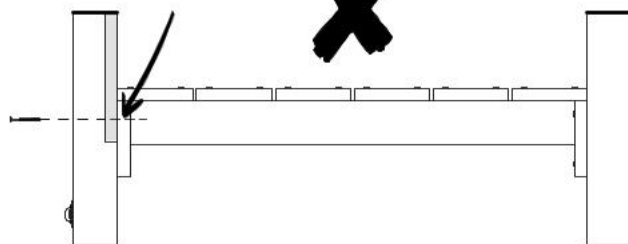

16



Cx16

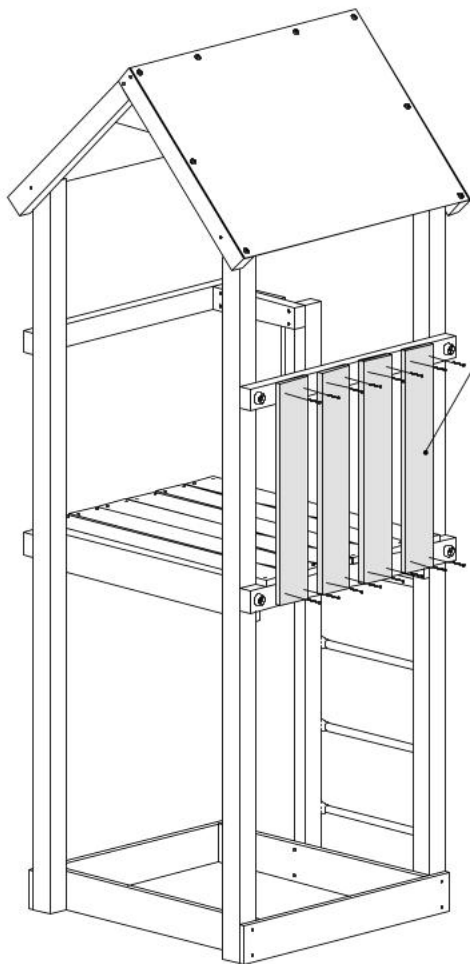

700x120x20

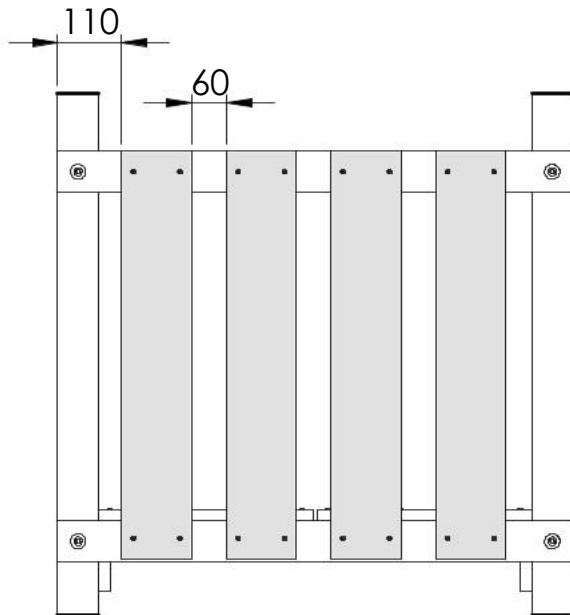

17



Bx2

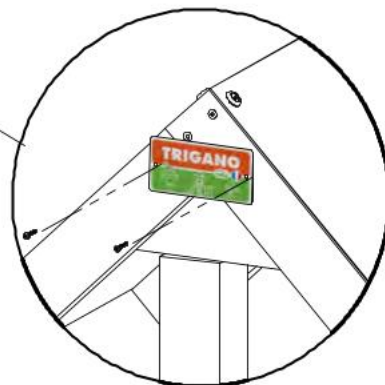
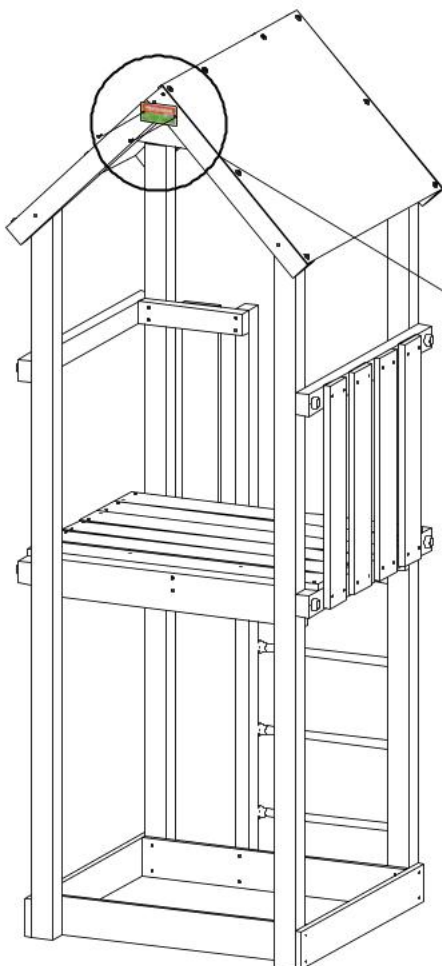

18

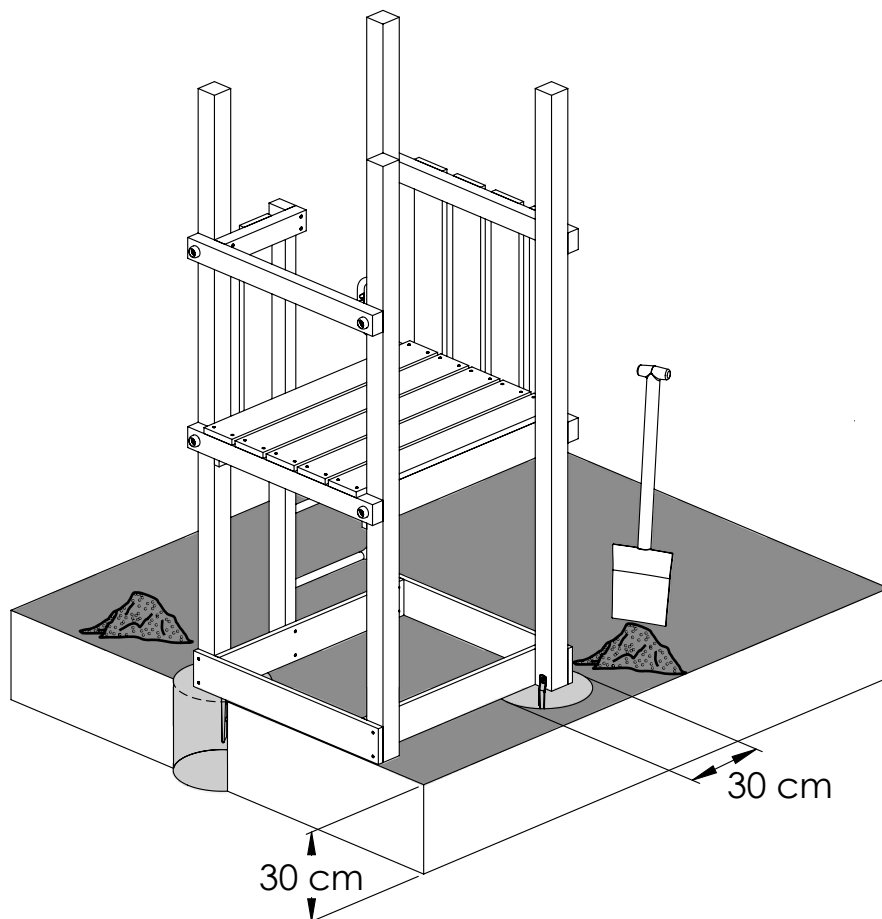
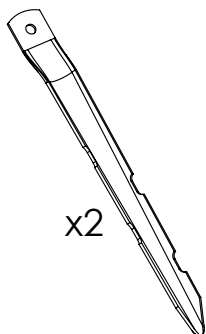
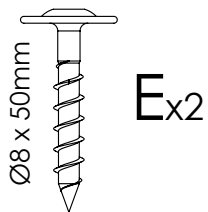

19

Vendu séparément  
 Sold separately  
 Getrennt verkauft  
 Apart verkocht  
 Venduto separatamente  
 Se vende por separado  
 Vendido separadamente  
 Sprzedawane oddzielnie  
 Prodano ločeno

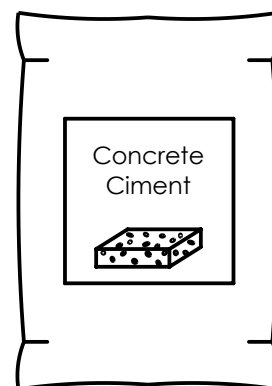
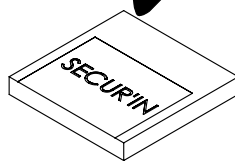

20

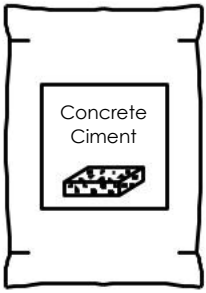

24H

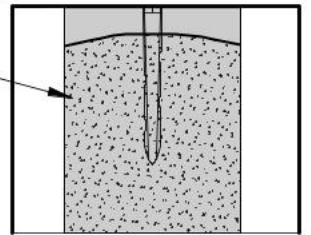
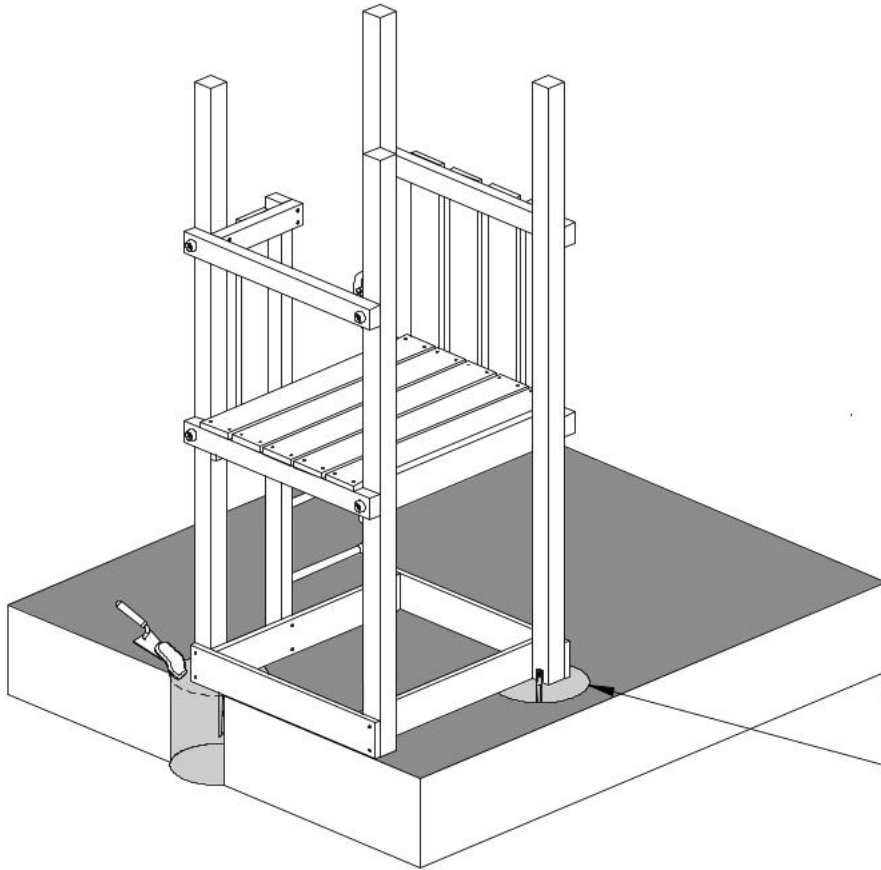

21

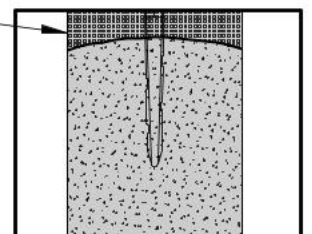
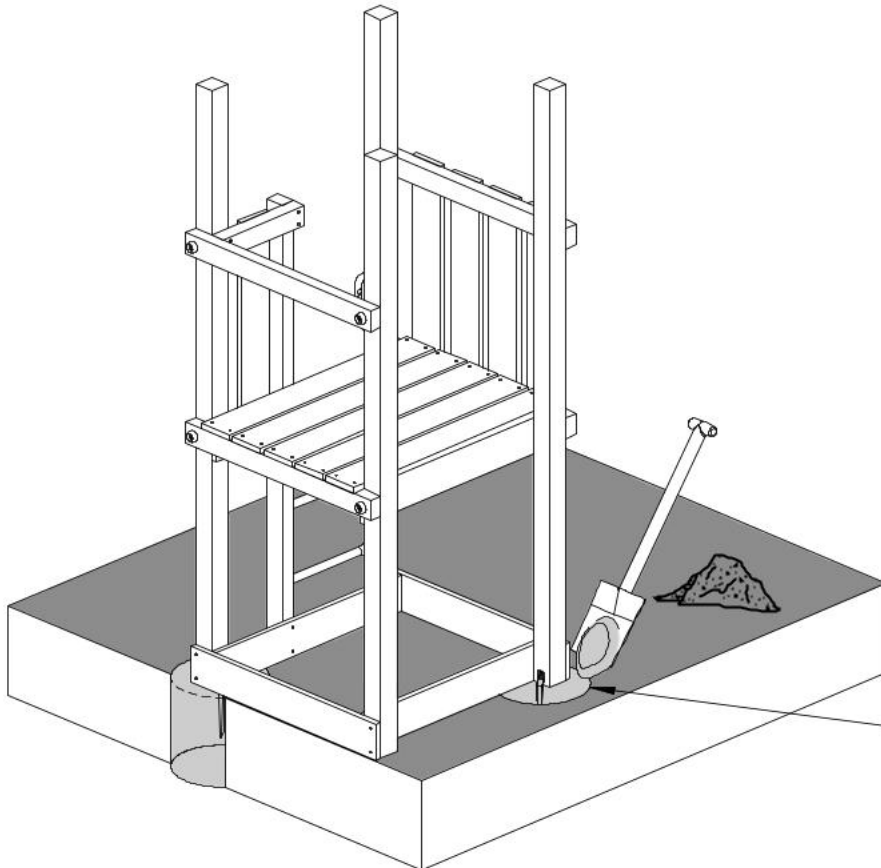

22



Cx32

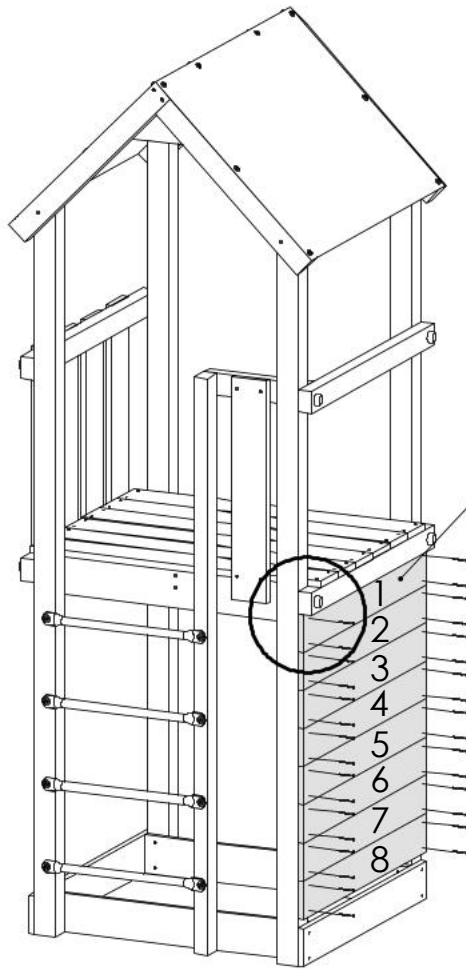

885x120x20

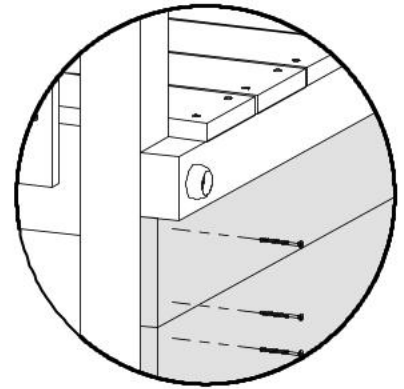

23



x10



x10



x5

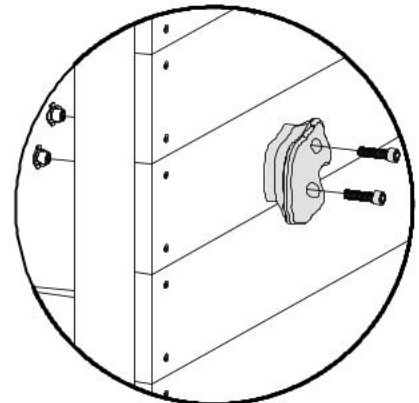
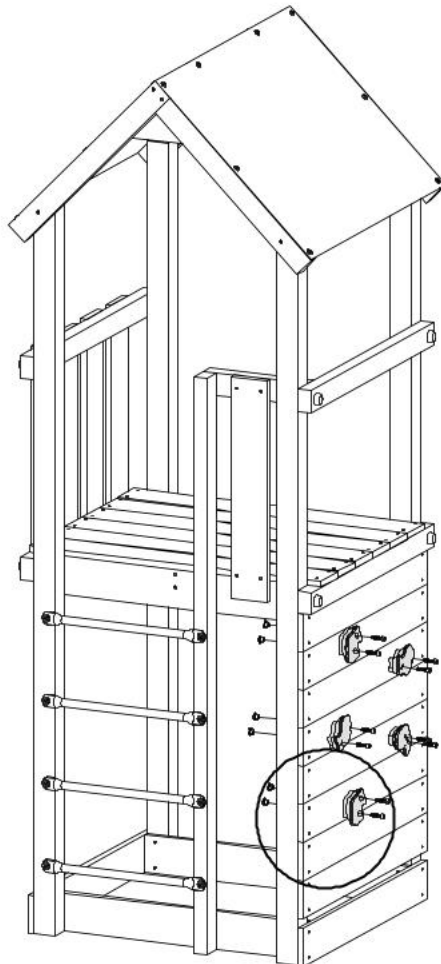

24

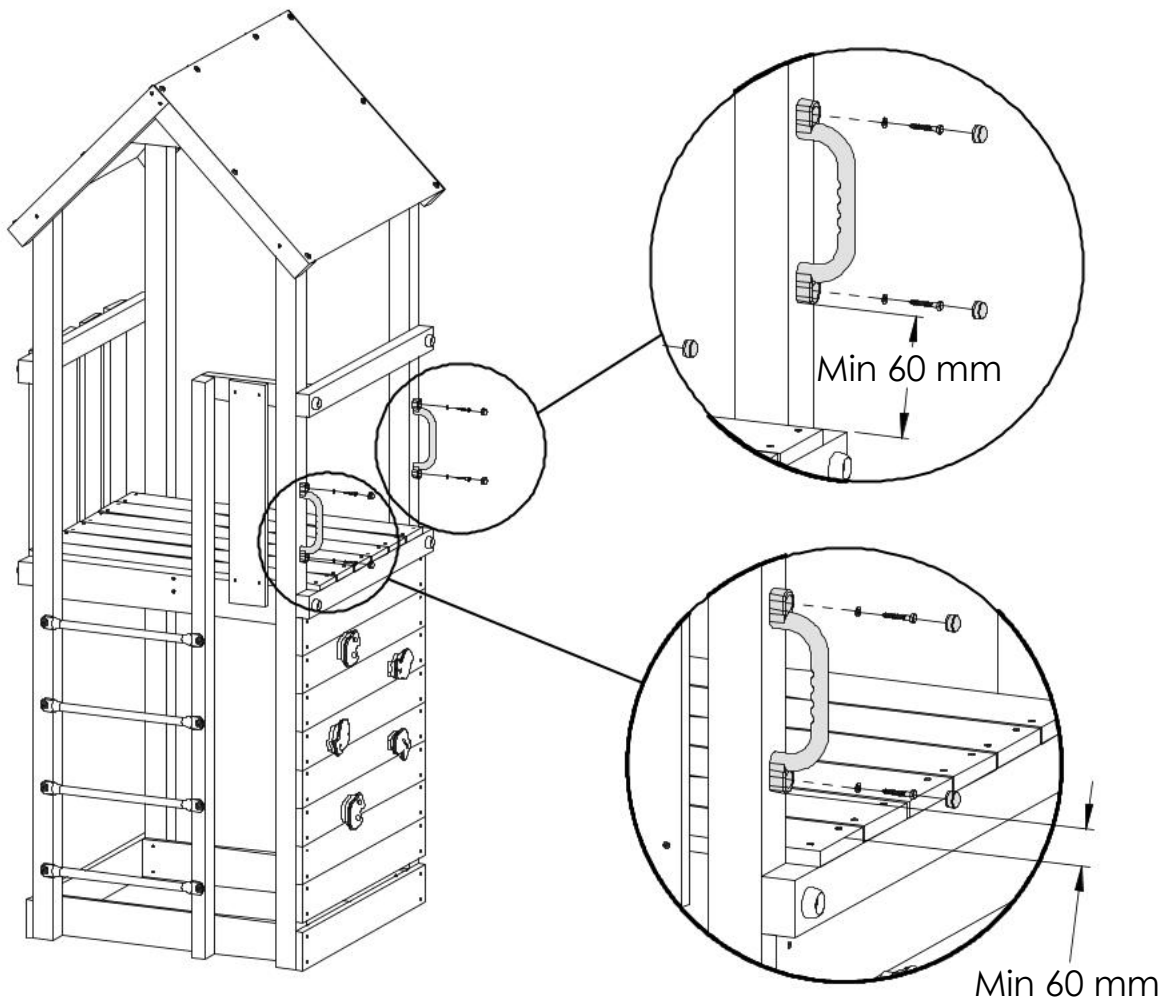
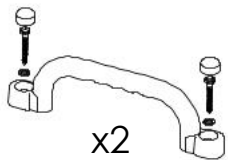

25

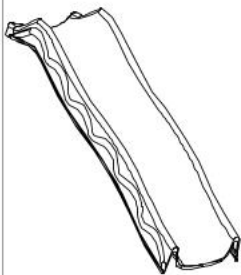

Ø7

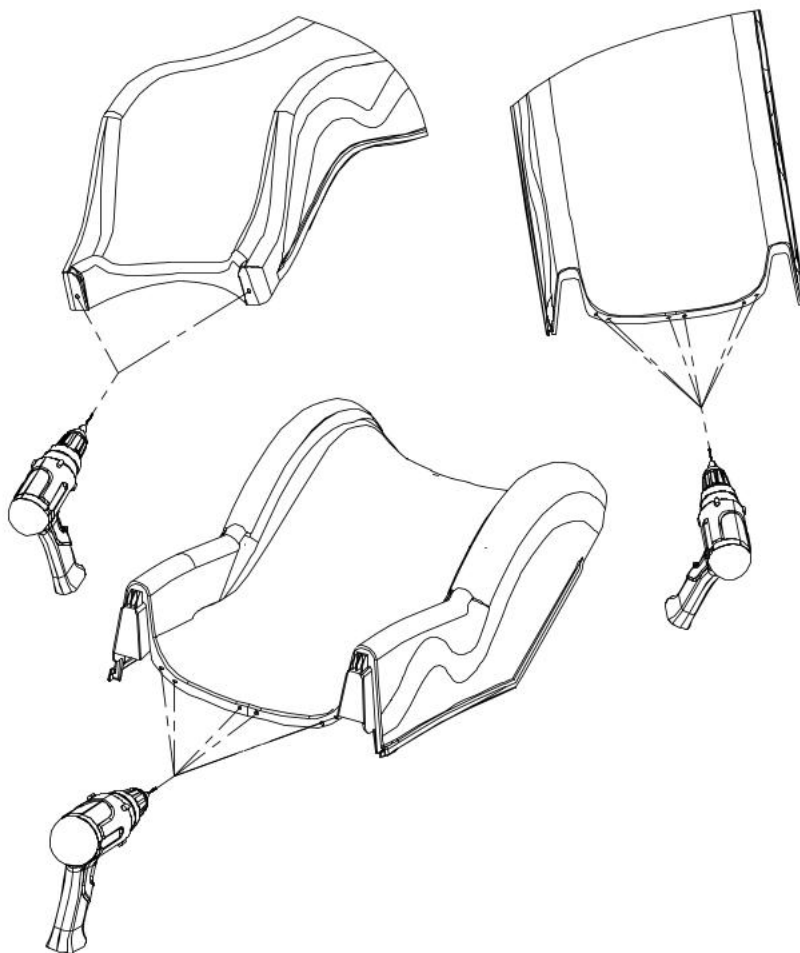
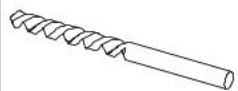

26

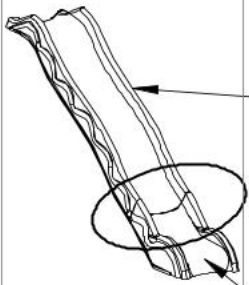

Ix6



Kx12



Jx6

M6

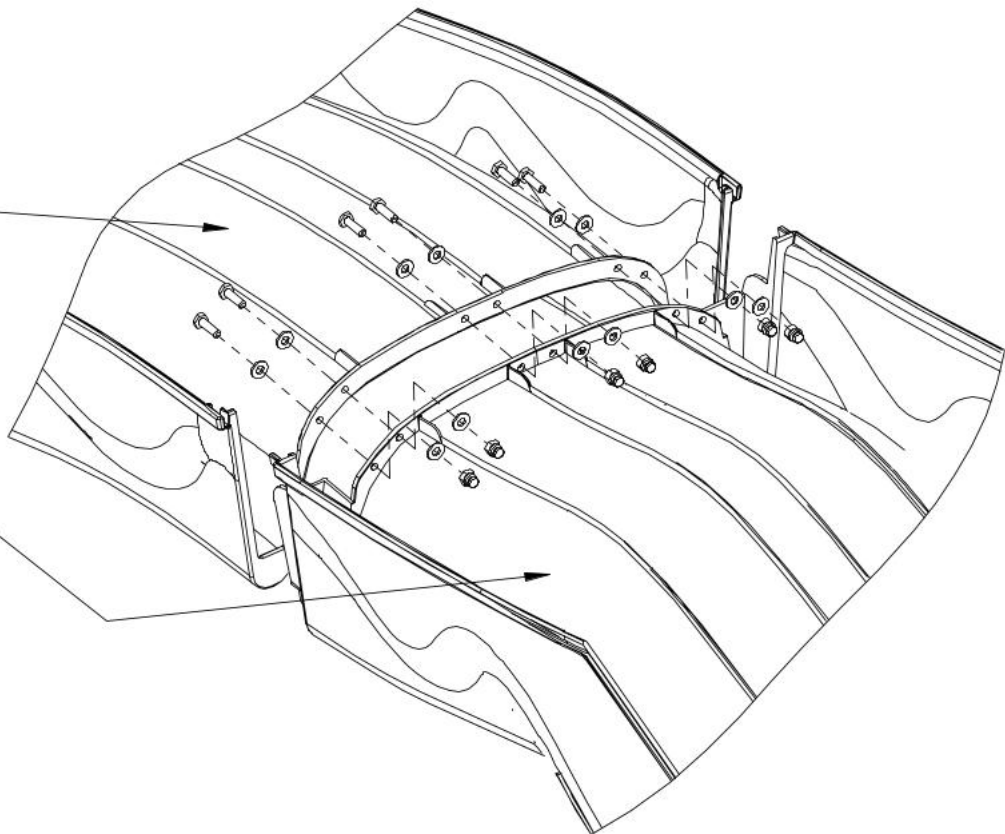

27

Ø7

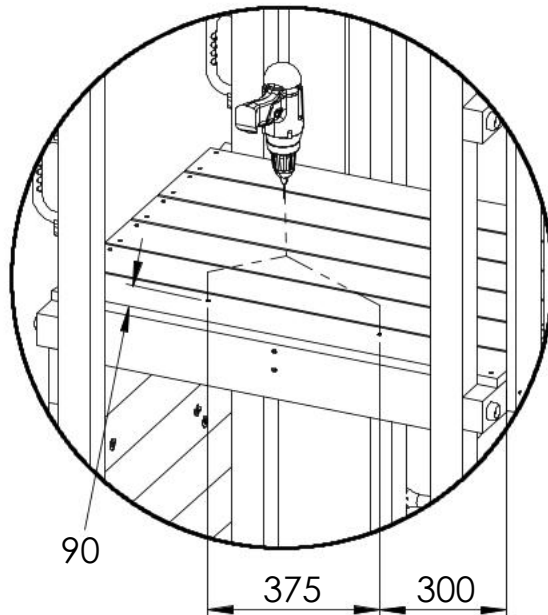
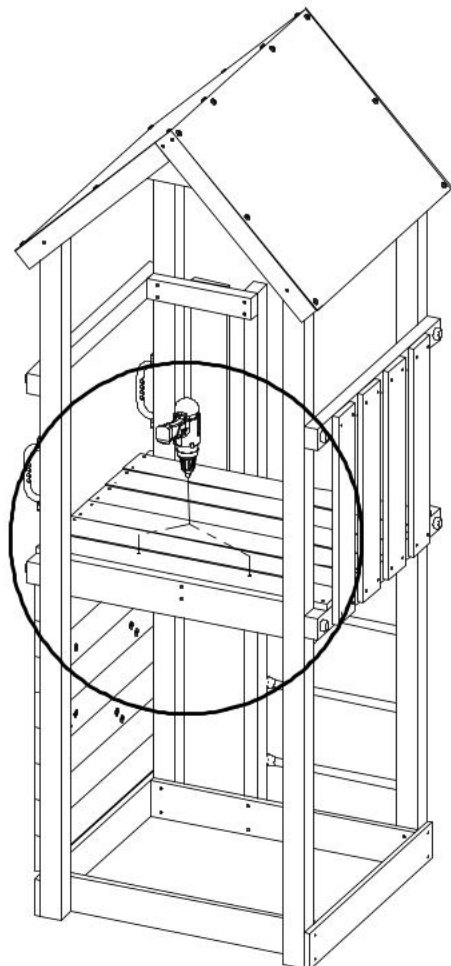

28



Hx2



Kx2



Ox2



Jx2

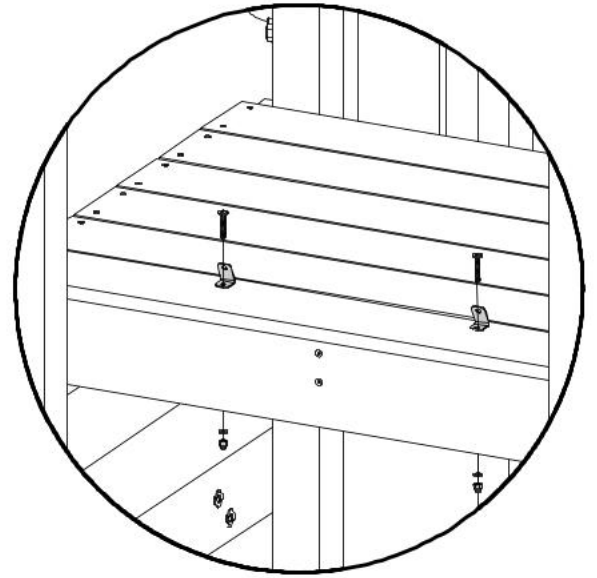
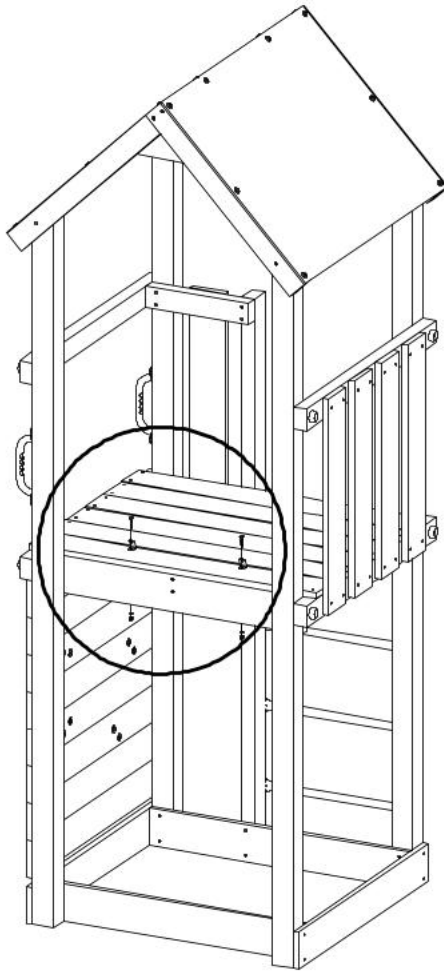

29



Gx2



Kx2



Jx2

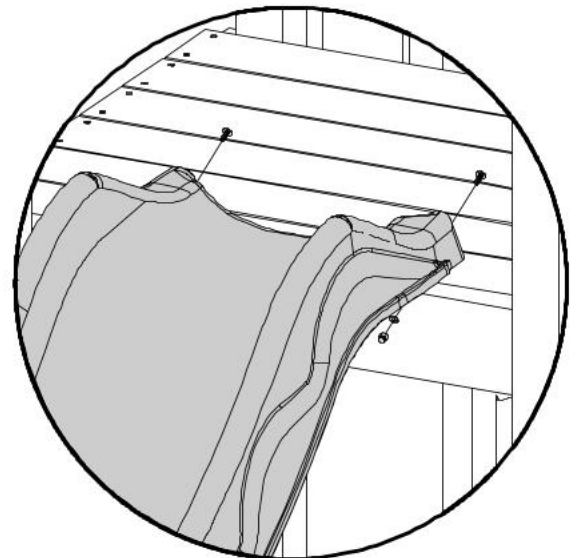
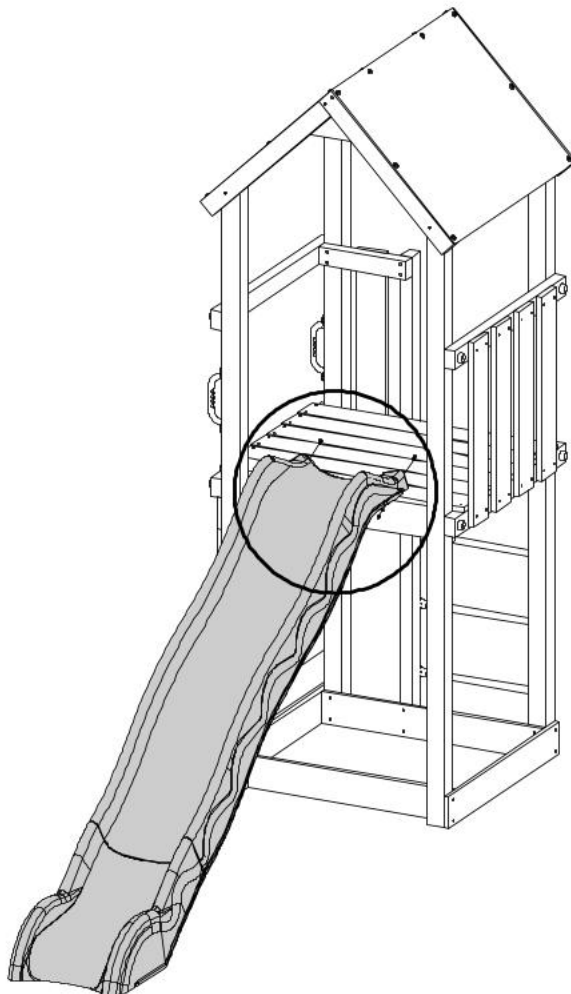

30

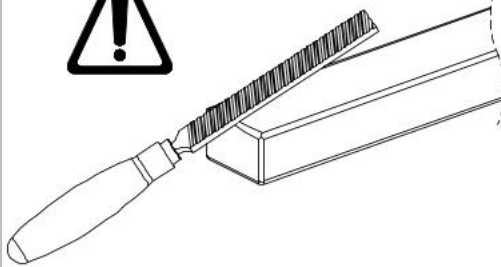
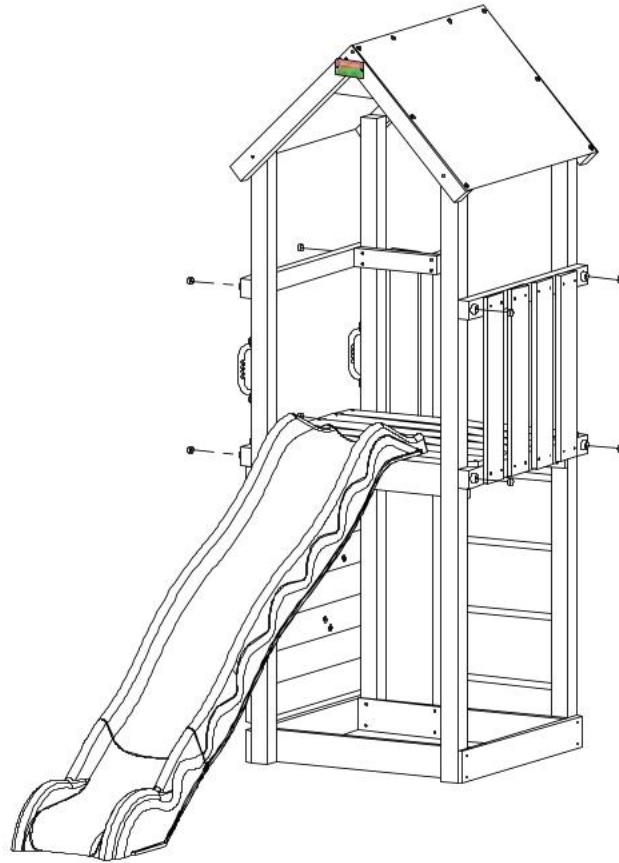

Veuillez arrondir les angles sur les bords exposés à un rayon minimum de 4mm  
Please round corners on exposed edges to a minimum radius of 4mm  
Bitte runden Sie Ecken an freiliegenden Kanten auf einen Mindestradius von 4 mm ab  
Rond hoeken aan blootliggende randen af met een straal van minimaal 4 mm  
Si prega di arrotondare gli angoli sui bordi esposti a un raggio minimo di 4 mm  
Redondea las esquinas de los bordes expuestos a un radio mínimo de 4 mm  
Por favor, arredondar os cantos nas bordas expostas para um raio mínimo de 4 mm  
Proszę zaokrąglić rogi odsoniętych krawędzi do minimalnego promienia 4 mm  
Zaokrožite vogale izpostavljenih robov na najmanjši polmer 4 mm

Merci d'avoir choisi Trigano  
Thanks for choosing Trigano

