



J-ABR261

Abri en métal

2.25 x 2.53 m

Instructions de montage

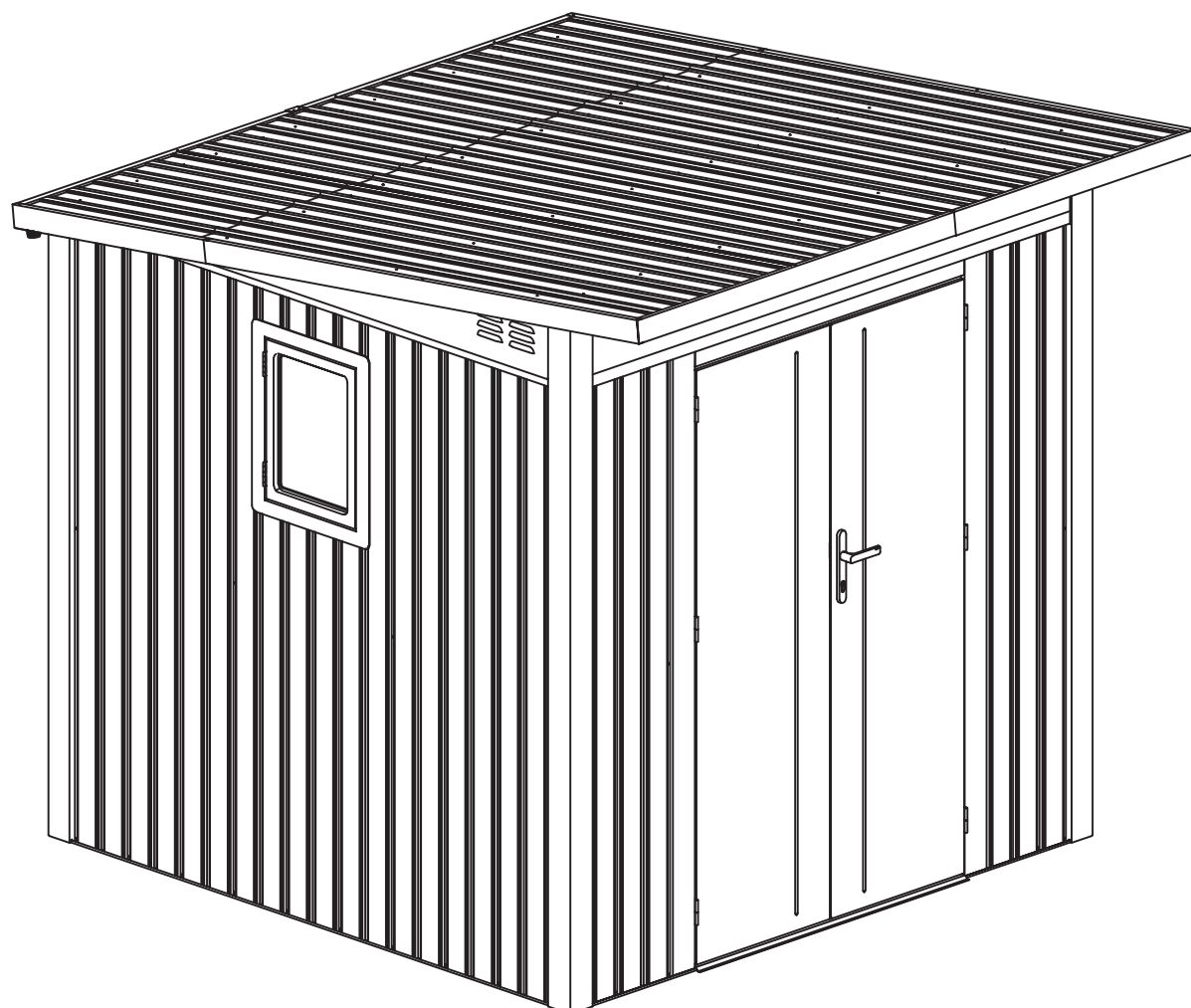

2 PERSONNES REQUISES





J-ABR261  
ABRI DE JARDIN

## Manuel du propriétaire

Veillez consulter les normes de construction locales relatives à l'emplacement de votre abri et aux autres exigences avant de commencer le montage.

### Instructions de montage

Lisez toutes les instructions et informations appropriées avant de commencer le montage. Assurez-vous de suivre attentivement l'ordre des étapes afin d'obtenir de bons résultats.

Résistance à la neige 50Kg/m<sup>2</sup>.

### Accueil de l'abri

Vous devez décider d'un emplacement pour votre abri avant le montage, choisissez un emplacement plat et de niveau, pour permettre à l'eau de s'évacuer.

Préférez un endroit avec une exposition limitée aux vents dominants, notamment sur les faces comportant des ouvertures. L'accueil doit être d'environ 10 cm plus large que le support de l'abri (une dalle de béton d'une épaisseur minimale de 10 cm est recommandée).

Assurez-vous de disposer d'un espace de travail suffisant pour positionner aisément les pièces lors du montage. Veillez à ce que l'entrée soit suffisamment dégagée pour permettre une ouverture complète des portes, et prévoyez assez d'espace autour de l'abri pour fixer les vis de l'extérieur.

La condensation dans un abri de jardin est principalement causée par l'humidité présente dans les fondations. Cette humidité se diffuse dans l'air chaud à l'intérieur de l'abri, puis se condense sur les surfaces froides des murs et du toit en métal, formant des gouttelettes.

Pour lutter contre la condensation, il est essentiel de prévenir l'humidité dans les fondations de l'abri. Voici quelques étapes à suivre avant l'installation d'un abri métallique :

### Préparation de la fondation :

La dalle de béton ou la fondation doit être à peine plus grande que la surface de l'abri et parfaitement horizontale. Construisez la base de manière à permettre l'écoulement de l'eau. Les bords de la base en ciment doivent être inclinés pour faciliter l'écoulement de l'eau.

Exemple : Surface de l'abri = 2,36 m x 1,77 m et fondation = 2,43 m x 1,85 m.

### Imperméabilisation :

Insérez une membrane imperméable à l'humidité avant de couler la dalle. Utilisez une toile de polythène épaisse et résistante sous la base pour empêcher l'humidité de monter du sol dans l'abri.

Après le coulage du béton, laissez sécher la fondation pendant au moins 7 jours.

### Isolation et ventilation :

Recouvrez le toit de l'abri de jardin avec du feutre pour améliorer l'isolation.

Ouvrez périodiquement une porte ou une fenêtre de l'abri pour permettre à l'air frais et sec de circuler.

### Application de mastic :

Appliquez un mastic pour extérieur sur les pièces d'armature de la base de l'abri. Ce mastic ne doit pas sécher complètement et doit rester souple.

### Panneaux de polystyrène :

Si la condensation persiste, collez des panneaux de polystyrène de 25 mm d'épaisseur sous les panneaux de toiture entre les poutres du toit. Utilisez une colle pour métal résistante à l'humidité et à la température. Ces panneaux aident à maintenir une température plus fraîche à l'intérieur de l'abri pendant les journées chaudes.

En suivant ces étapes, vous pouvez réduire l'excès d'humidité dans les fondations et minimiser la condensation dans votre abri de jardin.

**Ancrage :** Votre abri de stockage doit être ancré afin d'éviter les dommages dus au vent.

## Pièces de l'abri

Avant de commencer le montage, assurez-vous de disposer de la totalité des pièces nécessaires pour le montage de votre abri (reportez-vous à la page « Liste des pièces » en page 5). N'essayez pas de monter l'abri s'il vous manque des pièces.

Tout abri partiellement monté peut être gravement endommagé par des vents légers.

Veillez retirer la couche de protection de sécurité avant de commencer le montage.

Si nécessaire, conservez l'étiquette où figure le numéro de la pièce.

## Outils nécessaires (liste non exhaustive)



## La sécurité doit être la priorité

1. Choisissez une journée calme et sèche pour le montage. Le montage doit être effectué à plusieurs personnes (deux monteurs au minimum). Il est également recommandé de terminer le montage en une journée afin d'éviter d'endommager le produit ou de perdre des petites pièces. Conservez toutes les petites pièces (vis, etc.) dans un contenant pour ne pas les perdre.
2. Portez des gants de sécurité, des lunettes de protection et des manches longues pendant le montage afin d'éviter les blessures. Faites attention au bord tranchant de certaines pièces.
3. Gardez les enfants et les animaux domestiques hors du lieu de montage.
4. Ne reposez jamais tout votre poids sur le toit de l'abri. Assurez-vous d'être en sécurité avant d'utiliser un escabeau.

## Entretien et maintenance

1. Nettoyez l'abri avec un chiffon doux, en utilisant de l'eau si nécessaire.
2. Veillez à enlever les saletés et autres débris qui pourraient empêcher les rails de porte de coulisser facilement.
3. L'abri n'est pas fait pour y vivre. Il est destiné au stockage.
4. Lubrifiez les glissières supérieure et inférieure afin de garantir que la porte coulisse facilement.
5. Veillez à ne pas laisser les portes ouvertes.
6. Ne laissez pas la neige s'accumuler sur le toit.

## Utilisation

Il est déconseillé de stocker des produits chimiques à l'intérieur de l'abri.

## Garantie

5 ans contre la perforation par la rouille.

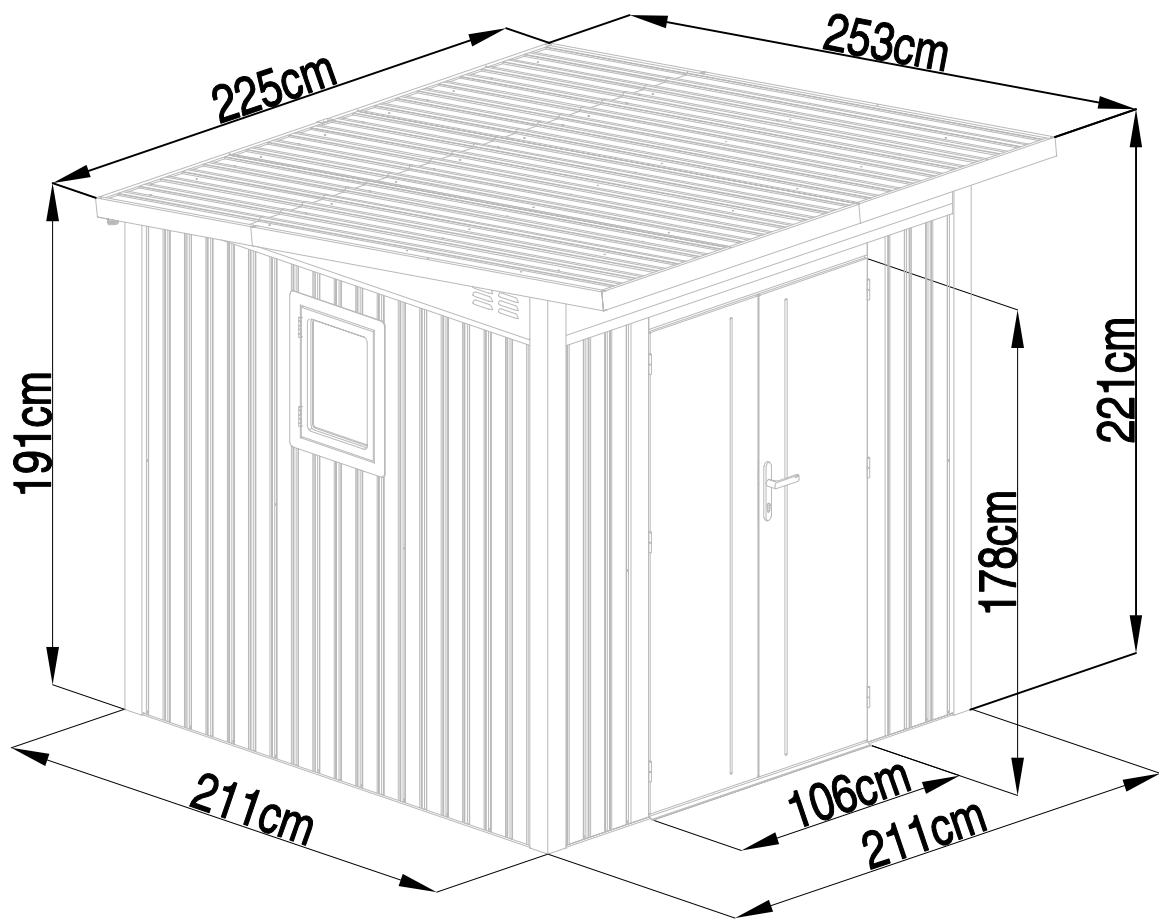

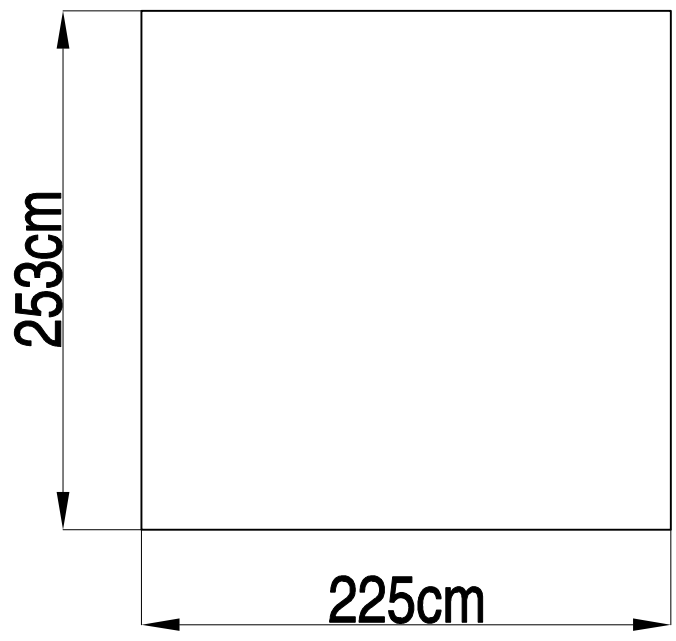

Area of installation requirement:







<b>1</b>	 Ac-A1 x1	 Ana-A2 x1	 Ana-B3 x2	
----------	---	--	--	--

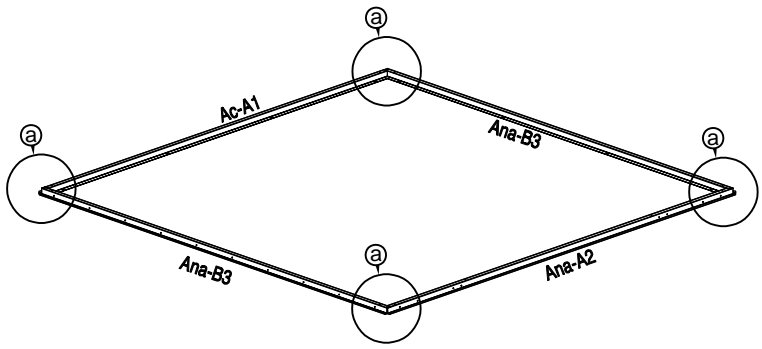
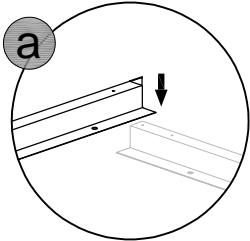

<b>2</b>	 Ab-4 x4	 Anx-B41 x12	
----------	--	--	--

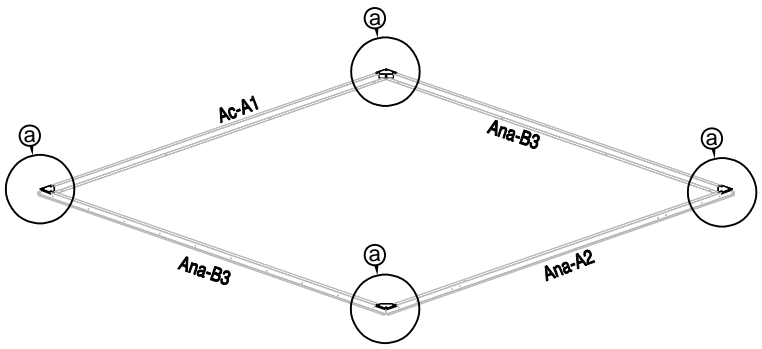
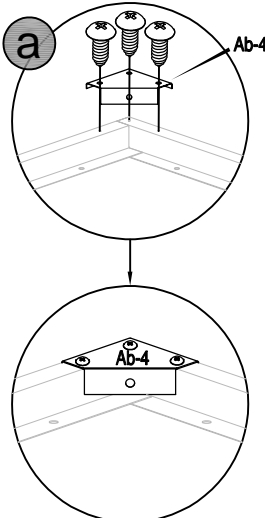

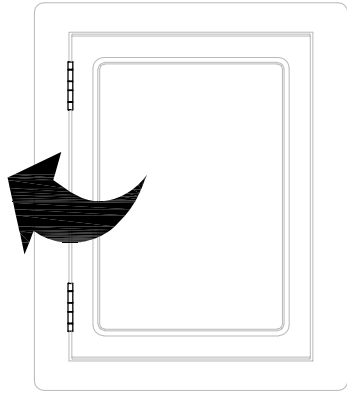



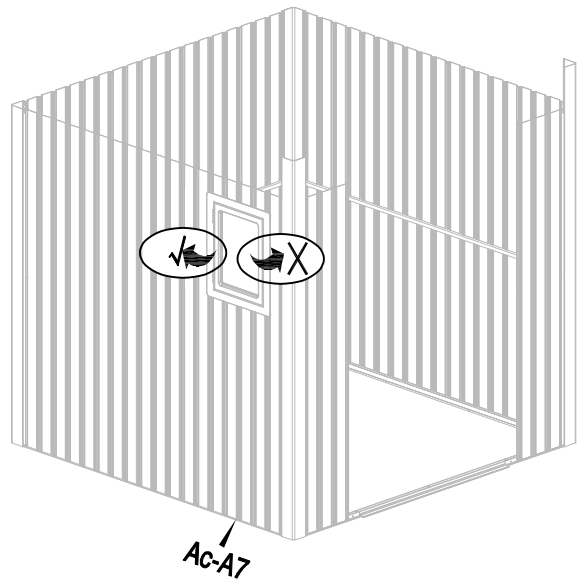
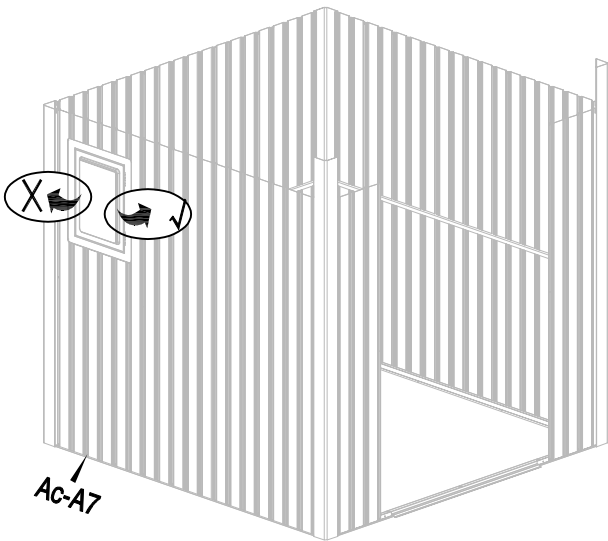
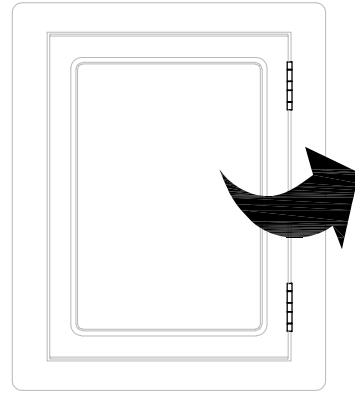

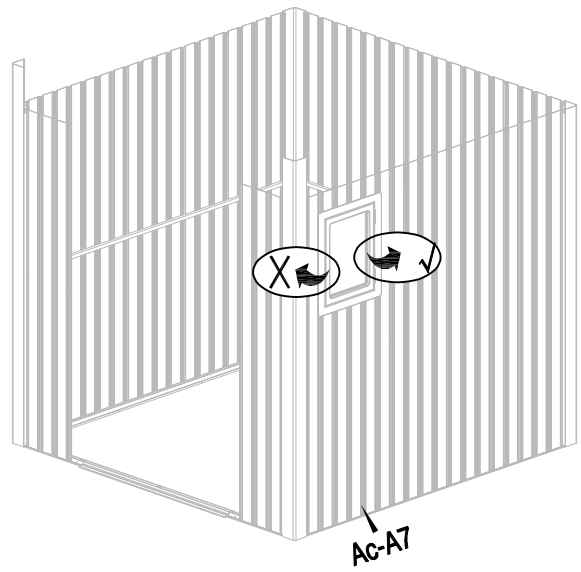
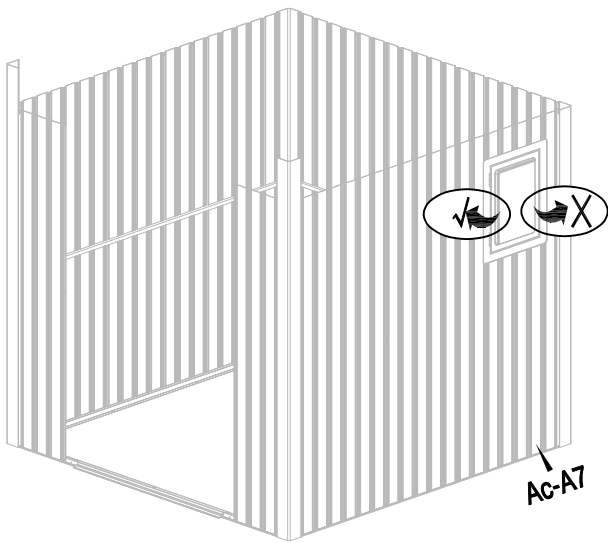
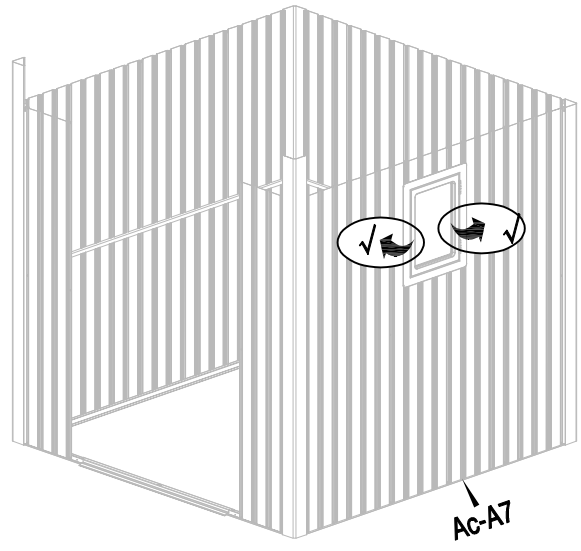
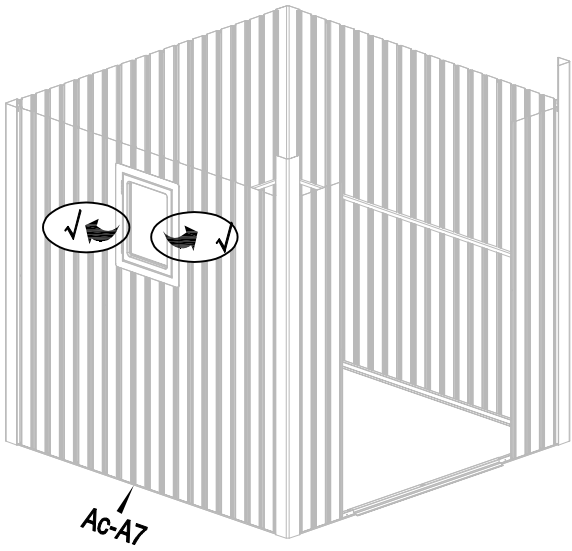



Or



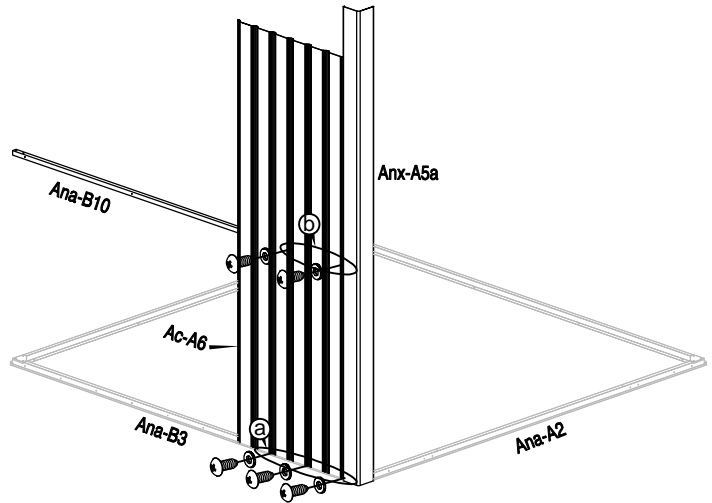
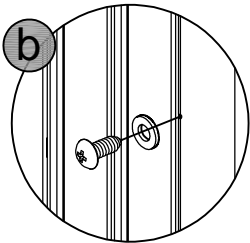
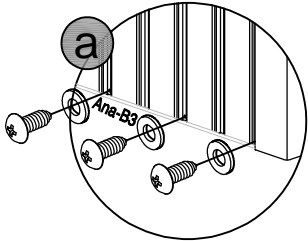
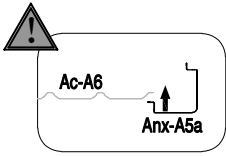

3	 Ac-A6 x1	 Anx-A5a x1	 Ana-B10 x1	 Anx-B41 x5	 Anx-B40 x5	
---	---	---	---	--	---	--



4	 Ac-A8 x1	 Ac-A11 x1	 Anx-B41 x3	 Anx-B40 x3	
---	---	--	---	--	--

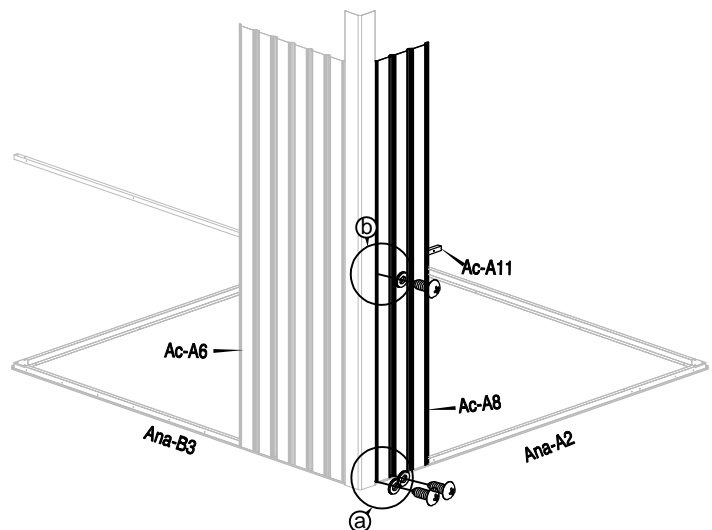
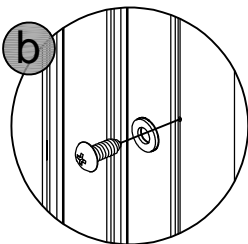
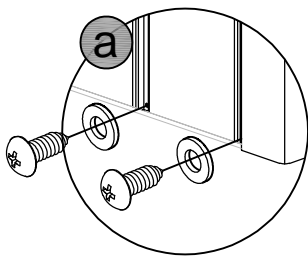



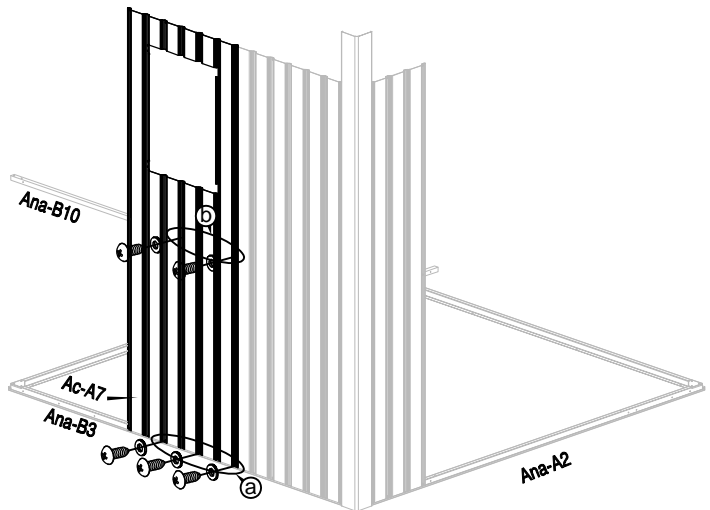
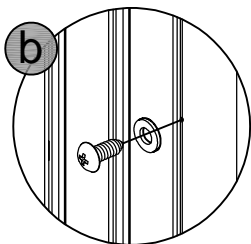
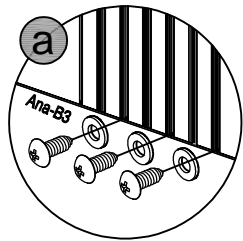

5				
	Ac-A7 x1	Anx-B41 x5	Anx-B40 x5	

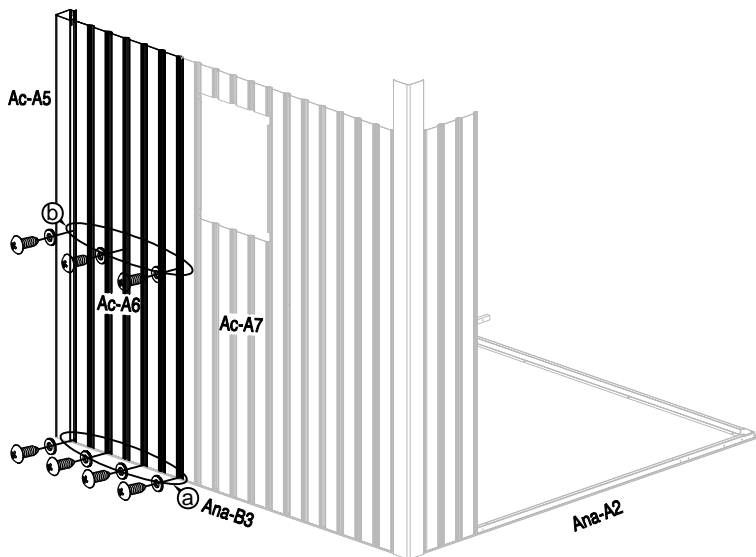
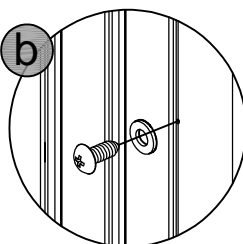
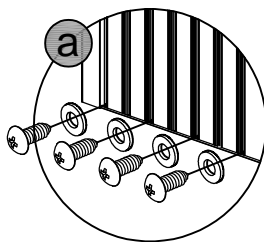



6					
	Ac-A6 x1	Ac-A5 x1	Anx-B41 x7	Anx-B40 x7	



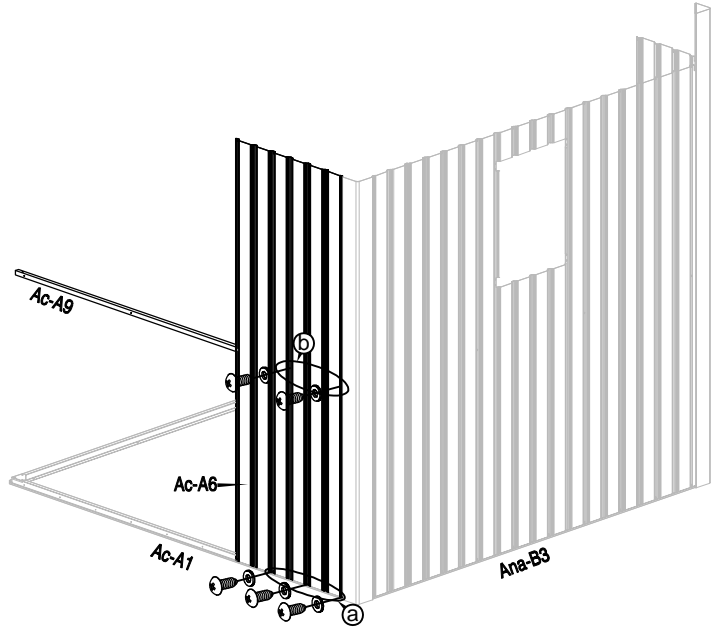
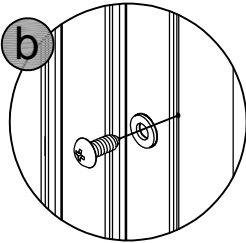
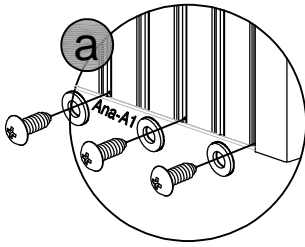



7	 Ac-A6 x1	 Ac-A9 x1	 Anx-B41 x5	 Anx-B40 x5	
---	---	---	---	--	--

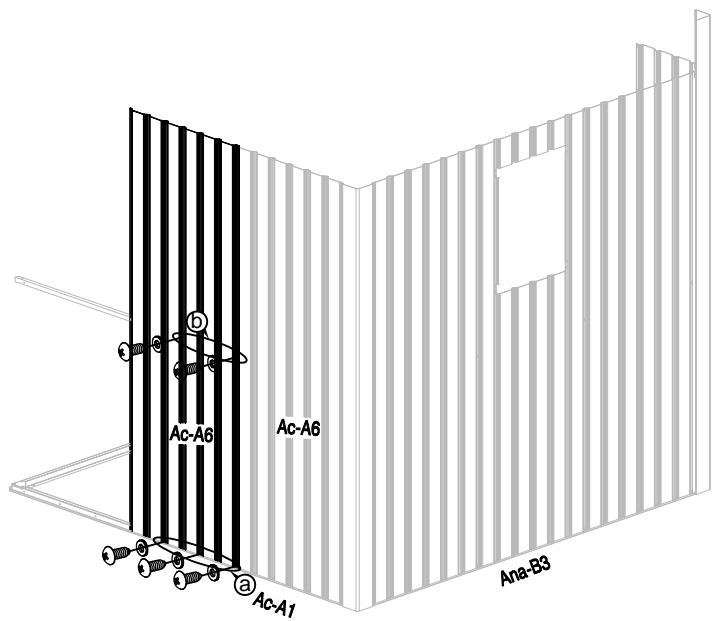
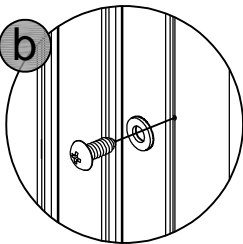
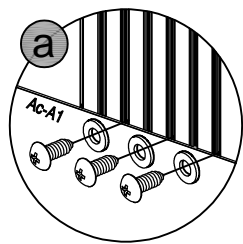





8	 Ac-A6 x1	 Anx-B41 x5	 Anx-B40 x5	
---	---	---	---	--

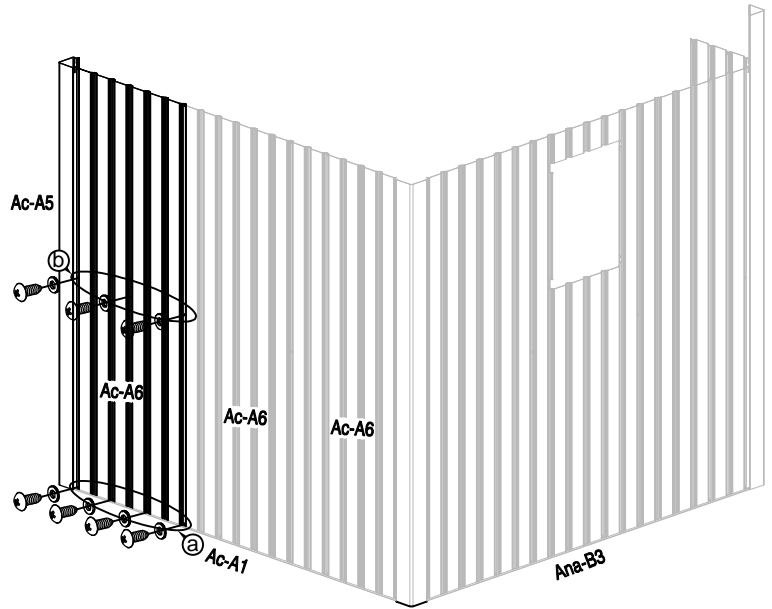
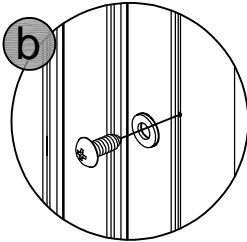
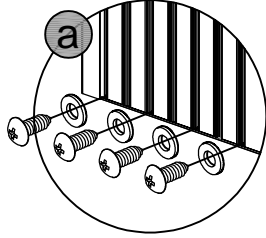

9	 Ac-A6 x1	 Ac-A5 x1	 Anx-B41 x7	 Anx-B40 x7	
---	---	---	---	--	--



10	 Ac-A6 x1	 Ana-B10 x1	 Anx-B41 x5	 Ana-A40 x5	
----	---	---	---	--	--

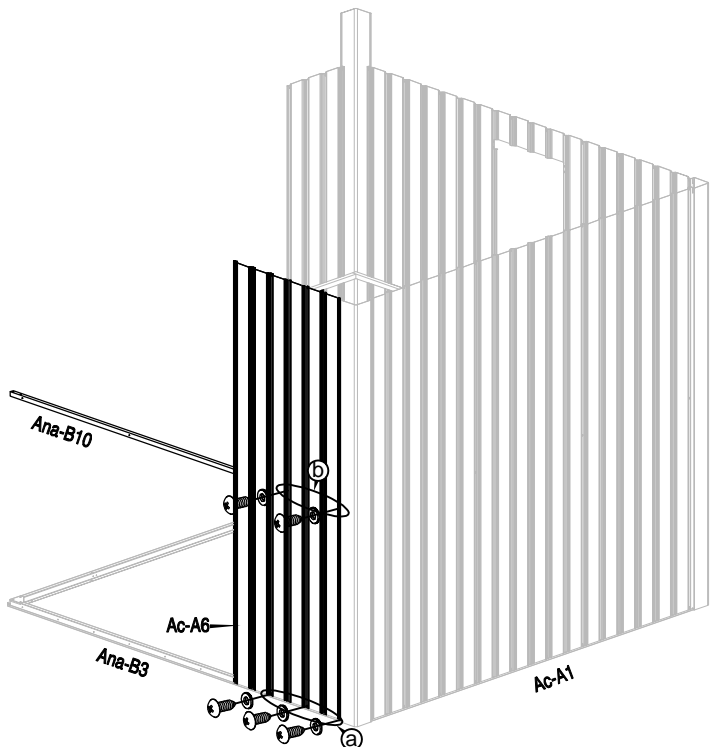
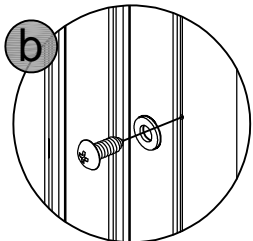
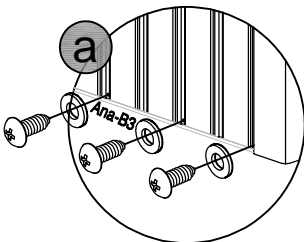

11



Ac-A6 x1



Anx-B41 x5



Anx-B40 x5

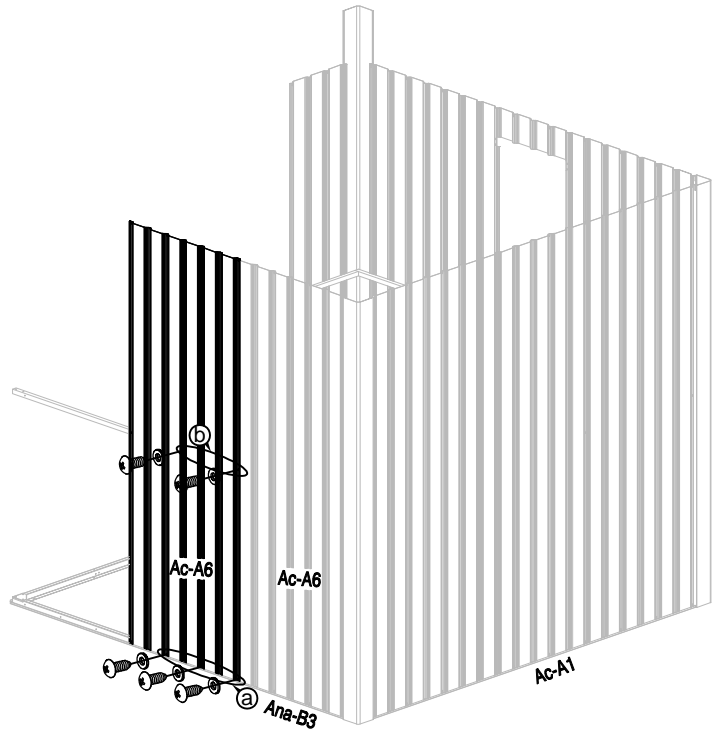
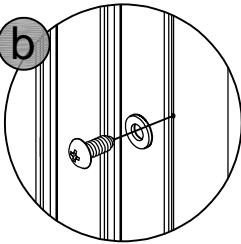
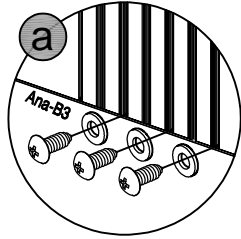

12



Ac-A6 x1



Anx-A5 x1







Anx-B41 x7

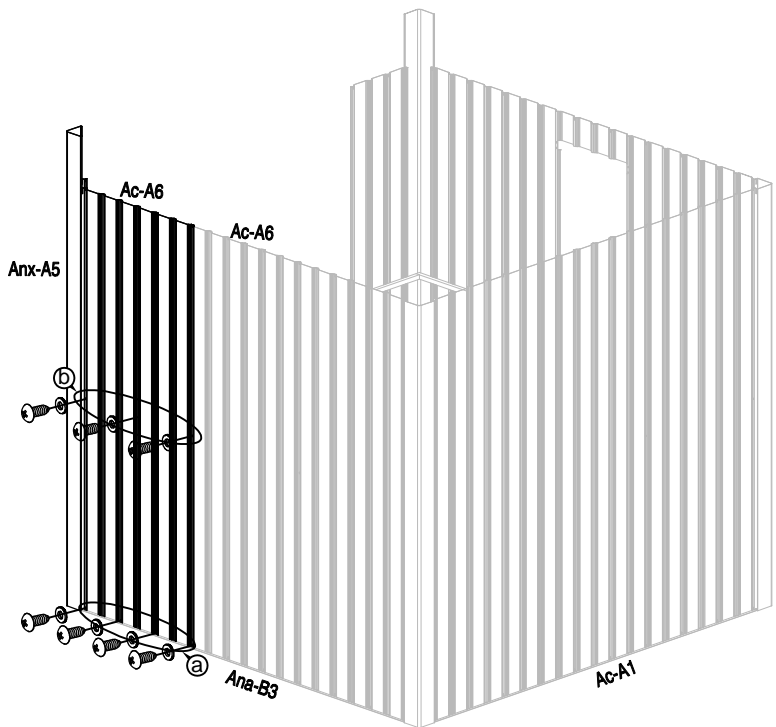
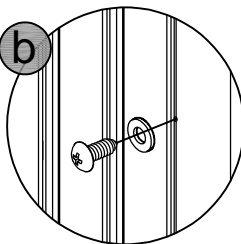
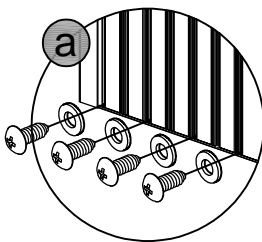

Anx-B40 x7



13	 Ac-A8 x1	 Ac-A11 x1	 Anx-B41 x3	 Anx-B40 x3	
----	---	--	---	--	--

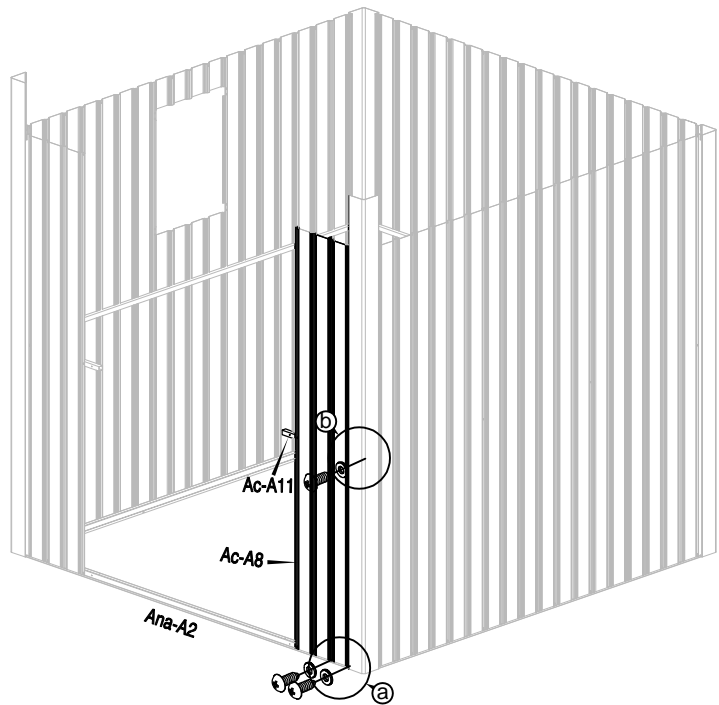
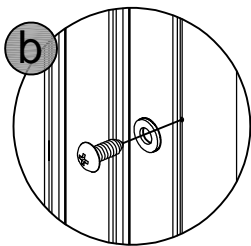
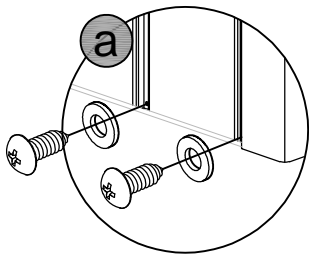



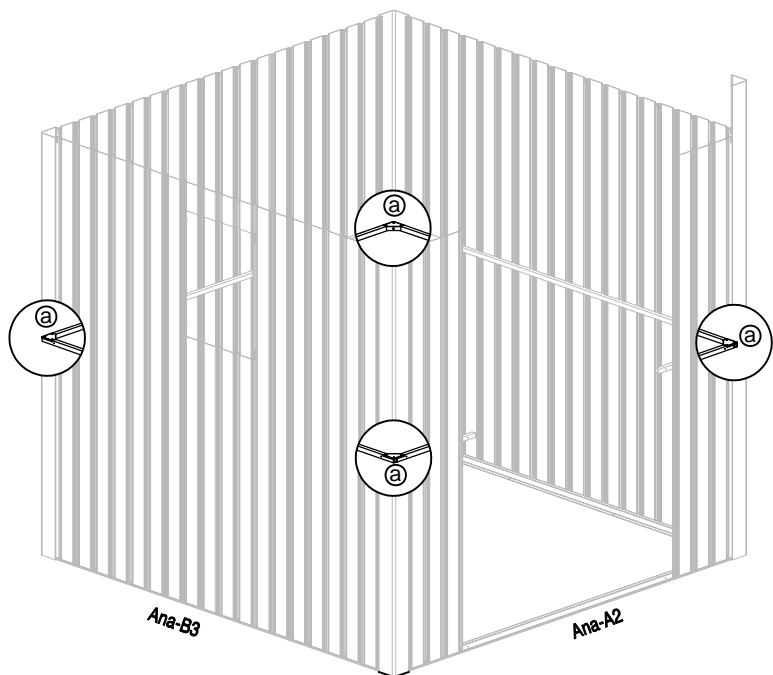
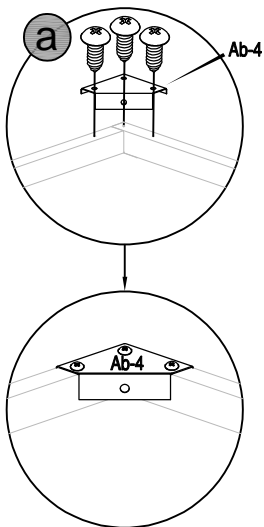

14	 Ab-4 x4	 Anx-B41 x12	
----	--	--	--

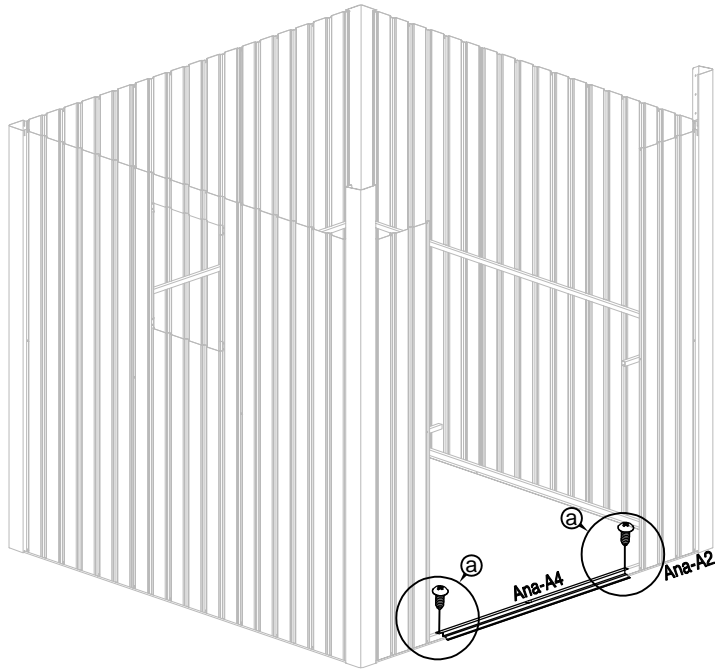
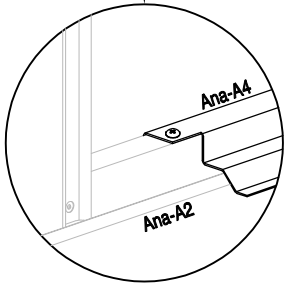
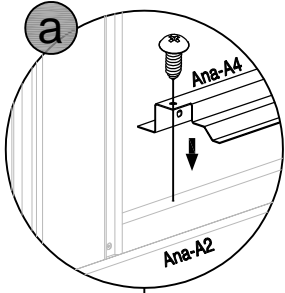
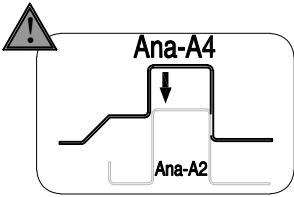

15	 Ana-A4 x1	 Anx-B41 x2	
----	--	---	--



16	 Ana-A16 x1	 Ana-A16a x1	 Anx-B41 x4	 Anx-B40 x4	
----	---	--	---	--	--

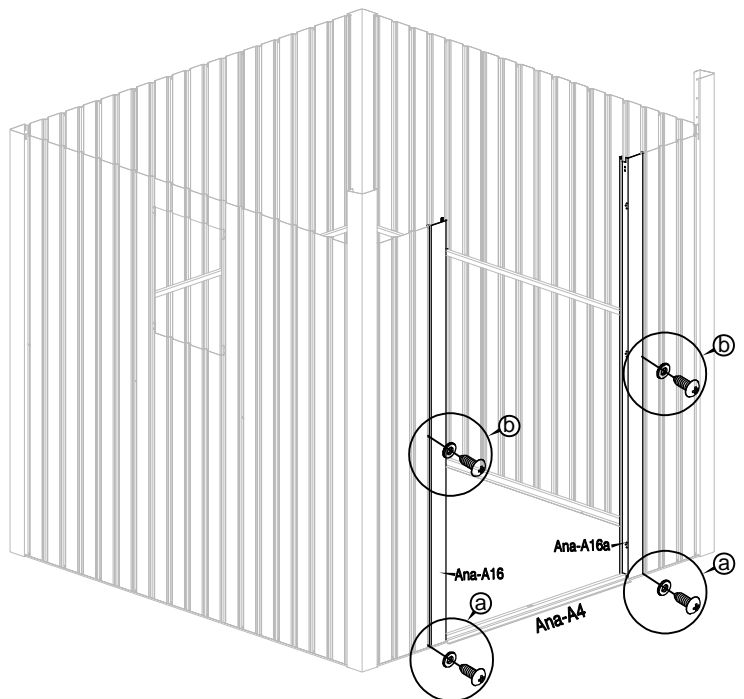
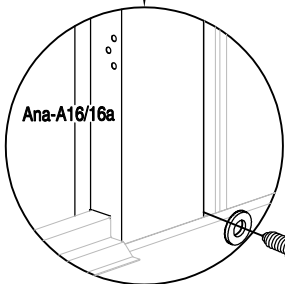
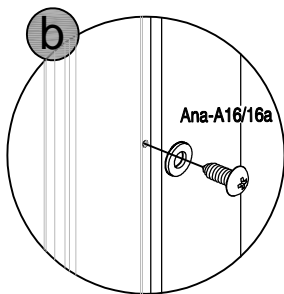
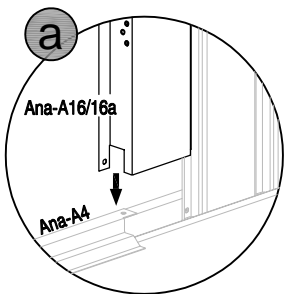

17



Anx-B41 x2

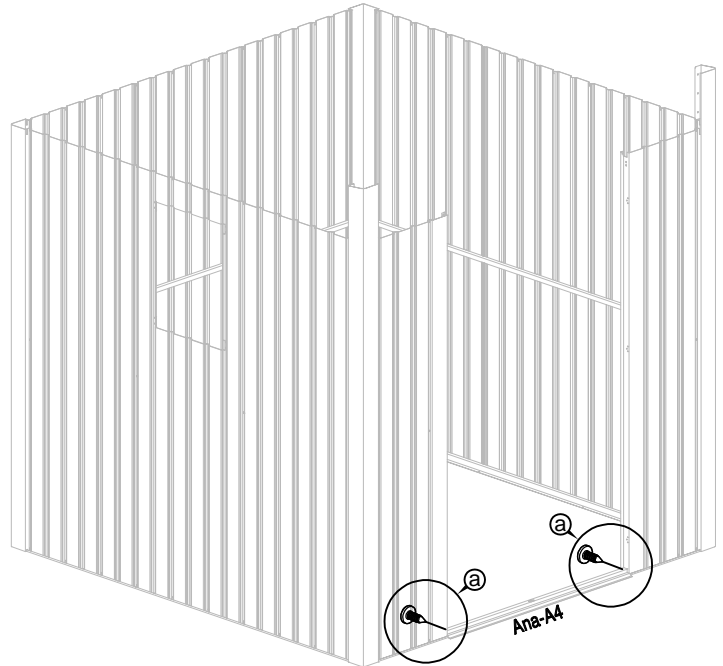
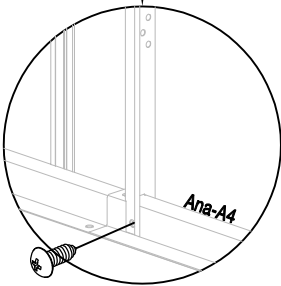
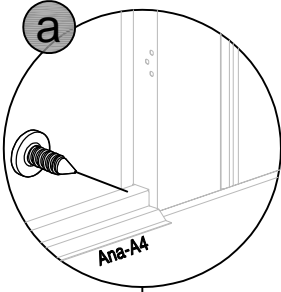

18



Ana-A13 x1



Anx-B14 x1







Anx-B41 x16

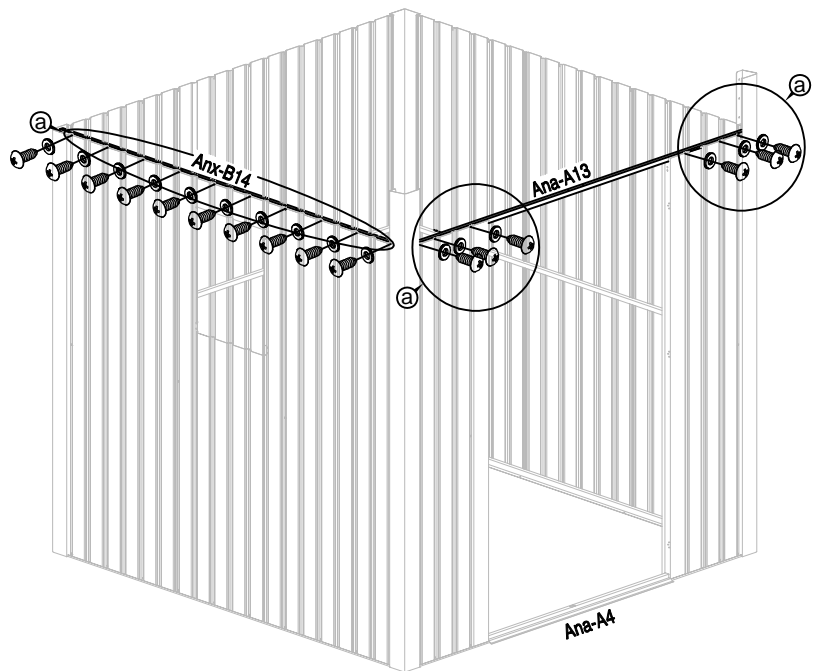
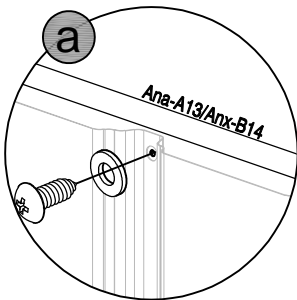
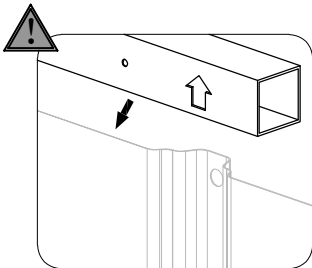

Anx-B40 x16



19	 Ac-A12 x1	 Anx-B14 x1	 Anx-B41 x20	 Anx-B40 x20	
----	--	---	--	---	--

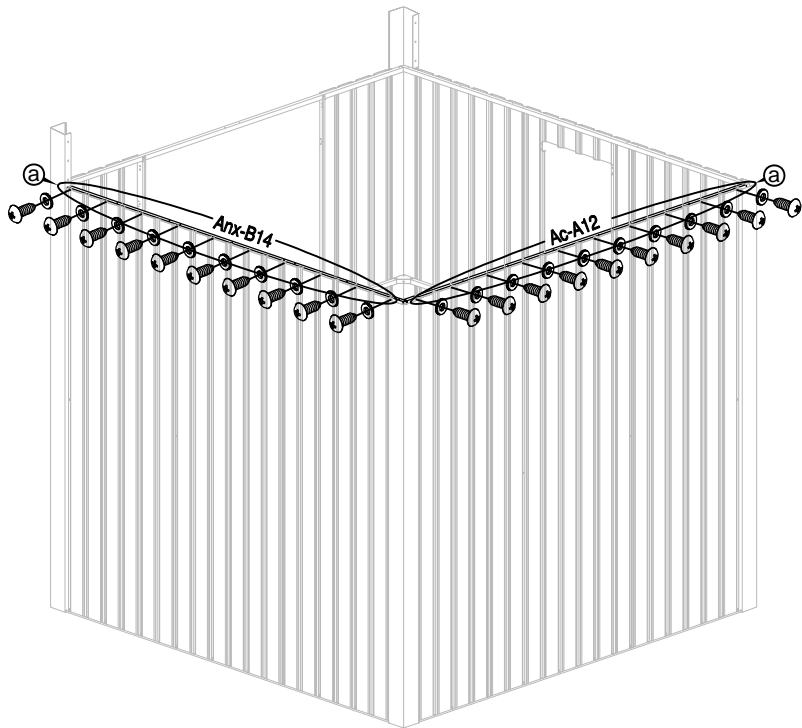
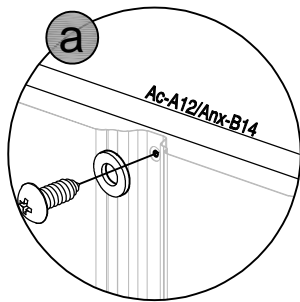
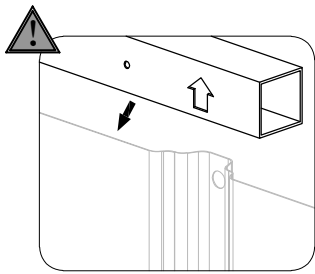

20	 Ab-4 x4	 Anx-B41 x12	
----	--	--	--

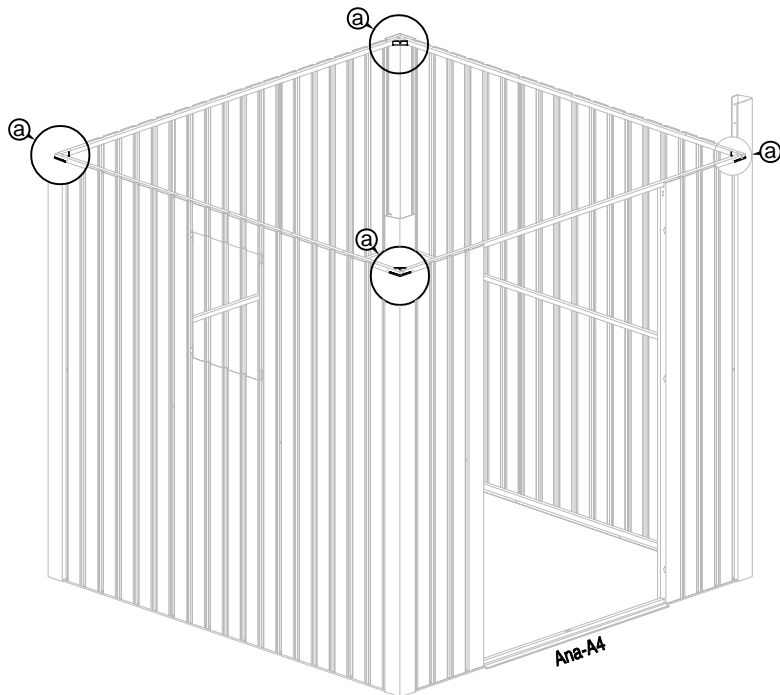
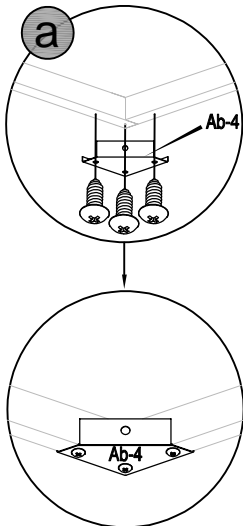

21



Ana-A17 x1



Anx-A44 x4

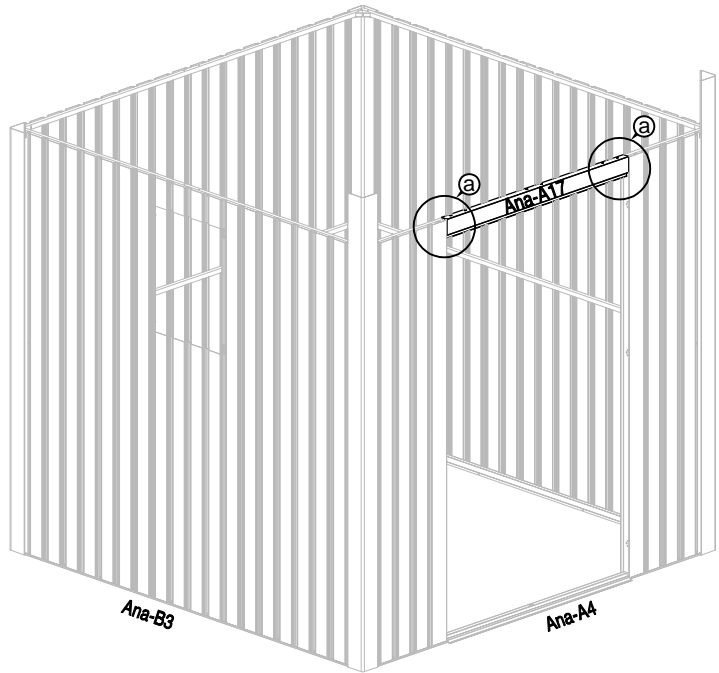
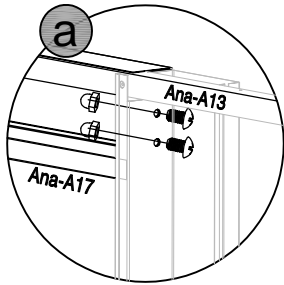
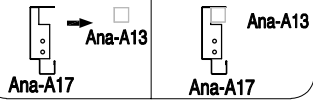

22



Ana-A18 x1







Ac-A18 x1

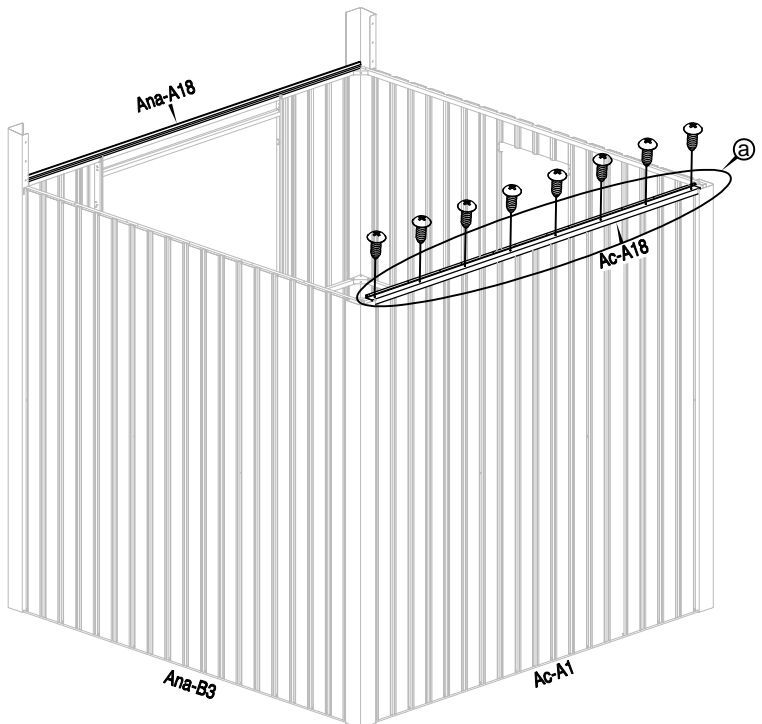
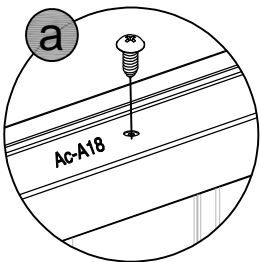
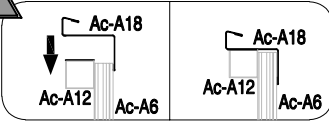

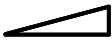



Anx-B41 x8

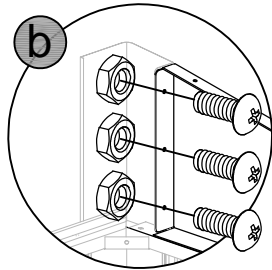
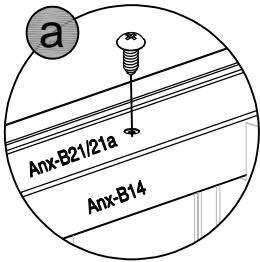
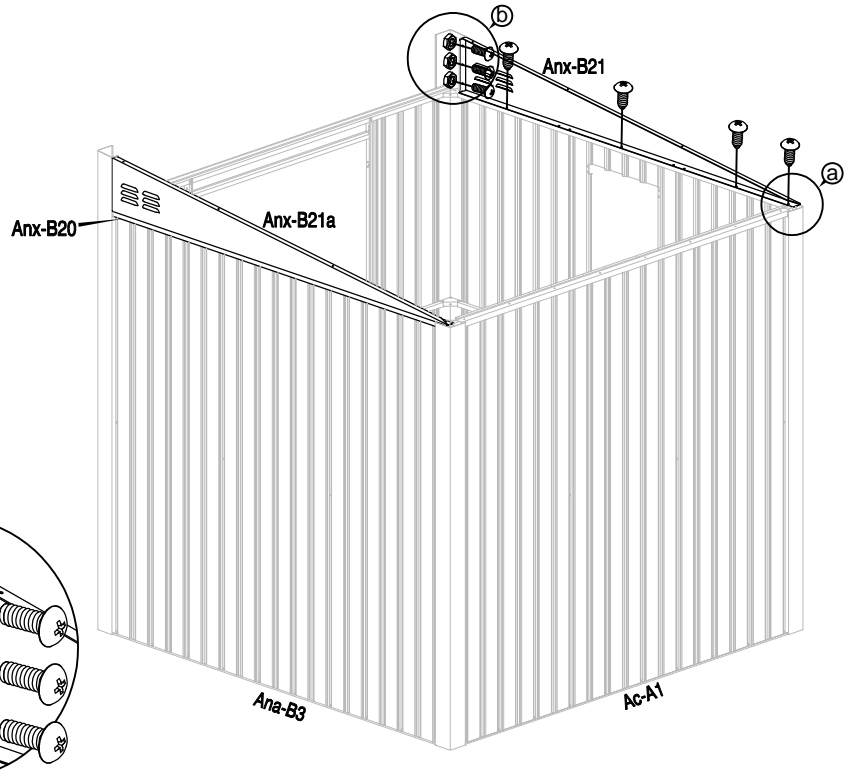
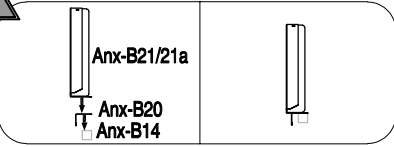
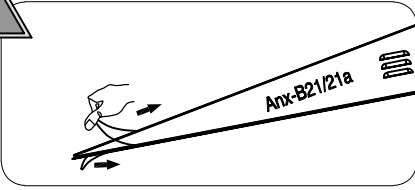

23	 Anx-B21 x1	 Anx-B21a x1	 Anx-B20 x2	 Anx-B41 x8	 Anx-B46 x6	
----	---	--	---	--	---	--



24	 Anx-B22 x2	 Anx-B22a x2	 Ana-A22b x1	 Ana-A22a x2	 Anx-B41 x14	
----	---	--	--	--	--	--

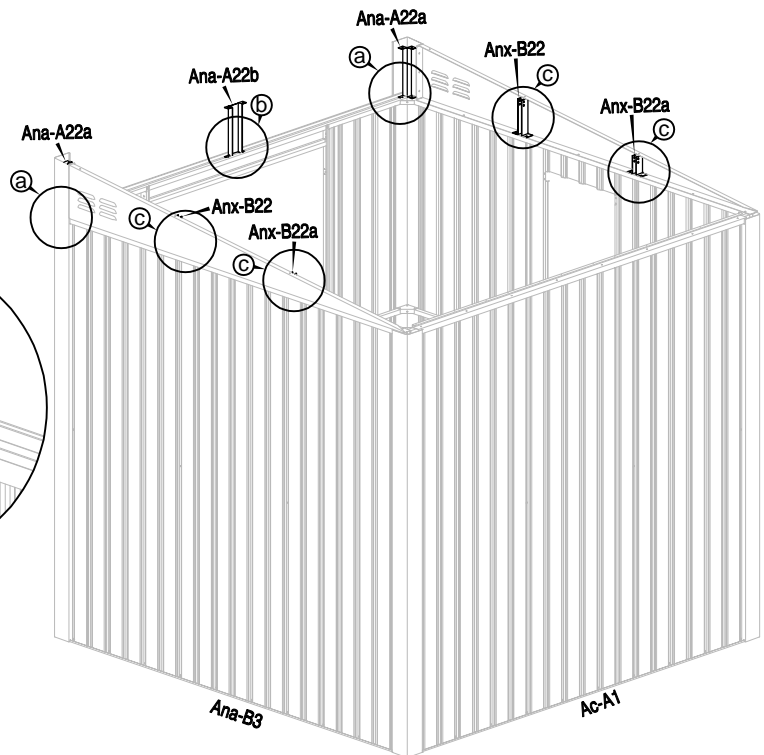
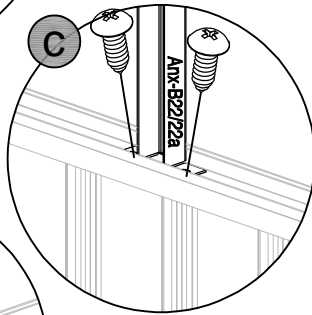
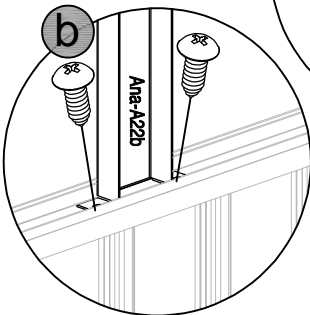
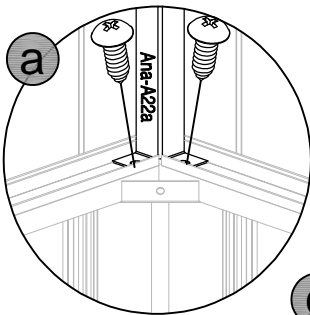

25



Ana-A36 x1

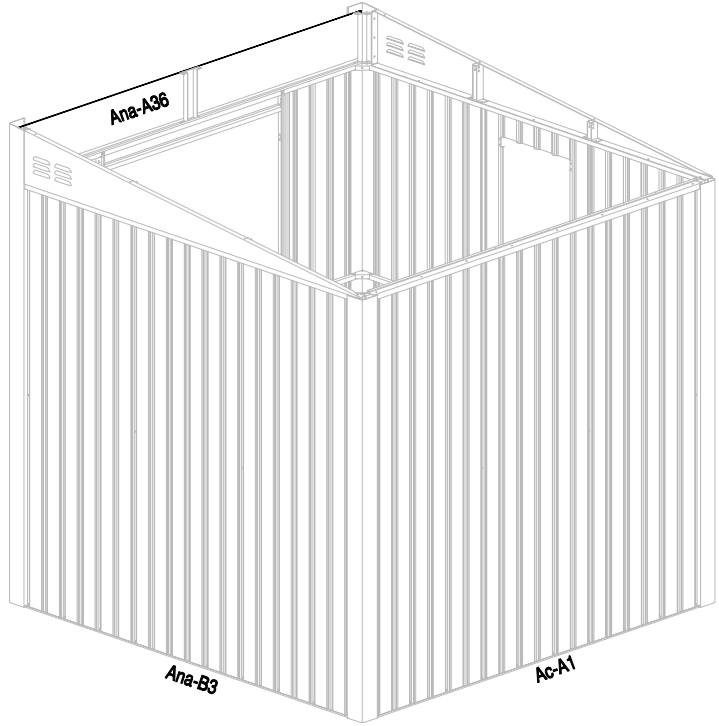
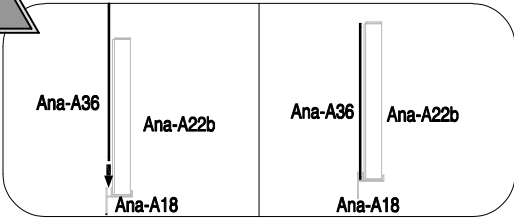
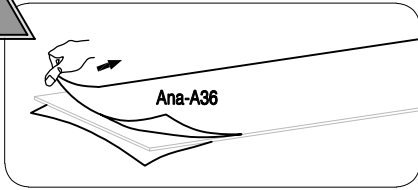

26



Anx-B23 x1



Ana-A18 x1



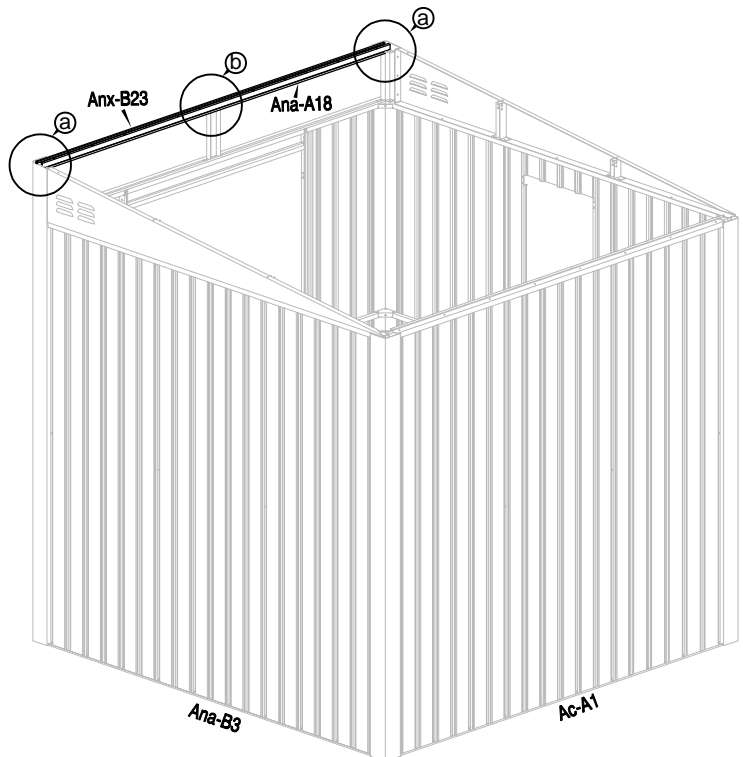
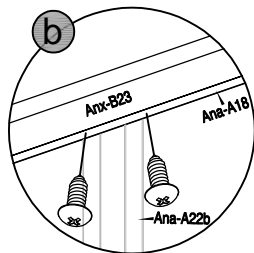
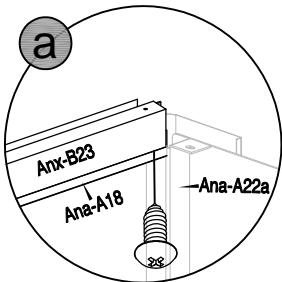
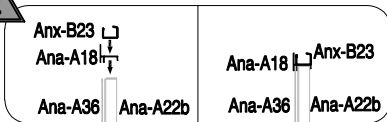

Anx-B41 x4



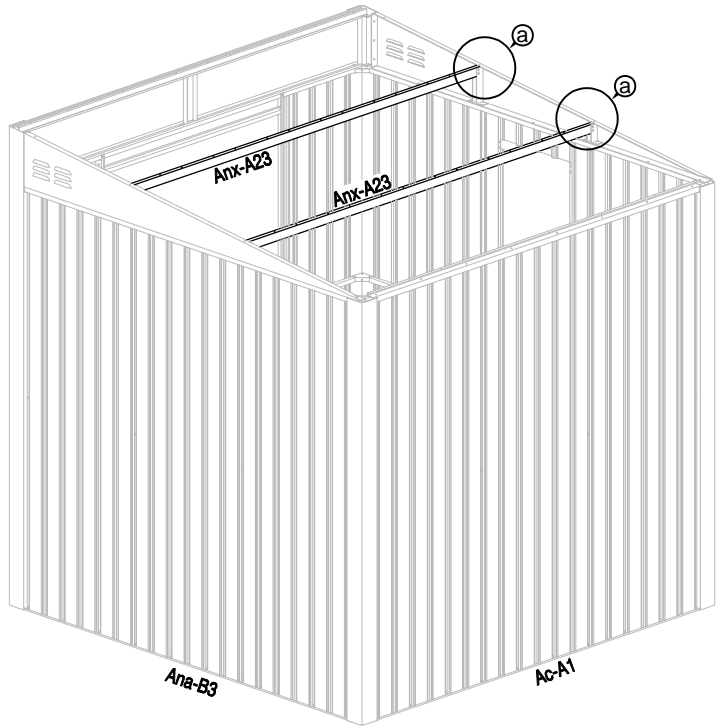
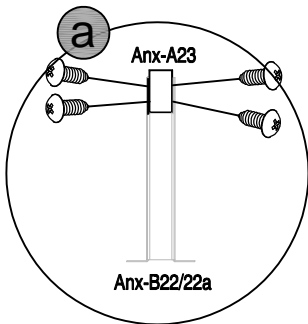
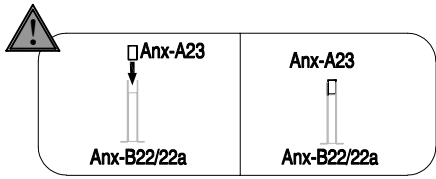

27	 Anx-A23 x2	 Anx-B41 x16	
----	---	--	--



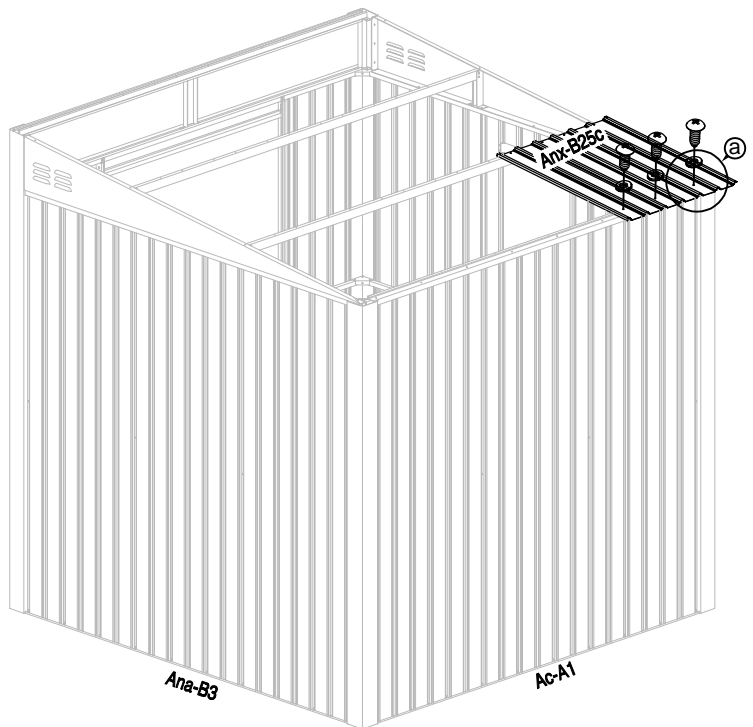
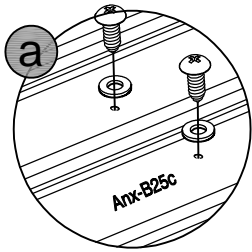

28	 Anx-B25c x1	 Anx-B41 x3	 Anx-B40 x3	
----	--	---	---	--

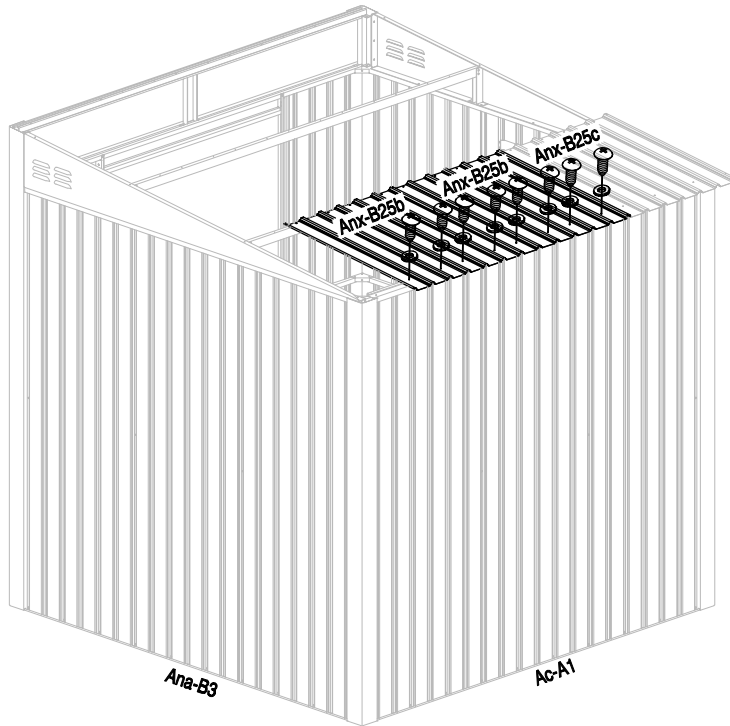
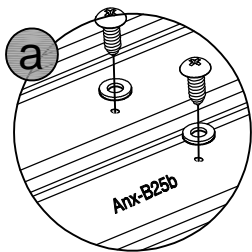
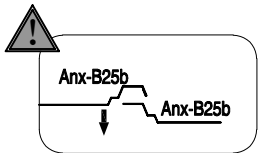
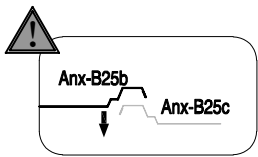

29	 Anx-B25b x2	 Anx-B41 x8	 Anx-B40 x8	
----	--	---	---	--



30	 Anx-B24a x1	 Anx-B41 x1	 Anx-B40 x1	
----	--	---	---	--

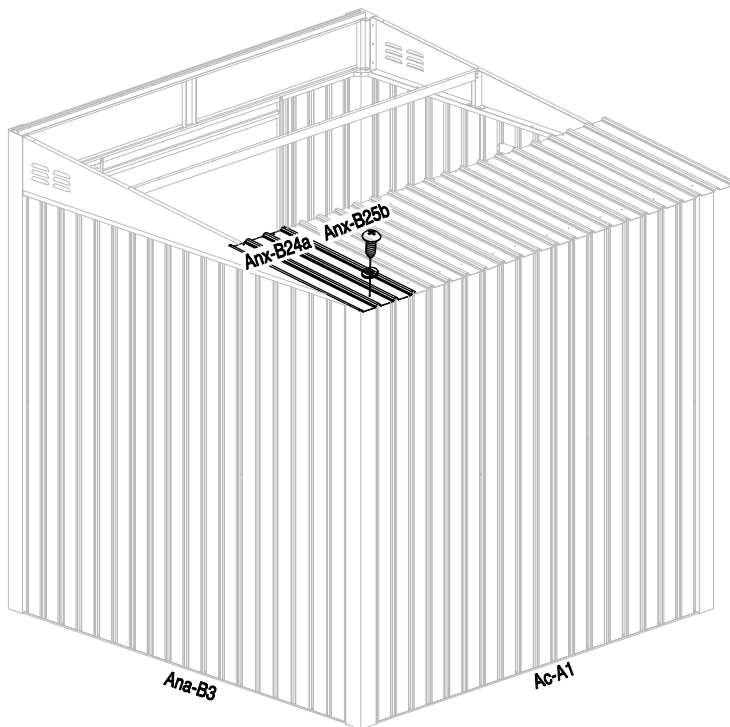
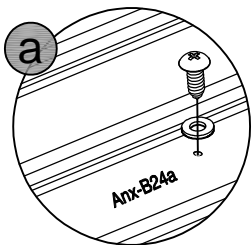
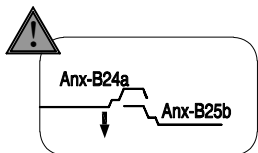

31

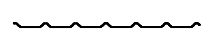

Anx-B25a x1



Anx-B41 x11



Anx-B40 x12



Anx-B46 x1

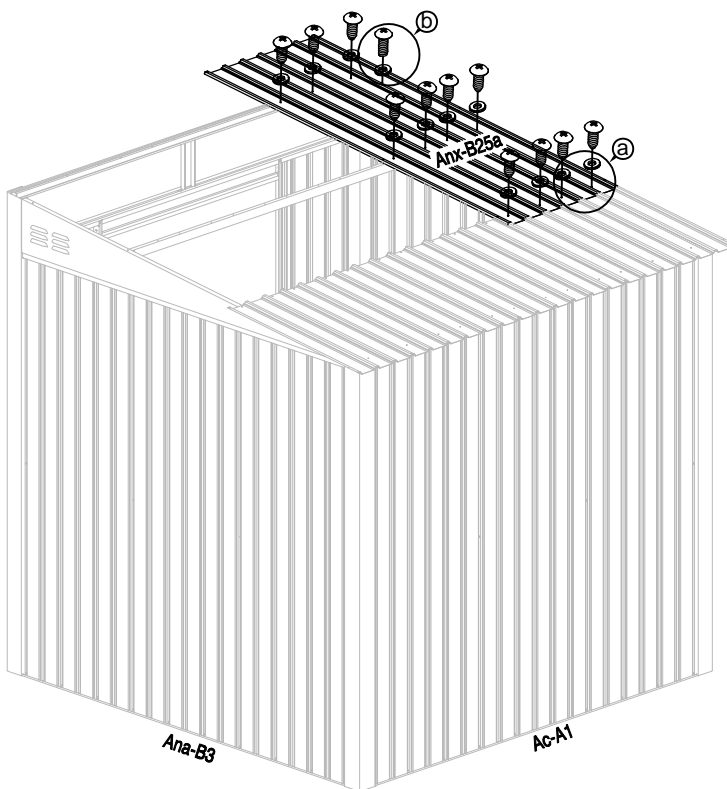
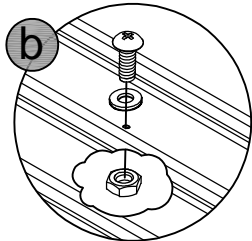
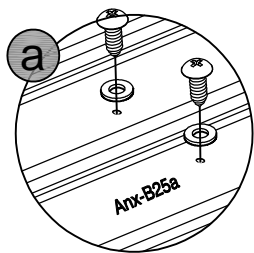

32



Anx-B25 x2



Anx-B41 x26







Anx-B40 x28

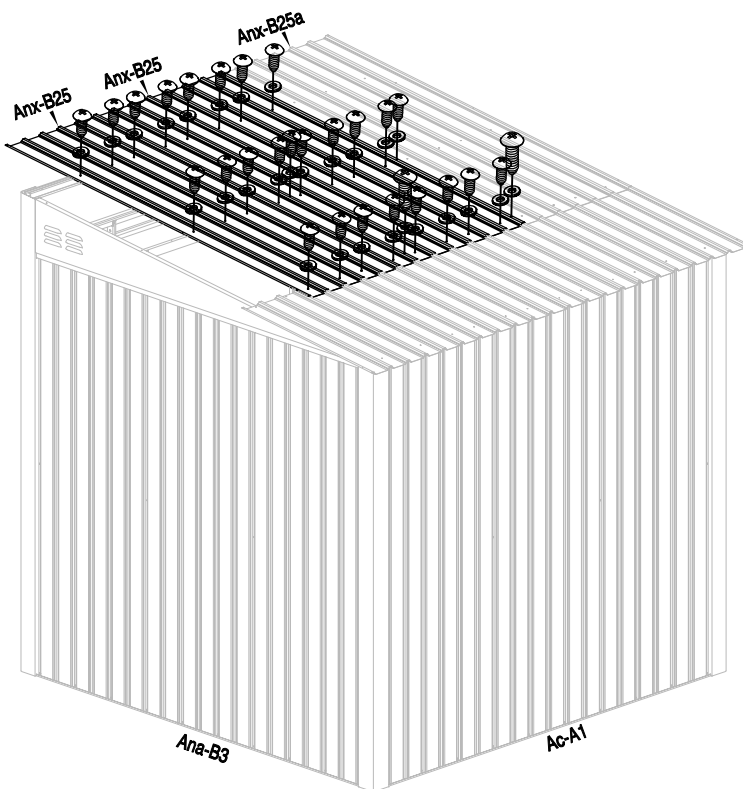
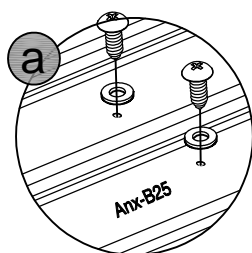
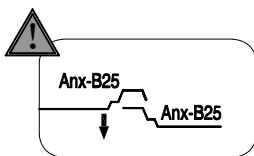
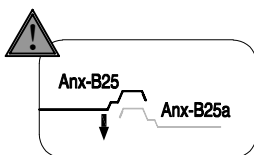







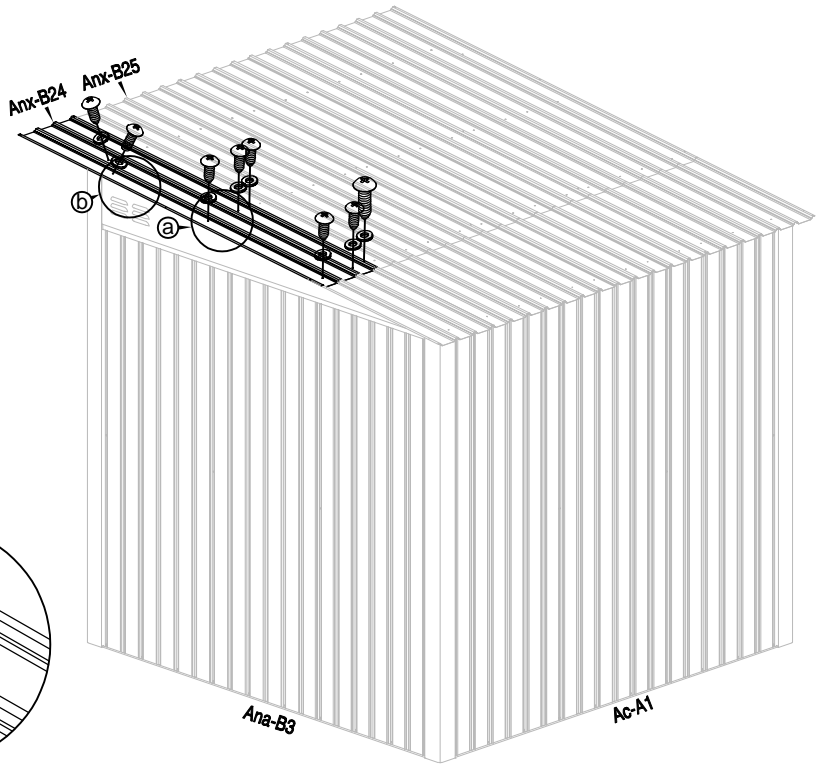
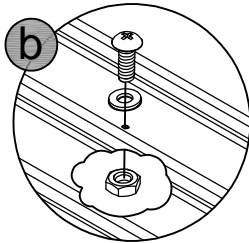
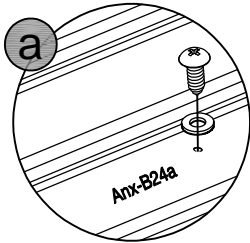
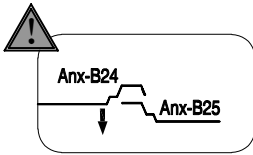

Anx-B47 x2







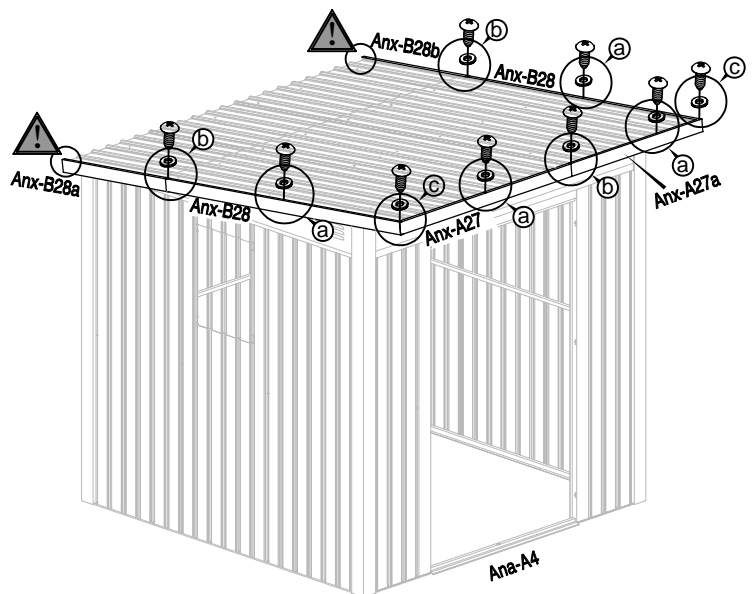
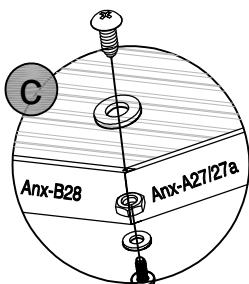
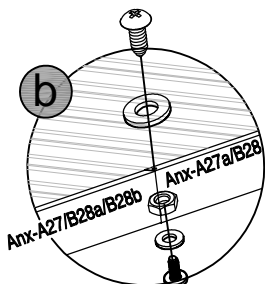
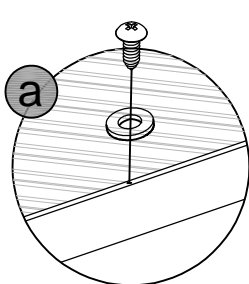
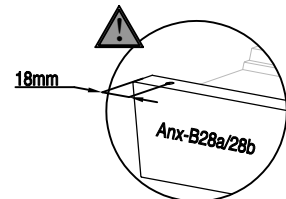
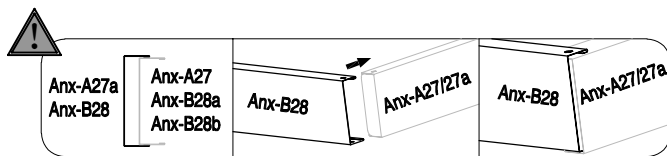

33	 Anx-B24 x1	 Anx-B41 x6	 Anx-B40 x8	 Anx-B46 x1	 Anx-B47 x1	
----	---	---	---	--	---	--



34	 Anx-A27 x1	 Anx-A27a x1	 Anx-B28 x2	 Anx-B28a x1	 Anx-B28b x1	 Anx-B41 x9	 Anx-B40 x14	 Anx-B46 x5
----	---	--	---	--	--	---	--	---



35	 Anx-A26 x1	 Anx-A26a x1	 Anx-26 x1	 Ana-P1 x2	 Anx-B40 x4	 Anx-B46 x4
----	---	--	--	--	---	---

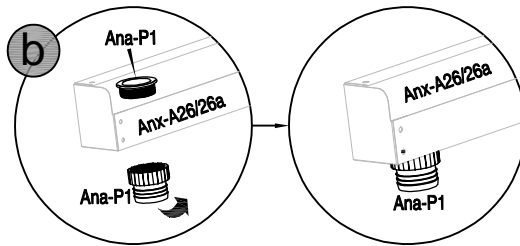
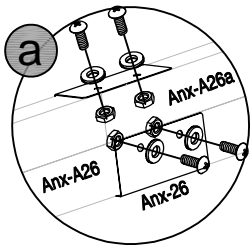
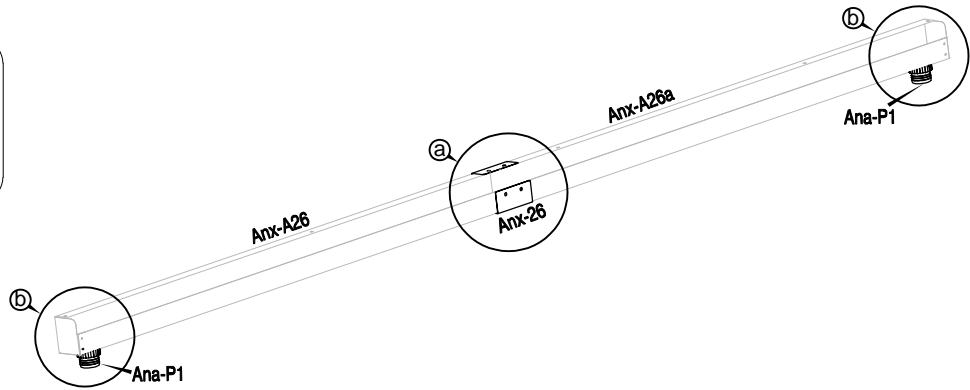
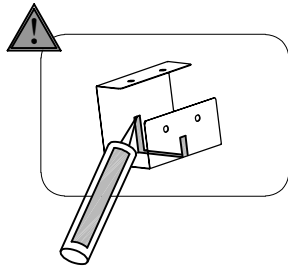

36	 Anx-B41 x7	 Anx-B40 x7	
----	---	---	--

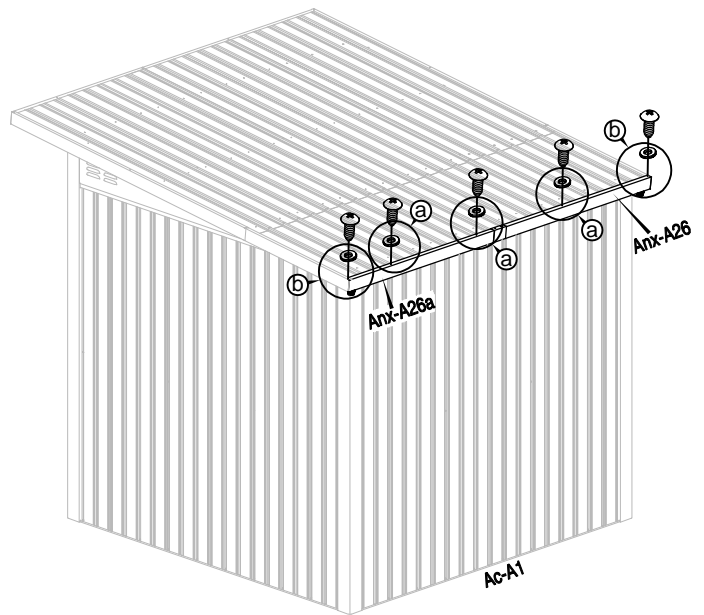
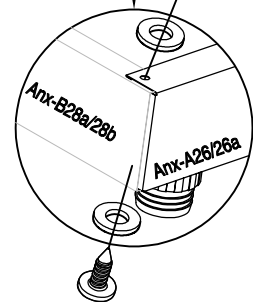
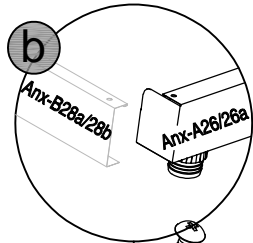
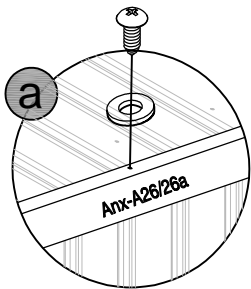
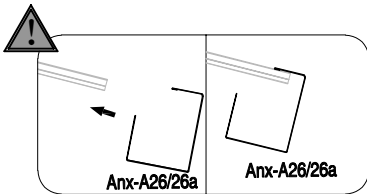

37

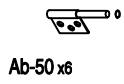

Ab-50 x6



Anx-A43 x18

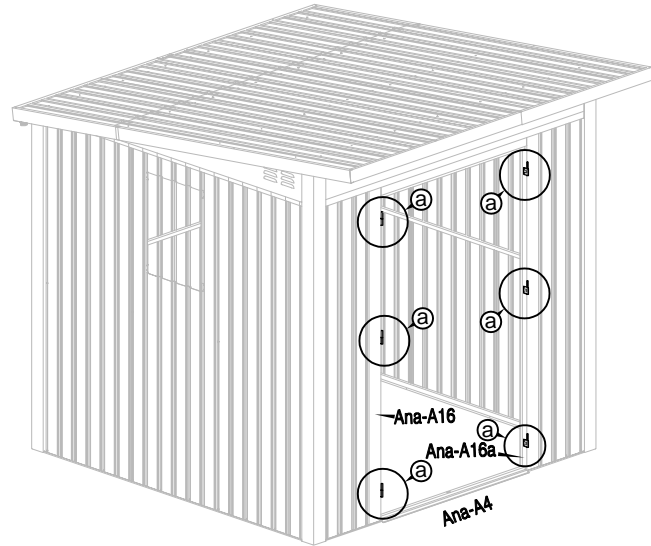
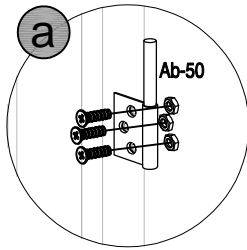

38



Ac-A29 x1



Ac-A29a x1



Ana-54 x1



Ana-55 x1



Ana-56 x1



Ana-57 x1



Ana-58 x3

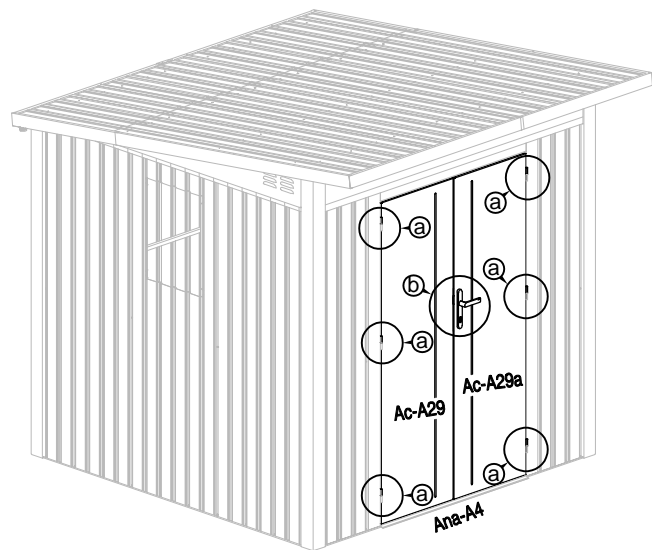
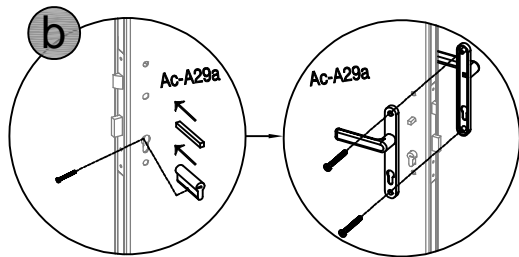
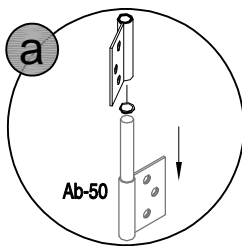

39



Ana-P6 x1



Anx-B41 x4

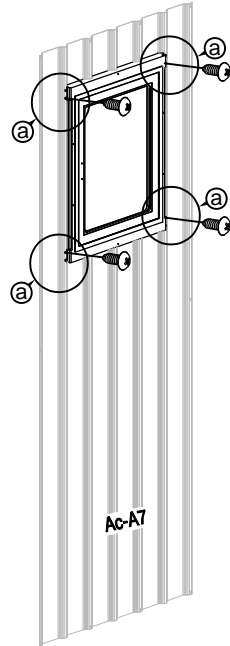
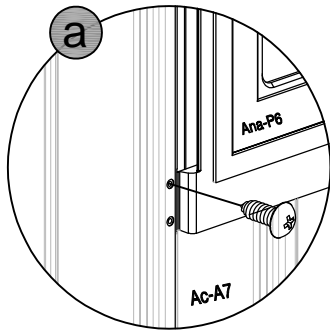
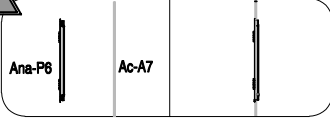

40



Ana-P7 x1



Anx-B41 x10

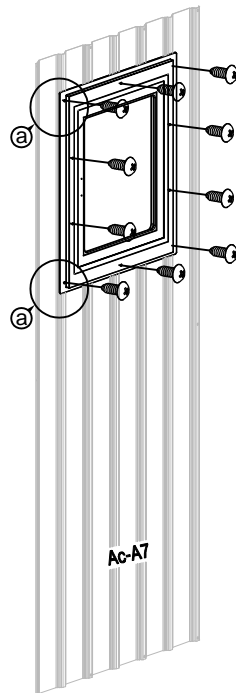
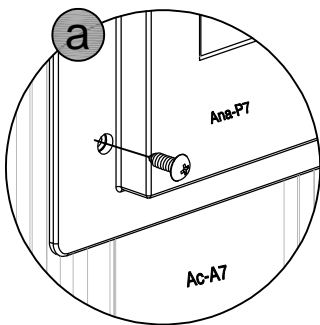
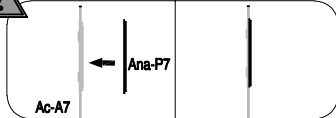

41



Ana-P8 x1



Ana-A42 x2

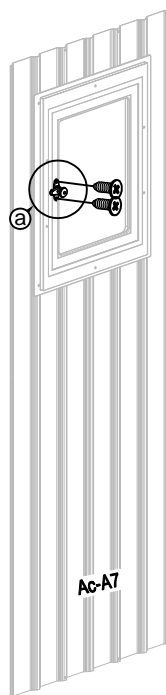
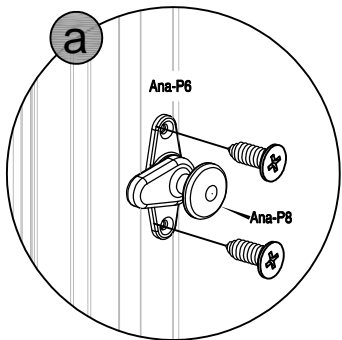

42



Anx-A37 x4.2M

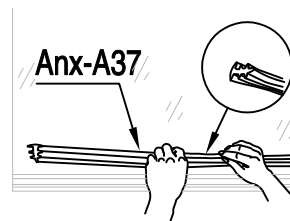
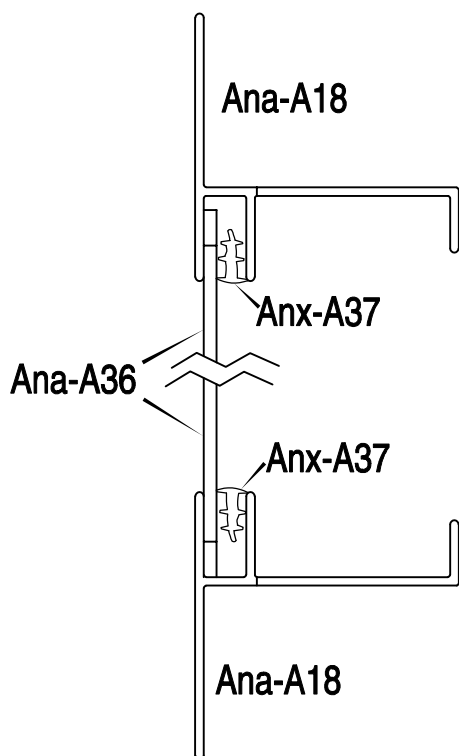

43

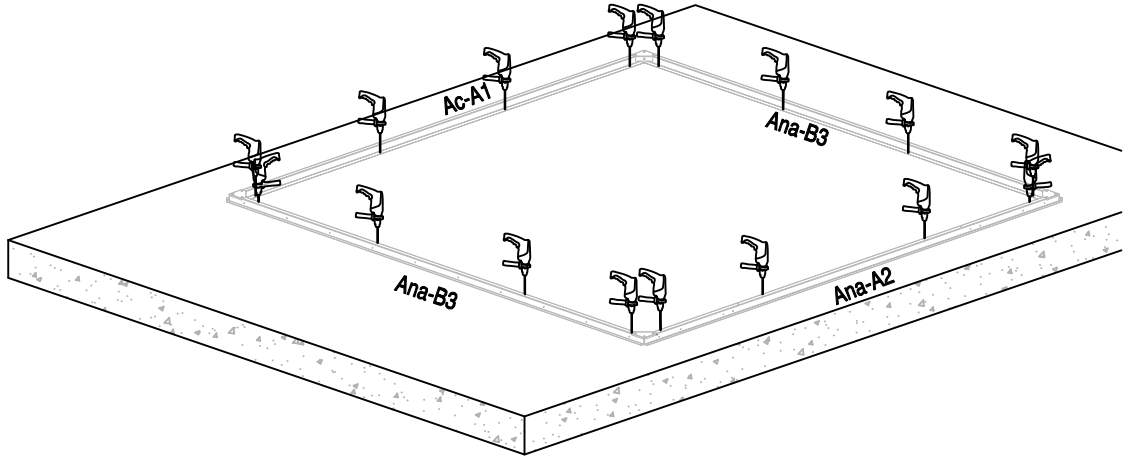
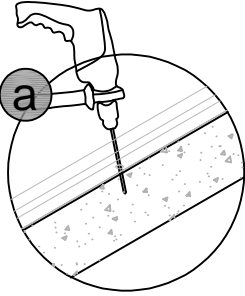
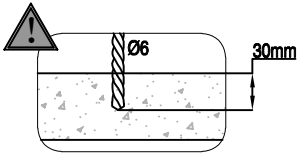
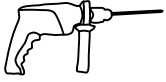

44



Anx-B45 x16

