



YardMaster

THE ORIGINAL No. 1



0112 AII NG
DG036

Please Direct Enquires to:
Yardmaster International
Cahore Rd
Draperstown
BT45 7AP
Tel: 028 796 28449
Email: info@yardmaster.co.uk

Bitte alle Anfragen an:
I.N.I.
Kaistraße 7-9
40221 Düsseldorf
Tel: 02505 / 939027 - 0
Email: service@yardmaster.co.uk

Demandes De Renseignements A:
Trigano Jardin
Service Commercial
Usine du Boulay
41170 Cormenon
Mondoubleau
Tel: (02) 54 73 55 55
Fax: 02 54 73 55 61
Email: Sav.Amca@Trigano.Fr

**Assembly
Instructions**

**Montageanweisungen
Metallgerätehäuser**

**Notice de montage
Abri de Jardin Métallique**

**Opbouwbeschrijving
Metalen Bergingen**

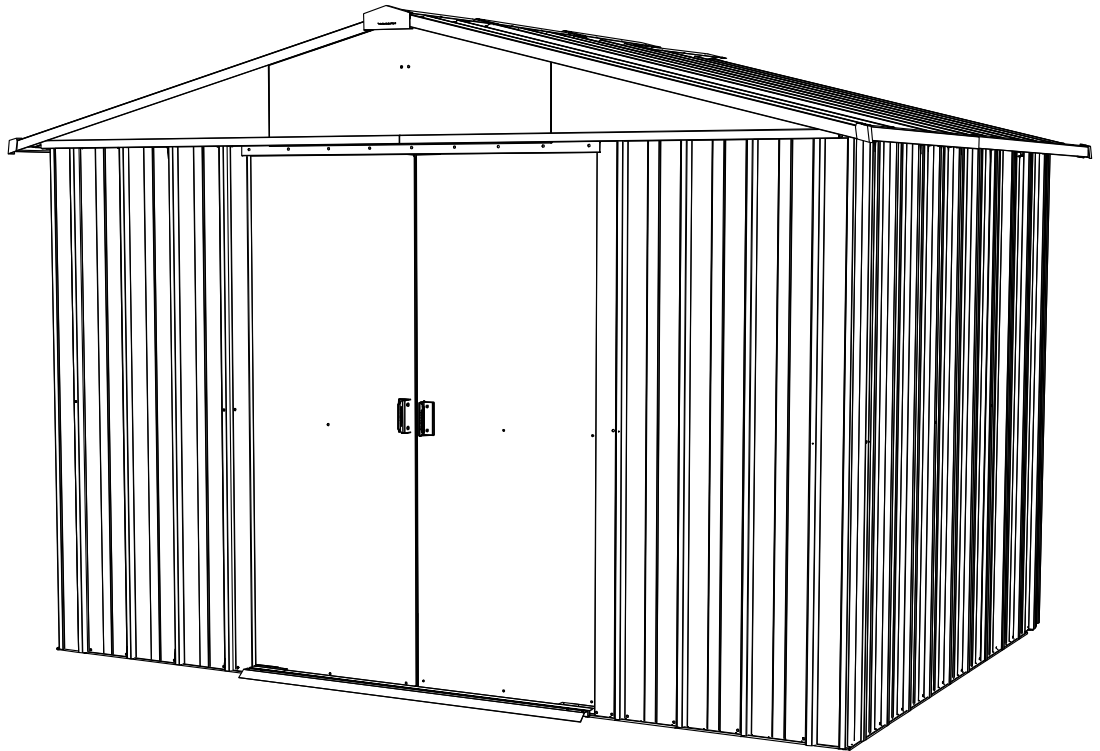

GREEN VERT GRÜN	
MODEL 1013 GEYZ	1.6m
MODEL 1013 GHZ	1.6m
MODEL 1013 AZT	1.6m
SILVER	
MODEL 1013 ZGEY	1.6m
ANTHRACITE	
MODEL 1013 AEYZ	1.6m

PARTS LIST	ONDERDELENLIJST	PART NO.	MODEL & QUANTITY	LENGTH	
PART DESCRIPTION	BESCHRIJVING VAN DE ONDERDELEN		1013	MM	
600 mm Wall Panel	600mm Wandpaneel	101	18	1600	
Corner Panel	Hoekpaneel	103	4	1600	
200mm Wall Panel	200mm Wandpaneel	102	1	1600	
Door Post	Deurstijl	106.29	2	1600	
Inter-Roof Panel	Dak-Tussenplaat	201.3	8	1520	
Narrow Inter Roof Panel	Smalle Dak-Tussenplaat	202.3	2	1520	
Left Hand Front/Right Hand Rear Roof Panel	Dakplaat Linksvoor/Rechtsachter	203.29	2	1520	
Right Hand Front/Left Hand Rear Roof Panel	Dakplaat Rechtsvoor/Linksachter	204.29	2	1520	
Translucent Roof Panel	Doorzic	205.3	2	1520	
Gable Left Hand Front/Right Hand Rear	Geveltop-Linksvoor/Rechtsachter	301	2	920	
Gable Right Hand Front/Left Hand Rear	Geveltop- Rechtsvoor/Linksachter	302	2	920	
Centre Gables	Geveltoppen-Midden	305.3	2	995	
Base Rail	Funderingsrail	401.14	1	1233	
Base Rail	Funderingsrail	401.2	1	1833	
Base Rail	Funderingsrail	401.22	4	2033	
Side Brace	Zijklamp	402.15	2	1365	
Side Brace	Zijklamp	402.2	2	1765	
Side Brace	Zijklamp	402.22	2	1965	
Side Brace Splice	Zijklamp Verbinding	402.89	3	370	
Front Brace	Voorklamp	403.3EA	2	765	
Corner Gusset	Hoekinzetstuk	406	8	86	
Corner Gusset Stiffner	Versterking Van Hoekinzetstuk	407	2	150	
Front Anchor Bracket	Verankering Steun	407EA	4	69	
Left/Right Door Guide	Deurgeleider links/Rechtsbuiten	408409.3EA	2	933	
Side Beam	Zijbalk	501.19	4	1983	
Roof Beam	Dakbalk	502.22	12	2034	
Ridge Cover	Nokplaat	503.02	4	615	
Ridge Cover	Nokplaat	503.03	1	415	
Ridge Cover	Nokplaat	503.07	1	490	
Ridge Cover	Nokplaat	503.08	1	690	
Gutter Angle	Regengoot	504.01	8	1015	
Left Hand Roof Beam Gusset	Linkersteunplaat Nokbalk	505	2	145	
Right Hand Roof Beam Gusset	Rechtersteunplaat Nokbalk	506	2	145	
Roof Beam Support	Nokbalk Steun	506.3	4	230	
Ridge Cover Cap	Nokplaat Eindstuk	507	2	160	
Left Hand Gutter Angle Cap	Eindkap	5081	2	45	
Right Hand Gutter Angle Cap	Eindkap	5091	2	45	
Left Hand Door	Linkerdeur	601.29	1	1593	
Right Hand Door	Rechterdeur	602.29	1	1593	
Door Track	Deurrail	603.63	2	1390	
Gable Brace	Geveltop-Klamp	603.18	4	1395	
Door Slider	Deurrolletje	6071	4	45	
Door Brace	Deurklamp	620.3	6	640	
Door Saddle	Deurslede	608.3EA	1	1226	
Door Handle	Deurhendel	609	2	100	
Door Pelmet	Verbindung Teil	615.02	1	1264	

LISTE DE PIECES	TEILE-LISTE	PART NO.	MODEL & QUANTITY	LENGTH	
DESCRIPTION DE LA PIECE	TEILE-BEZEICHNUNG		1013	MM	
Panneau Mural 600mm	600mm Wandplatten	101	18	1600	
Panneau D'angle	Eckplatten	103	4	1600	
Panneau Mural 200mm	200mm Wandplatten	102	1	1600	
Montant De Porte	Türpfosten	106.29	2	1600	
Panneau Toit (Milieu)	Dach-Zwischenplatten	201.3	8	1520	
Panneau Toit Étroit	Schmale Dach-Zwischenplatten	202.3	2	1520	
Panneau Toit Avant Gauche/Arrière Droite	Linke Vordere Bzw. Hintere Rechte Dachplatte	203.29	2	1520	
Panneau Toit Avant Droite/Arrière Gauche	Rechte Vordere Bzw. Hintere Linke Dachplatte	204.29	2	1520	
Fenêtre Toit	Dach-Oberlicht	205	2	1520	
Pignon-Avant Gauche/Arrière Droite	Giebel-Vorne Links Bzw. Hinten Rechts	301	2	920	
Pignon-Avant Droite/Arrière Gauche	Giebel-Vorne Rechts Bzw. Hinten Links	302	2	920	
Pignons Centraux	Mittel-Giebel	305.3	2	995	
Rail Base	Grundleiste	401.14	1	1233	
Rail Base	Grundleiste	401.2	1	1833	
Rail Base	Grundleiste	401.22	4	2033	
Cornières Latéral	Seitenstütze	402.15	2	1365	
Cornières Latéral	Seitenstütze	402.2	2	1765	
Cornières Latéral	Seitenstütze	402.22	2	1965	
Cornières Latéral	Seitenstütze Verbindung	402.89	3	370	
Cornières Avant	Vorderstütze	403.3EA	2	765	
Renfort D'angle Arrière	Hintere Eckenwinkel	406	8	86	
Kit D'ancrage	Eckenwinkelversteifung	407	2	150	
Bride d'angle devant	Eckenwinkelversteifungen	407EA	4	69	
Guide De Porte Gauche/Droite	Linke/Rechte äußere Türführung	408409.3EA	2	933	
Poutre Latérale	Seitenträger	501.19	4	1983	
Poutre Toit	Dachträger	502.22	12	2034	
Faîtière	Firstverkleidung	503.02	4	615	
Faîtière	Firstverkleidung	503.03	1	415	
Faîtière	Firstverkleidung	503.07	1	490	
Faîtière	Firstverkleidung	503.08	1	690	
Gouttière D'angle	Dachrinnen	504.01	8	1015	
Gousset De Poutre Faîtière Gauche	Linke Firsträgerwinkel	505	2	145	
Gousset De Poutre Faîtière Droite	Rechte Firsträgerwinkel	506	2	145	
Soutien De Poutre Toit	Dachtragbalken	506.3	4	230	
Cache Plastique Toiture	Firstverkleidungskappe	507	2	160	
Embout D'Extrémité De Gouttière Gauche	Linke Dachrinnen-Endkappen	5081	2	45	
Embout D'Extrémité De Gouttière Droite	Rechte Dachrinnen-Endkappen	5091	2	45	
Porte Gauche	Linke Tür	601.29	1	1593	
Porte Droite	Rechte tür	602.29	1	1593	
Glissière De Porte	Türschienen	603.63	2	1390	
Glissière De Pignon	Giebel-Vorne Balken	603.18	4	1395	
Coulissière De Porte	Türrollen & Befestigungsteil	6071	4	45	
Porte Renforcee	Tür Balken	620.3	6	640	
Bride De Porte	Türschwelle	608.3EA	1	1226	
Poignée De Porte	Türgriff	609	2	100	
Pièce de Junction	Verbindung Teil	61502	1	1264	

WALL PANEL PANNEAU MURAL WANDPLATTEN WANDPANEEL

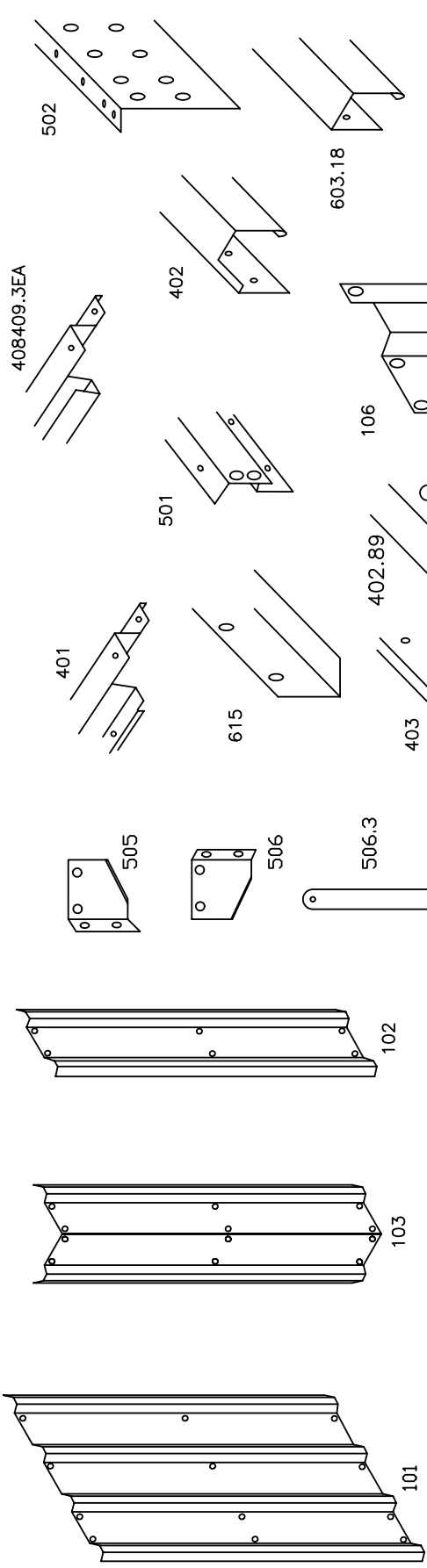

ROOF PANEL PANNEAU TOIT DACHPLATTE DAKPLAAT

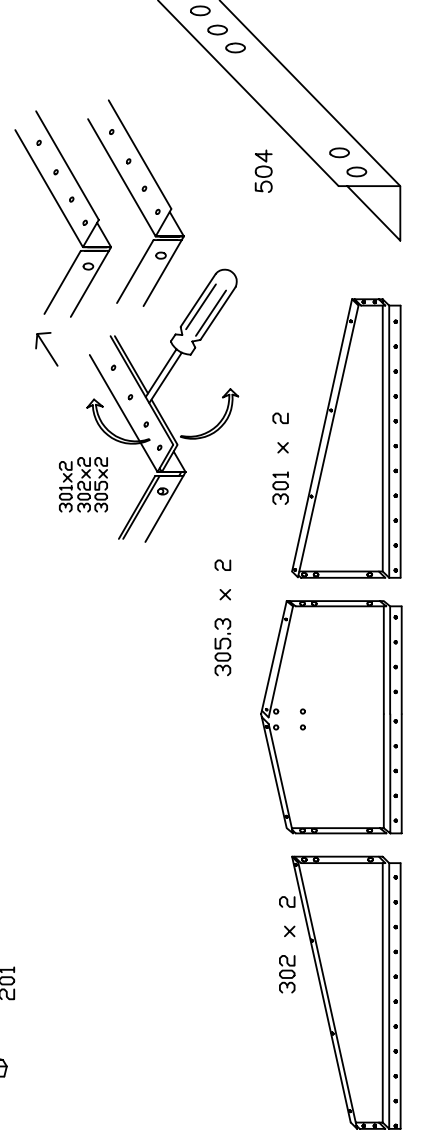
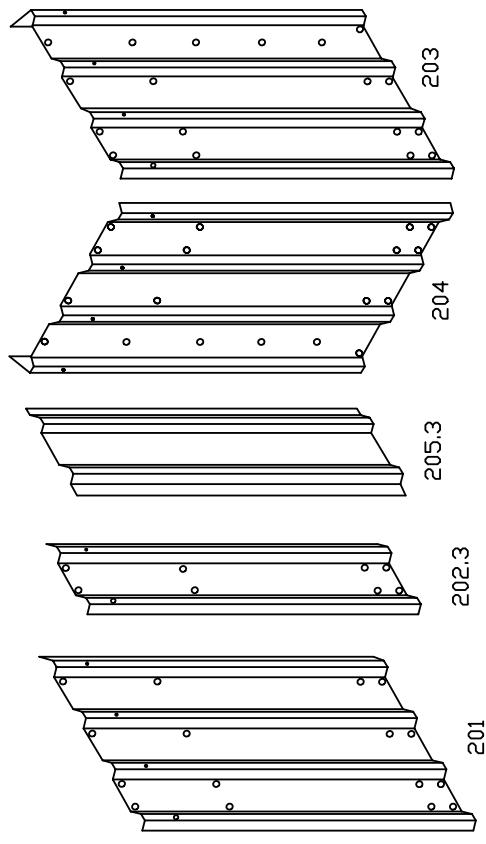

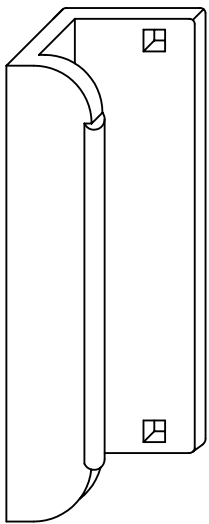

609 x 2

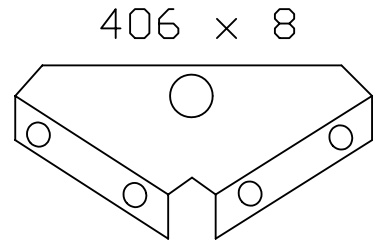
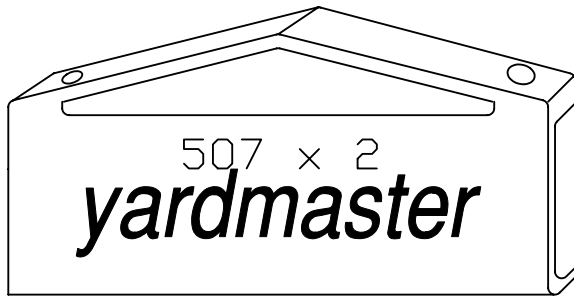

406 x 8

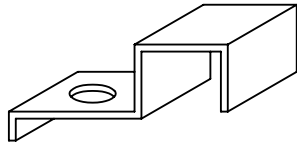

407EA x 4

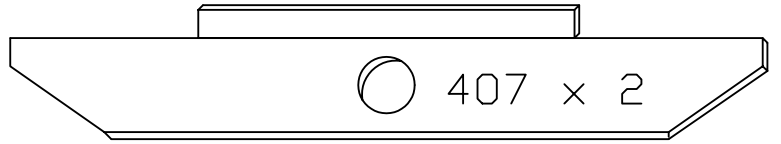

407 x 2

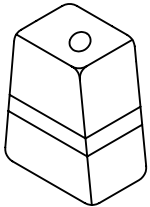

5081 x 2

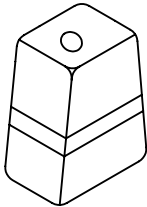

5091 x 2

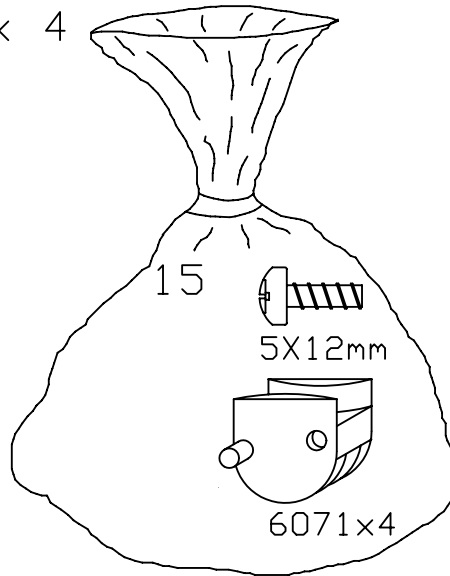

15

5X12mm

6071x4

M5X12mm

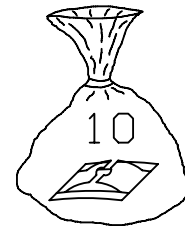
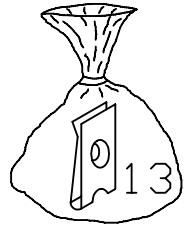
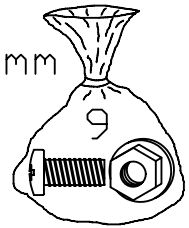

12x4mm



11x4mm

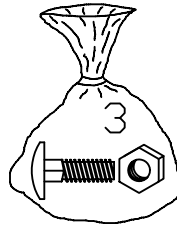
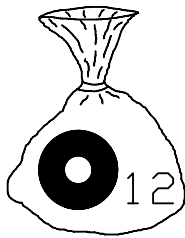

12X5mm X 4

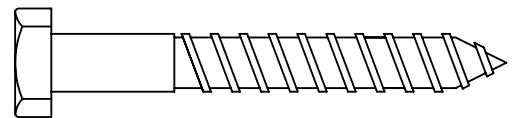

M8X50mm X 4

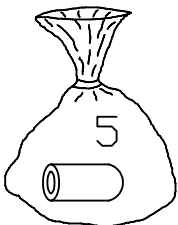

8X9mm

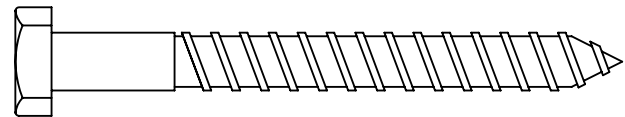
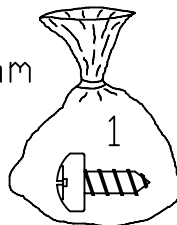

M8X70mm X 2

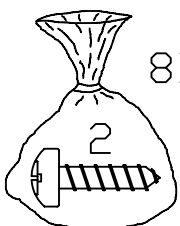

8X12mm

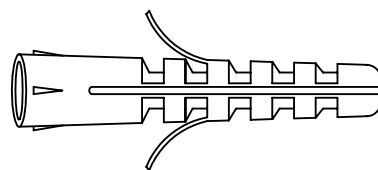

M10X50mm X 6

M8X19mm X 6

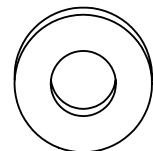

ASSEMBLY INSTRUCTIONS MODEL 1013.

Before starting, read through the assembly instructions carefully. Check thoroughly all the parts you have received against the parts list (page 1) and the diagram (page 3,4). Ensure that no parts are damaged.

THINGS TO REMEMBER !

- 1. WEATHER WARNING ! DO NOT ERECT YOUR BUILDING ON A WINDY DAY. ANY BUILDING LEFT PARTIALLY CONSTRUCTED MAY BE SERIOUSLY DAMAGED FIG1.**
- 2. ALL ASSEMBLY OPERATIONS MUST TAKE PLACE ON A COMPLETELY LEVEL SURFACE FIG 1.**
- 3. UNLESS OTHERWISE STATED SCREWS AND WASHERS (BAGS 1 AND 12) MUST BE USED IN ALL ASSEMBLY OPERATIONS.**
- 4. THE MODEL 1013 SHED COMPRISES SOME LONG COMPONENTS. FOR EASE OF CONSTRUCTION IT IS ADVISABLE TO HAVE THE ASSISTANCE OF ANOTHER PERSON.**
- 5. IT IS RECOMMENDED THAT YOU WEAR GLOVES WHEN ASSEMBLING THIS PRODUCT**
- 6. THE SHED SHOULD BE SECURELY ANCHORED TO A FIRM LEVEL BASE E.G. CONCRETE, PAVING SLABS WOOD ETC FOR CONCRETE BASE SEE BELOW.**

SITE PREPARATION CONCRETE.

1. Concrete should be laid a minimum of 75mm thick and at least 100mm greater than the overall size of the metal base frame at approx. 25mm above ground level. A sheet of heavy duty polythene placed under the base area will help prevent dampness rising from the ground into the shed. For concrete base measurements see fig. 2.

NOTICE DE MONTAGE 1013.

Avant de commencer à lire attentivement la notice de montage, vérifiez précisément si vous avez bien reçu toutes les pièces énoncées sur la liste page 2, ainsi que sur le schéma page 3&4. Assurez vous qu'aucune pièce n'a été endommagée.

N'OUBLIEZ PAS !

- 1. TEMPÊTE DE VENT: NE JAMAIS MONTER VOTRE ABRI PAR GRAND VENT. NE PAS LAISSER UN ABRI PARTIELLEMENT MONTÉ, LES PIÈCES POUVANT ÊTRE ENDOMMAGÉES (FIG. 1).**
- 2. L'ABRI MODÈLE 1013 COMPREND QUELQUES PIÈCES LONGUES POUR. POUR**

FACILITER LA CONSTRUCTION NOUS RECOMMANDONS L'AIDE D'UNE AUTRE PERSONNE.

- 3. TOUTES LES OPÉRATIONS DE MONTAGE DOIVENT ÊTRE RÉALISÉES SUR UNE SURFACE PLANE (FIG 1).**
- 4. UTILISER SUR TOUTES LES VIS À MÉTAUX D'ASSEMBLAGE (SAC NO 1) LES RONDELLES D'ÉTANCHÉITÉ (SAC NO 12).**
- 5. IL EST RECOMMANDÉ DE PORTER DES GANTS DE TRAVAIL PENDANT LE MONTAGE.**

6. L'ABRI DOIT ÊTRE FIXE AU SOL SUR UNE SURFACE PLANE, PAR EXEMPLE, BETON, DALLES EN BETON, BOIS ETC. POUR UNE SURFACE DE BETON, VOIR CI-DESSUS.

PRÉPARATION DE LA DALLE:

1. Le béton doit être coulé sur une épaisseur de 75mm, et dépasser de 100mm la hauteur du profilé de base soit 25mm au dessus du niveau du sol. L'utilisation d'une toile de polythène épaisse et résistante, placée sous la base aidera à empêcher l'humidité de monter du sol dans l'abri. Pour les dimensions de la dalle en béton, vous reporter à la fig. 2.

MODELLE 1013 MONTAGEANLEITUNG

VOR BEGINN:

1. Machen Sie sich mit den Montageanweisungen vertraut.
2. Überzeugen Sie sich an Hand der Teileliste (Seite 2) und der Schaubilder (seite 3 &4), ob alles vollständig ist und die Teile nicht beschädigt sind.

WICHTIG

- 1. STELLEN SIE DAS HAUS NICHT AN EINEM STÜRMISCHEN TAG AUF. JEDES HAUS WÜRDE UNTER SOLCHEN FIG. 1. WETTERLAGE BESCHÄDIGT WORDEN.**
- 2. MAN MUß DEN GARTENSCHUPPEN AUF EINER GANZ EBENER FLÄCHE ERRICHTEN FIG. 1.**
- 3. SOFERN NICHT ANDERS ANGEZEIGT BENÜTZEN SIE DIE SCHRAUBEN UND WASSERDICHTEN FASERSCHEIBEN (BEUTEL 1 & 12) BEI ALLEN MONTAGEGÄNGEN.**
- 4. ES WIRD EMPFOHLEN, HANDSCHUHE BEI DER MONTAGE ZU TRAGEN.**
- 5. DAS MODELL 1013 BESTEHT AUS EINIGEN LANGEN TEILEN. WIR EMPFEHLEN, DAHER DAß SIE HILFE BEI DER MONTAGE BEKOMMEN.**

VORBEREITUNG DES BETONFUNDAMENTS:

Die Betonplattform soll mindestens 70-80mm stark und mindestens 100mm länger und breiter als der metall-grundrahmen sein. die plattform sollte außerdem mindestens 25mm über dem boden sein. Ein laken aus hochleistungskunststoff unter dem fundament wird dazu helfen, feuchtigkeit vorzubeugen, die von der erde in den schuppen hineindringt Fig. 2.

BOUWHANDLEIDING MODELLEN 1013

Voordat U met de bouw begint, maakt U zich dan eerst goed vertrouwd met de bouwaanwijzingen. Kruis alle ontvangen onderdelen op de onderdelenlijst (pagina 1) en diagram (pagina 3&4) aan. Controleer of de onderdelen niet zijn beschadigd.

BELANGRIJK !

- 1 MONTEER UW SCHUUR NIET OP EEN WINDERIGE DAG. IEDER GEDEELTELIJK GEMONTEERDE SCHUUR KAN DAN ERG BESCHADIGEN. (AFB 1).**
- 2 DE BOUW DIENT UITGEVOERD TE WORDEN OP EEN GEHEEL VLAKKE ONDERGROND (AFB 1).**
- 3 TENZIJ ANDERS AANGEGEVEN MOETEN BIJ HET MONTEREN SCHROEVEN EN FIBBEN (Zak 1 en 12) WORDEN GEBRUIKT.**
- 4 HET SCHUURMODEL 1013 BESTAAT UIT LANGE ONDERDELEN, DUS WORDT DE HULP VAN EEN ANDERE PERSOON VEREIST**
- 5. HET IS AAN TE RADEN HANDSCHOENEN BIJ HET MONTEREN TE DRAGEN.**

VOORBEREIDING VAN DE BOUWPLAATS VAN BETON

1 Het beton dient minimaal 75mm dik te worden gelegd. Ongeveer 25mm boven grondniveau dient het beton minstens 100mm breder te zijn dan de totale maal van het metalen funderingsraam. Afb. 2.

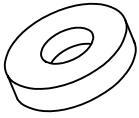
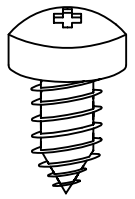

WASHERS TO BE USED ON ALL SCREWS
 VEZELRINGEN VOOR GEBRUIK ONDER ALLE SCHROEVEN
 RONDELLES POUR TOUTES LES VIS
 FASER SCHEIBEN FUR VERWENDUNG MIT ALLEN SCHRAUBEN
 ARANDELAS QUE DEBEN USARSE CON TODOS LOS TORNILLOS
 ANILHAS PARA SEREM UTILIZADAS EM TODOSMOS PARAFUSOS

FIG. 1

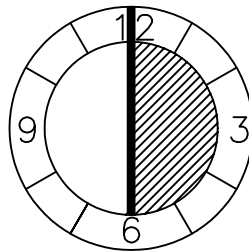
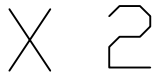
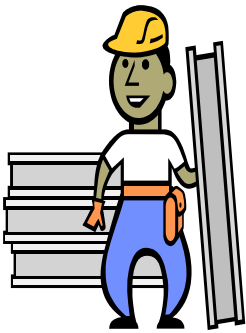
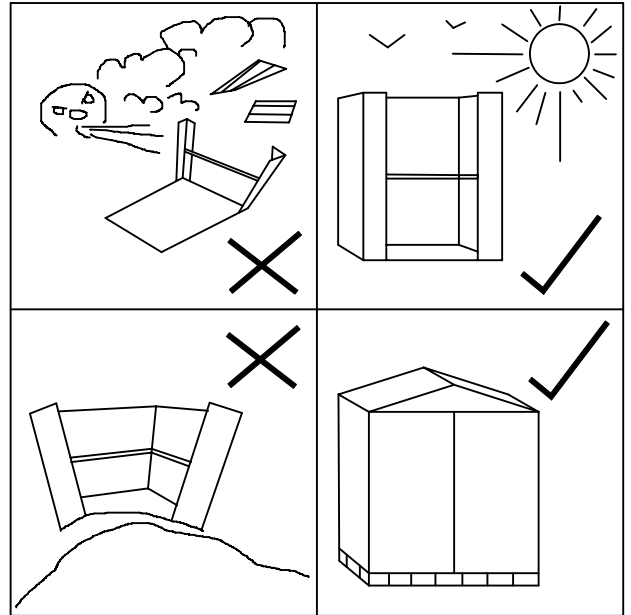
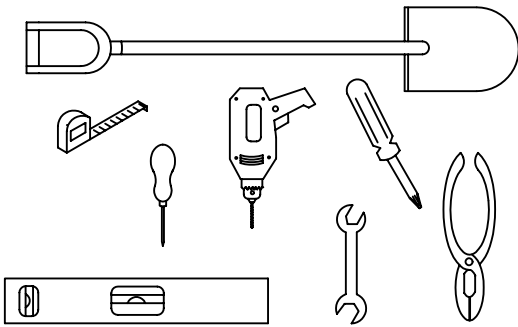
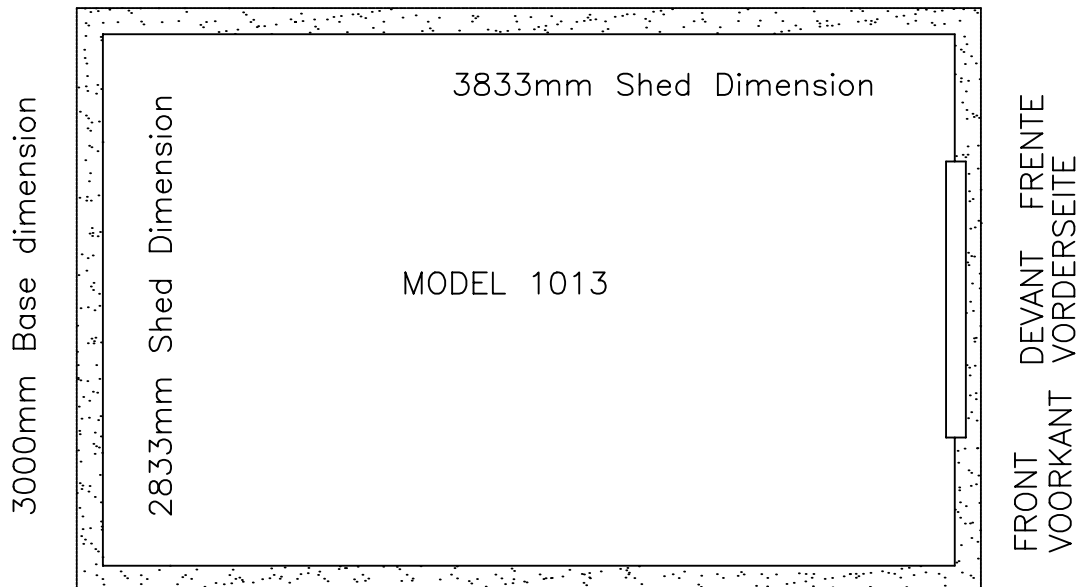
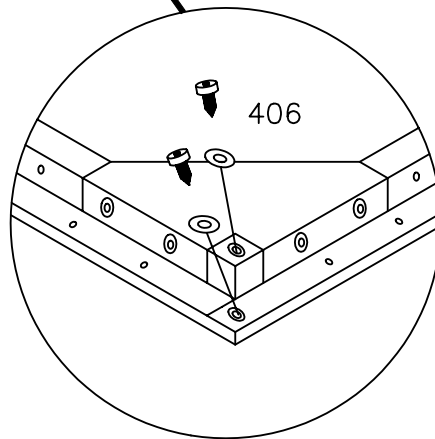
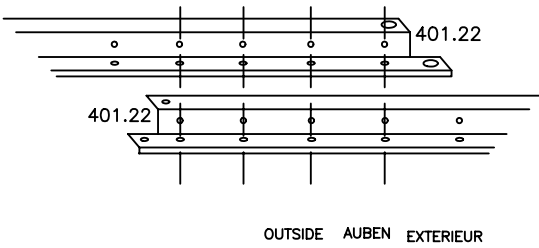
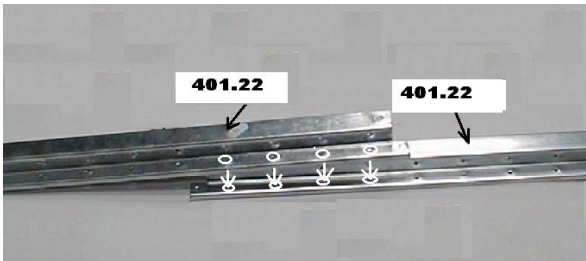
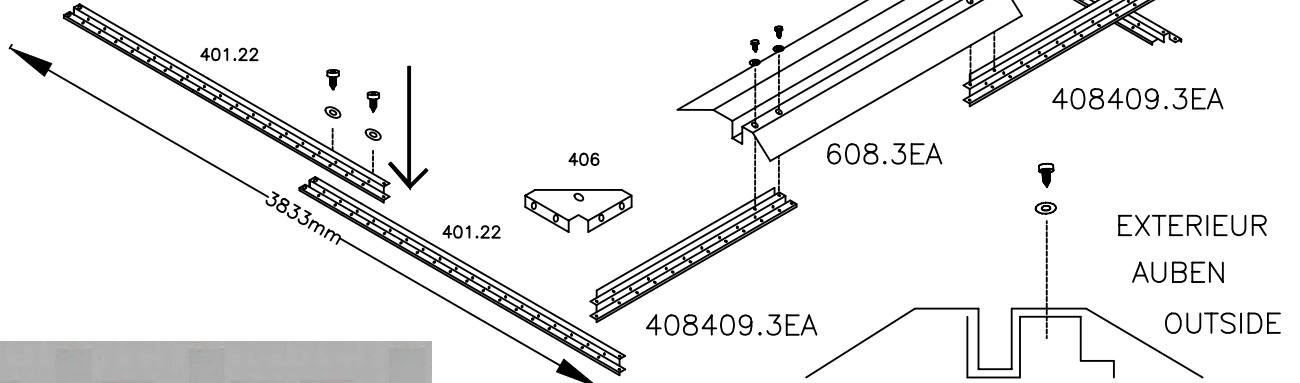
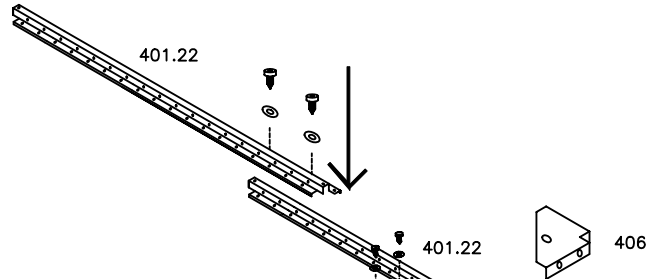
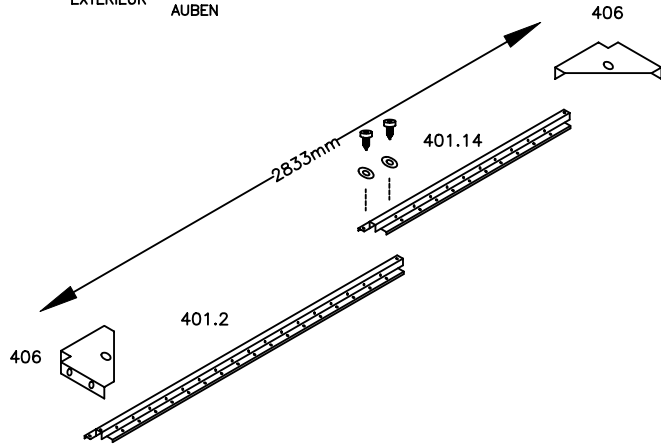
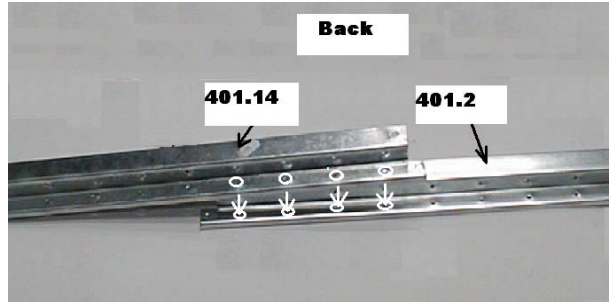
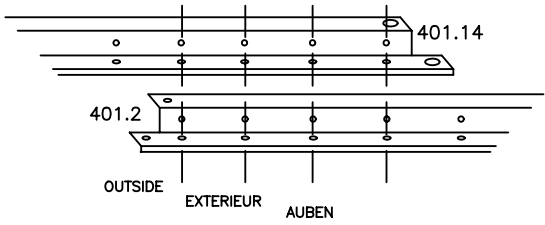

FIG. 2

3980mm Base Dimension





FRONT
VOORKANT
DEVANT
VORDERSEITE
FRENTE

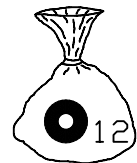
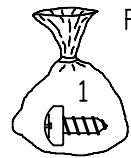

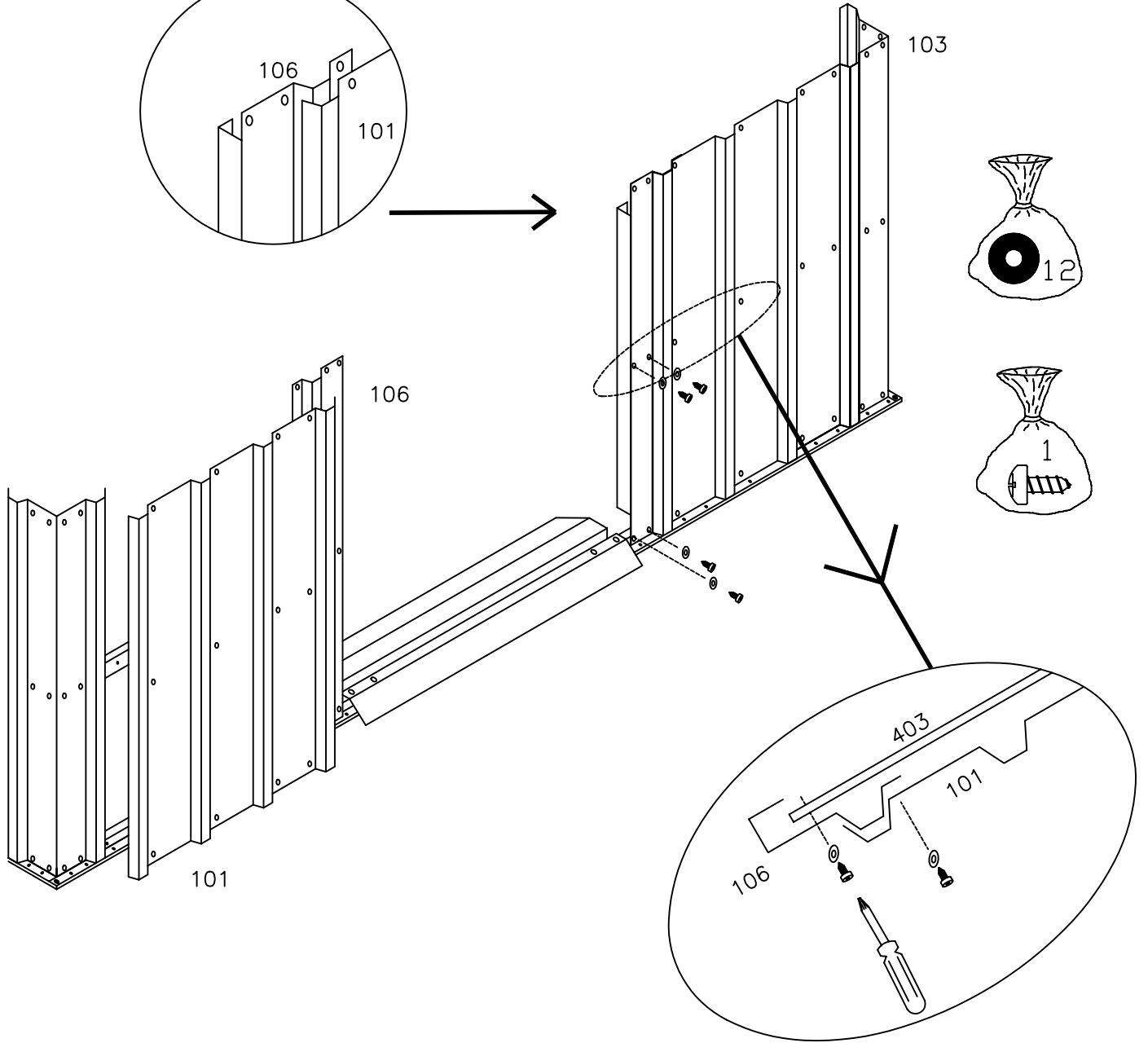
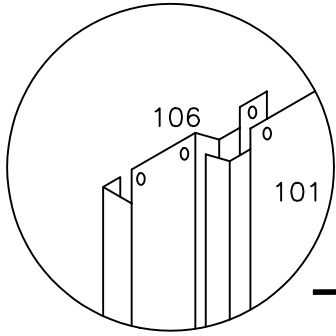
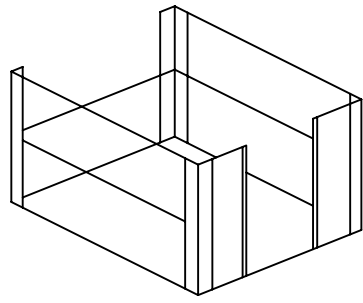

WALL PANEL ASSEMBLY
 MONTEREN VAN WANDPANEEL
 MONTAGE DE LA PANNEAU MURAL
 WANDPLATTEN MONTAGE
 PAINEL DA PAREDE
 PANELES DE LA PARED

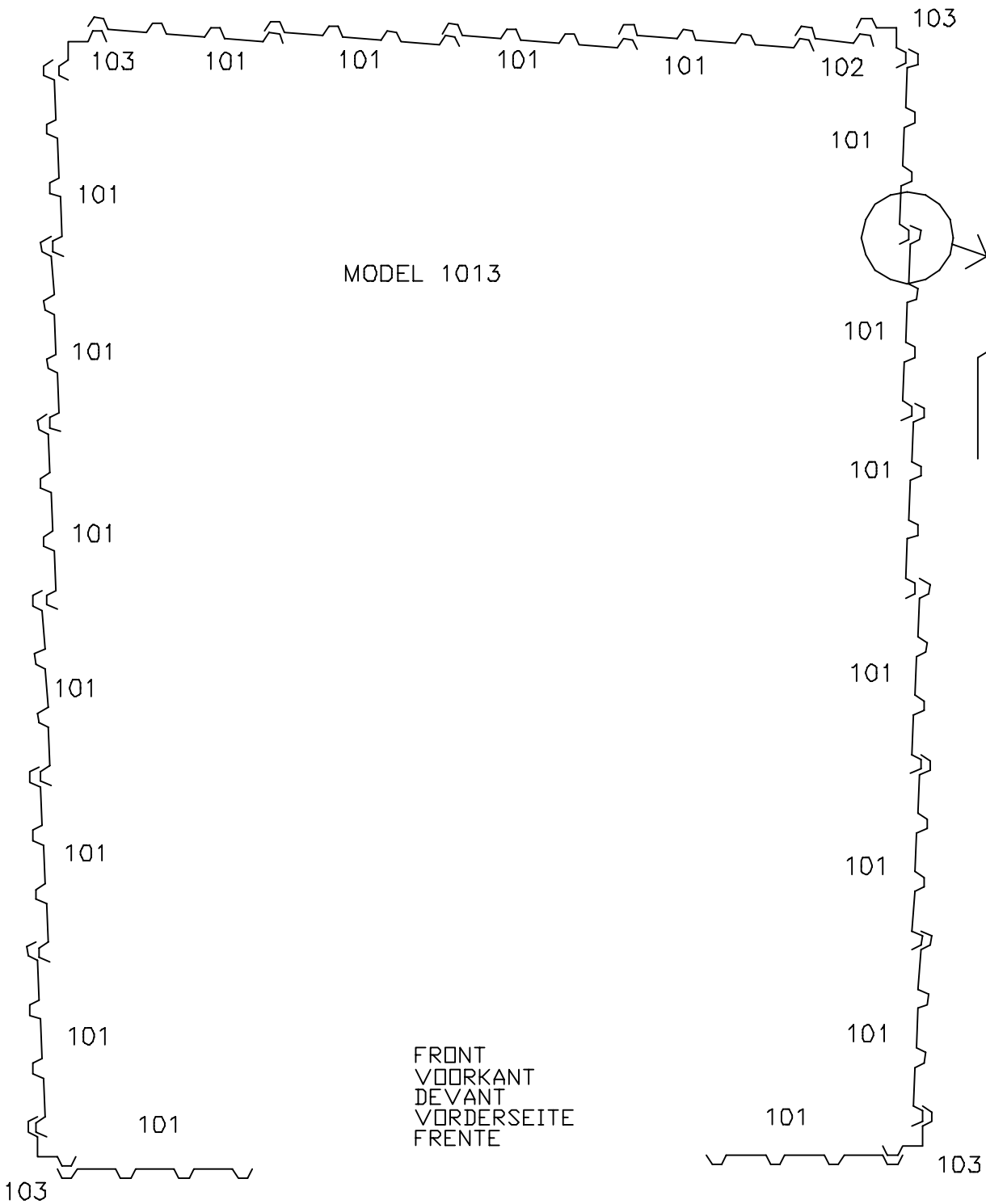
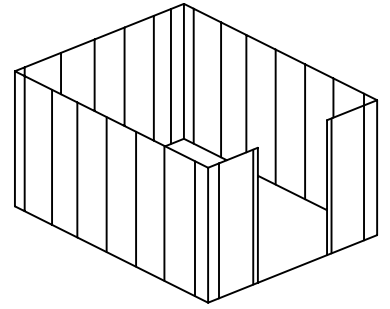
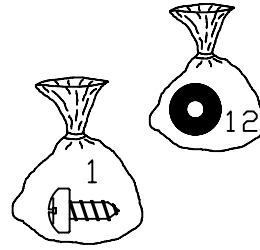

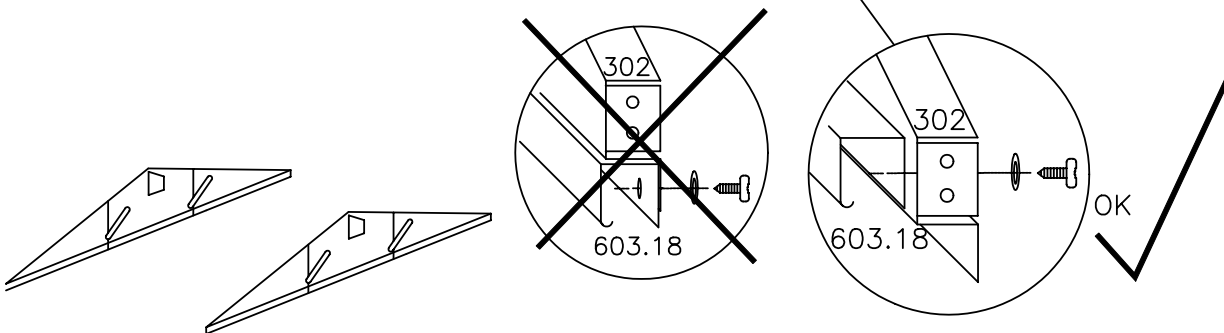
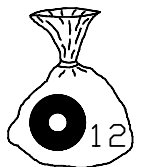
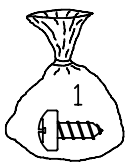
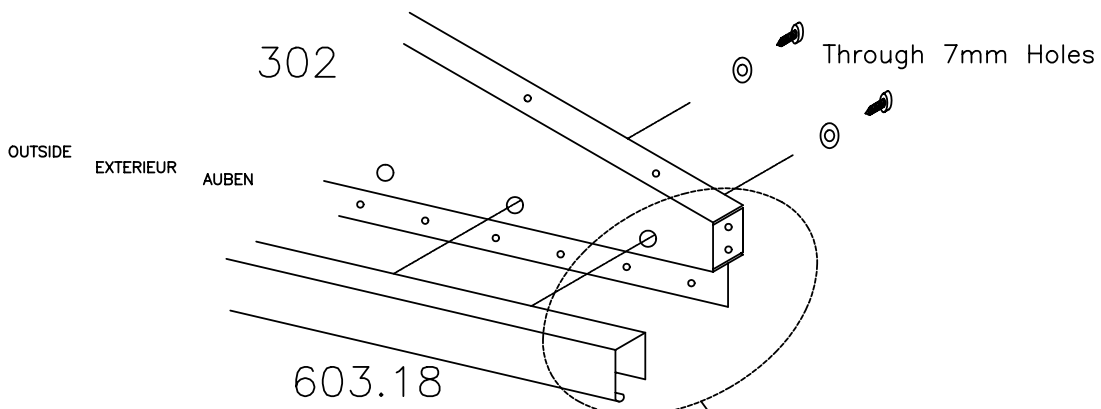
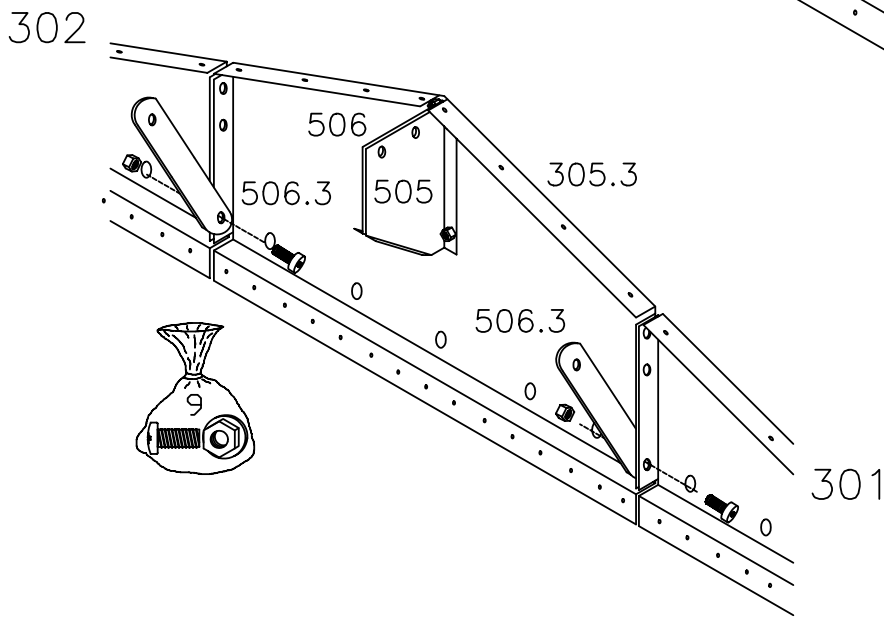
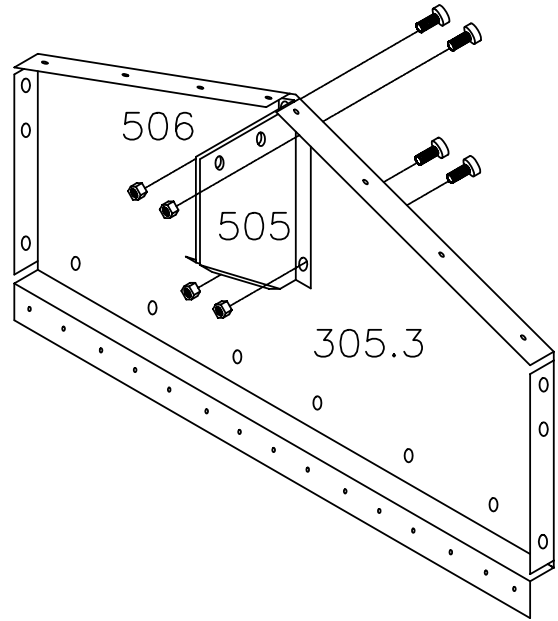
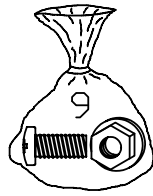

FRONT GABLES
 GEVELTOP-VOORKANT
 FACHADA FRONTAL
 PIGNON-AVANT
 GIEBEL-VORNE
 EMPENA FRONTAL

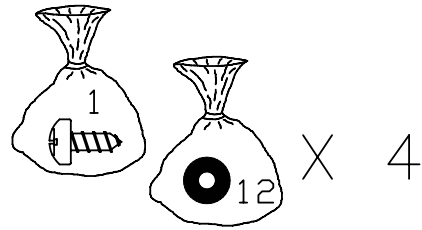

USE 4 SCREWS ONLY

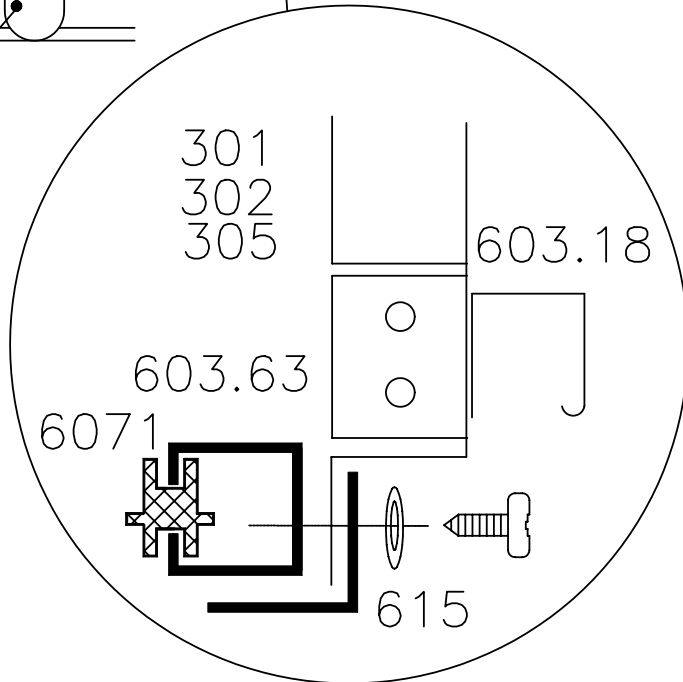
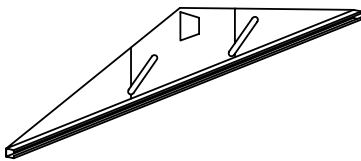
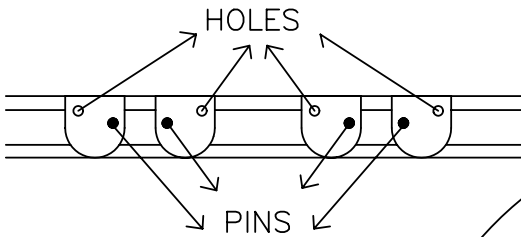
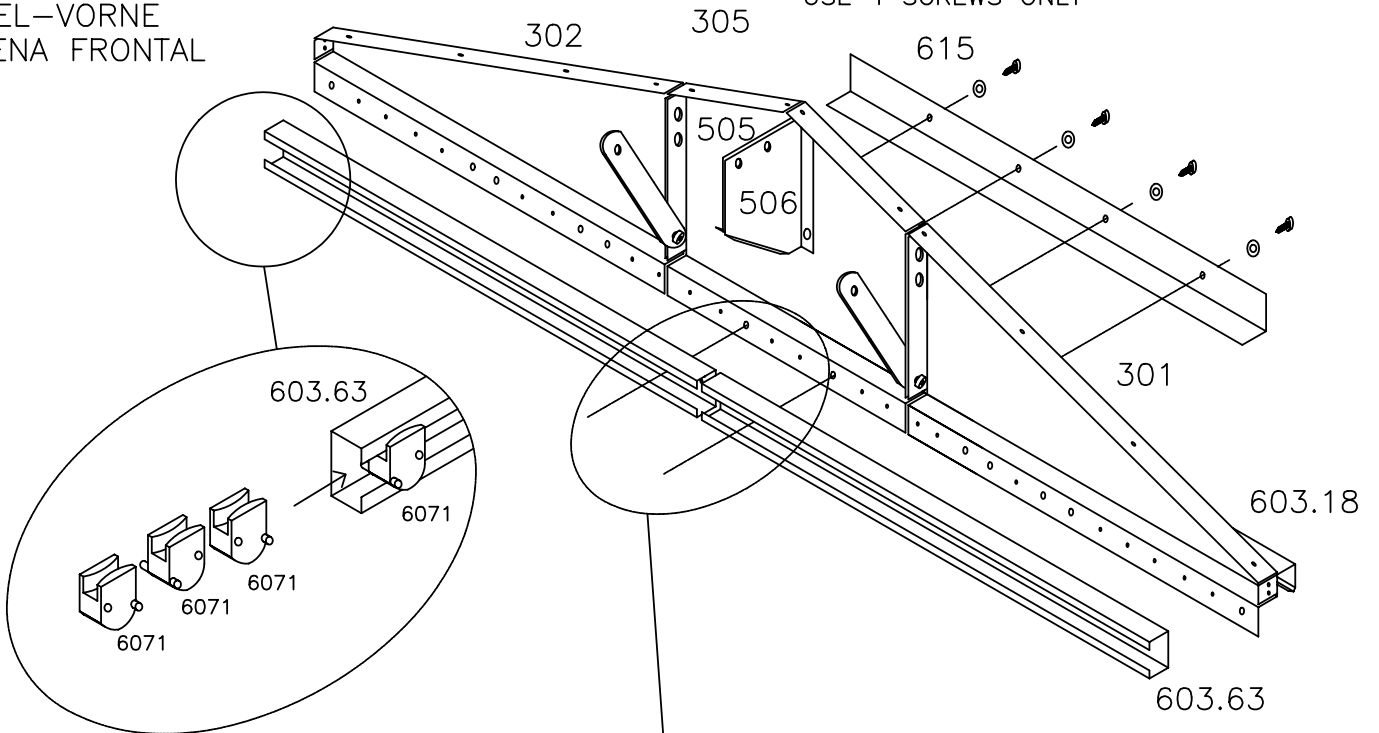

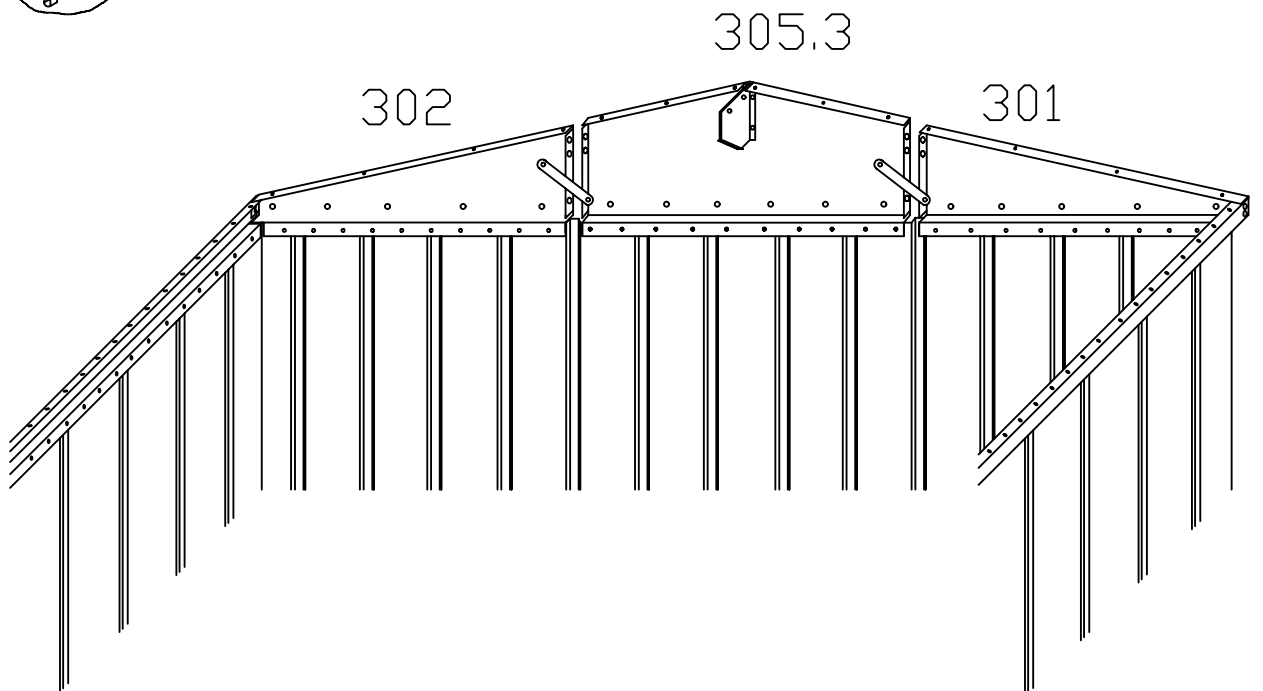
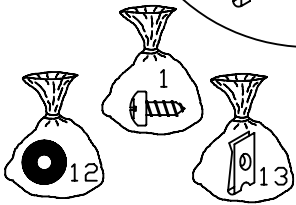
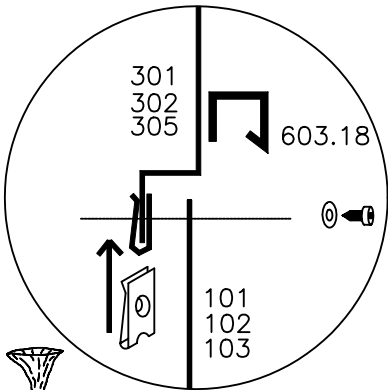
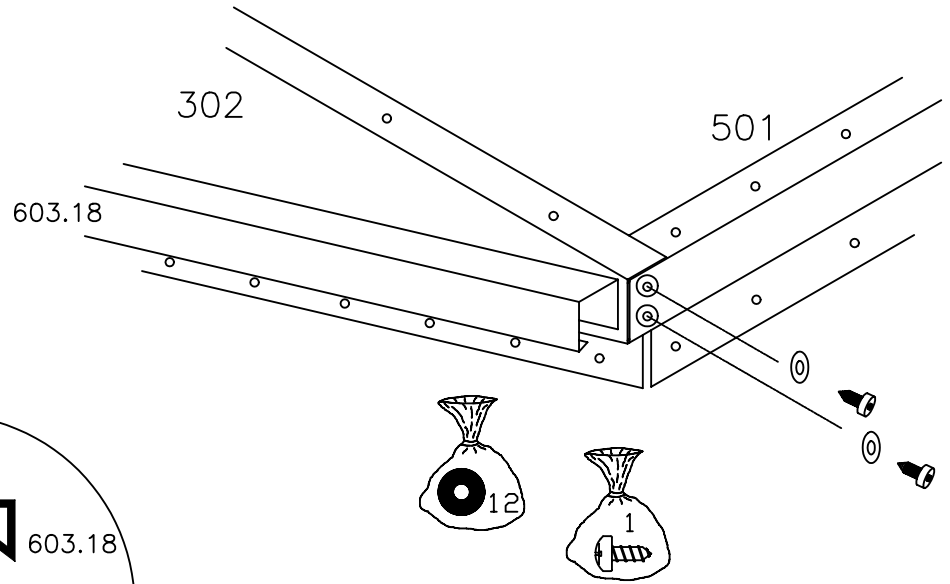
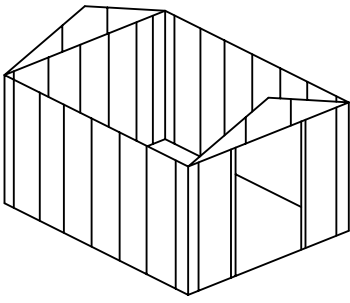

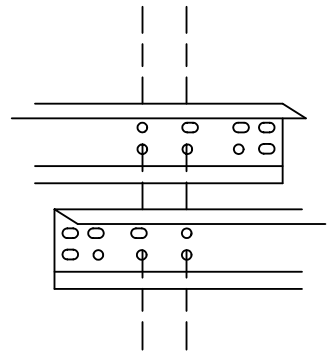

233 mm Overlap

X 3

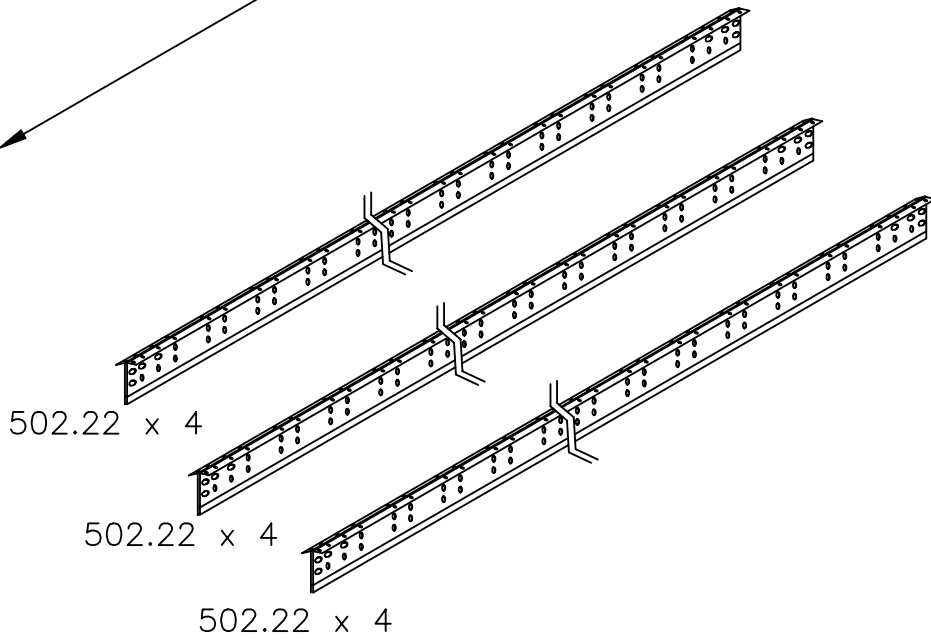
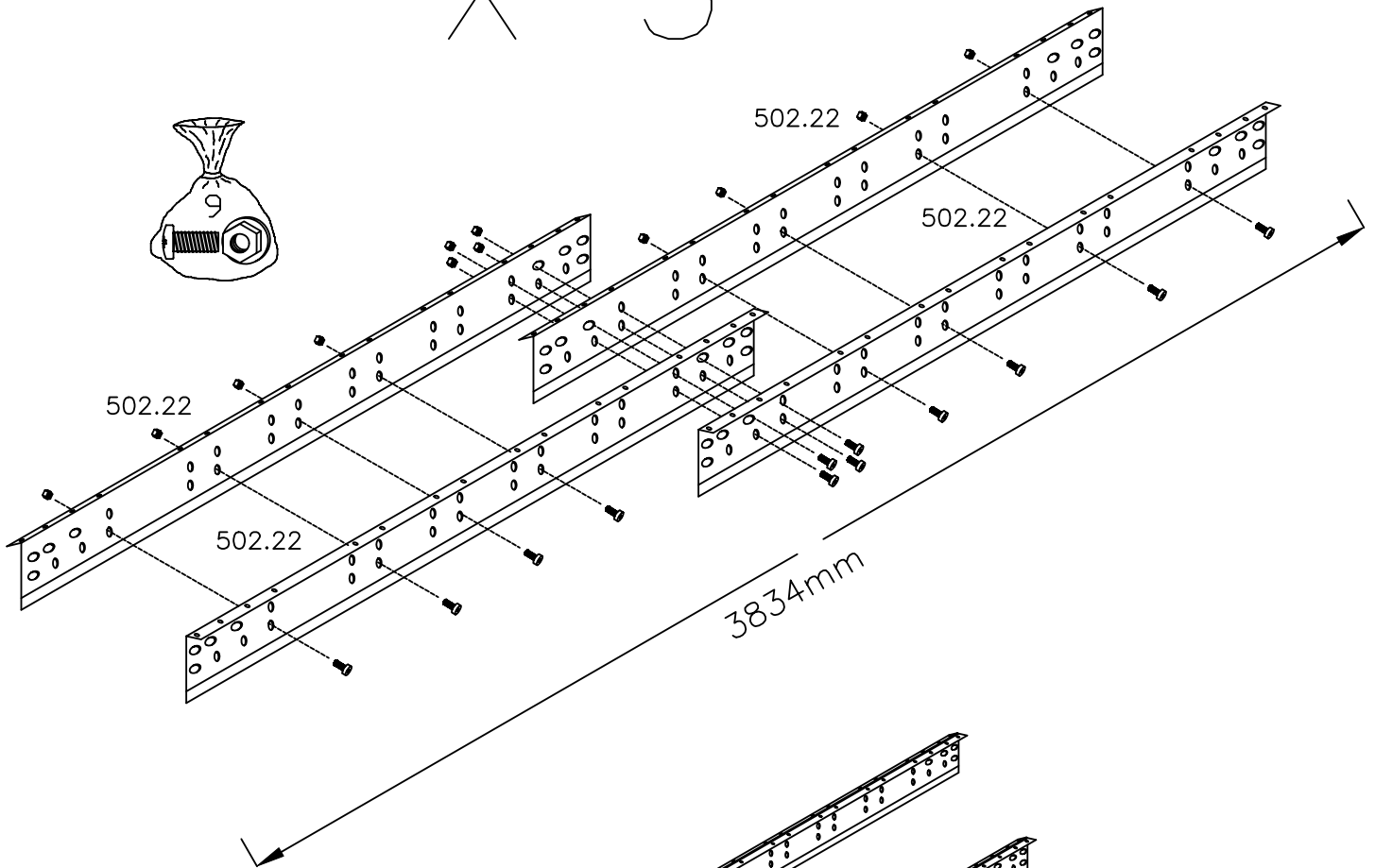
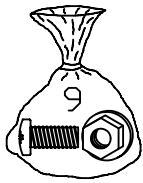

FRONT GABLES
 GEVELTOP-VOORKANT
 FACHADA FRONTAL
 PIGNON-AVANT
 GIEBEL-VORNE
 EMPENA FRONTAL

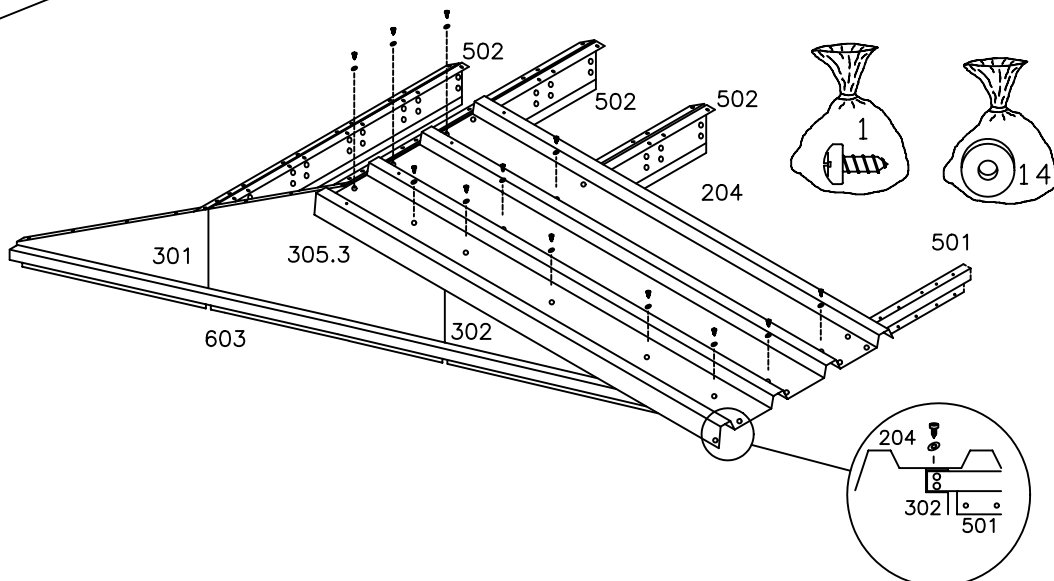
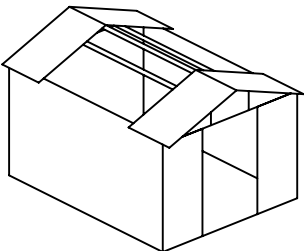
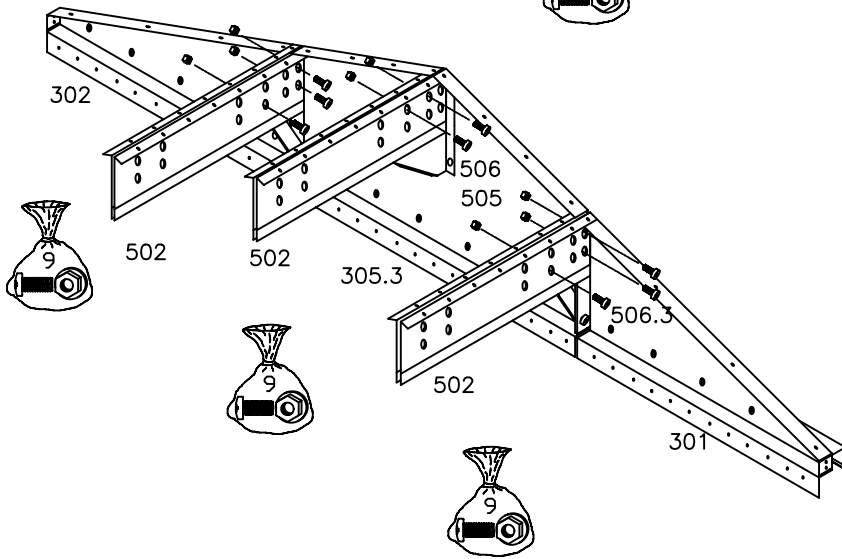
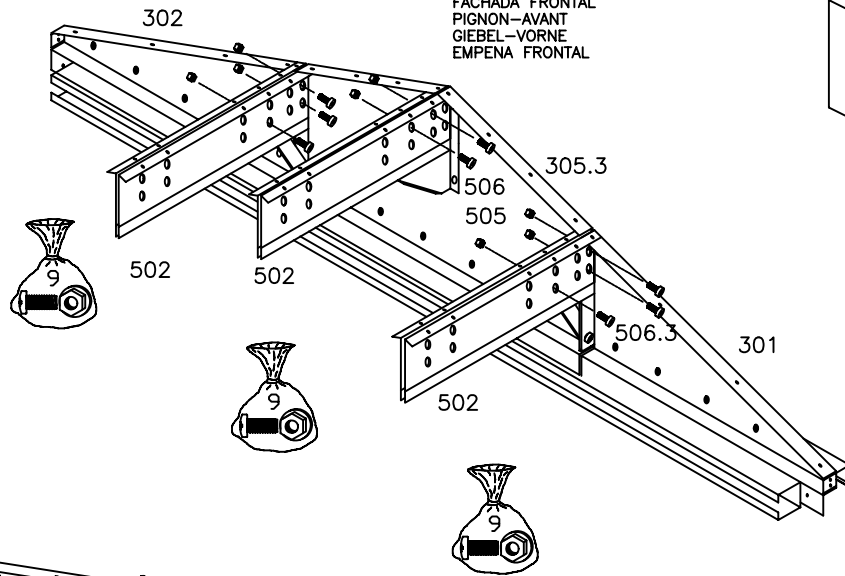
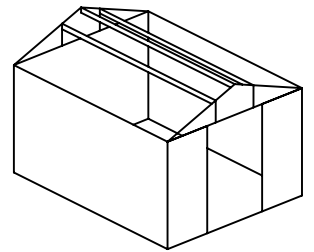

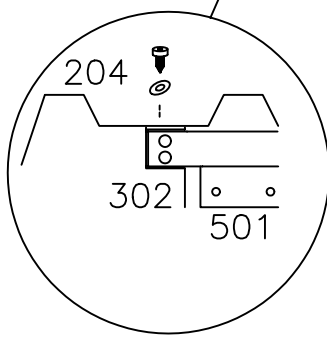
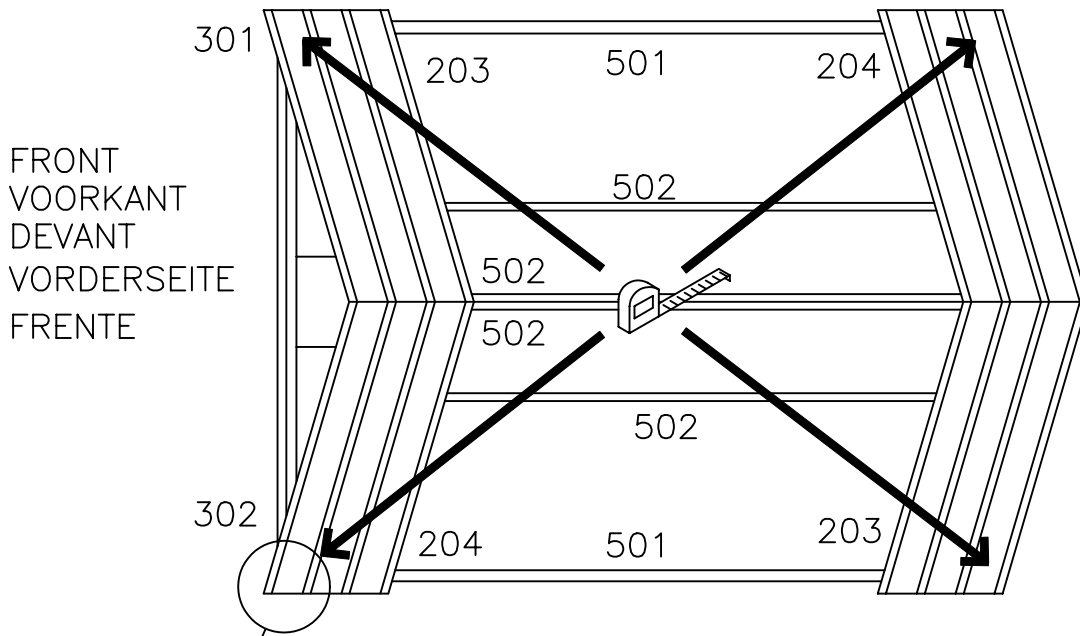

ENSURE ROOF FRAME
IS "SQUARE" BEFORE
SECURING PANELS

EQUARREZ LE METIER
AVANT DE FIXER
LES PANNEAUX

DACHRAHMEN RECHTWINKLIG
VOR DACHPLATTEN
FESTZUMACHEN

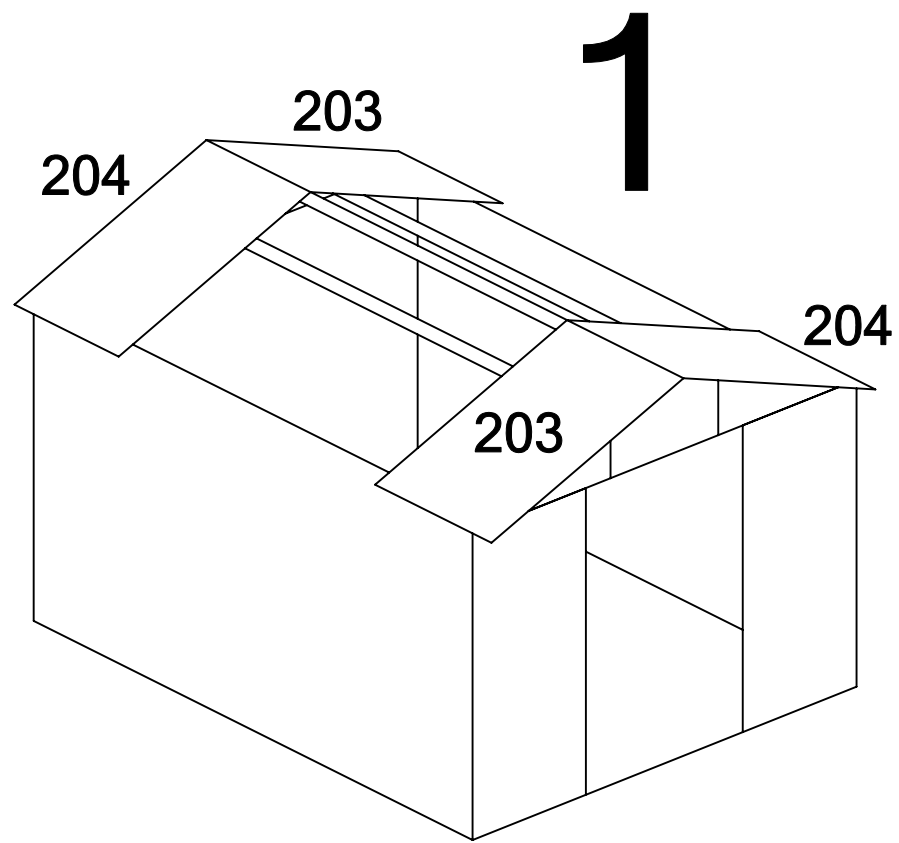

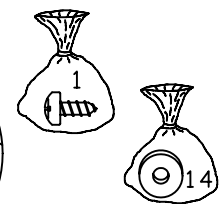
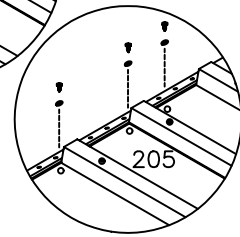
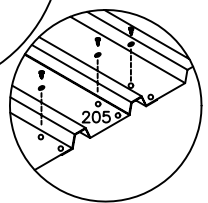
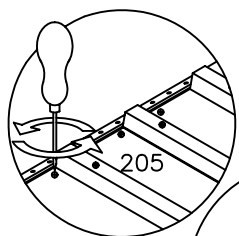
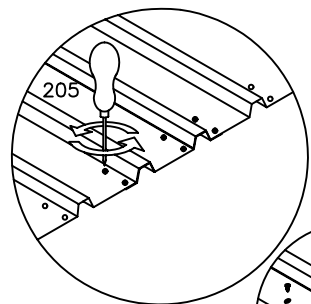
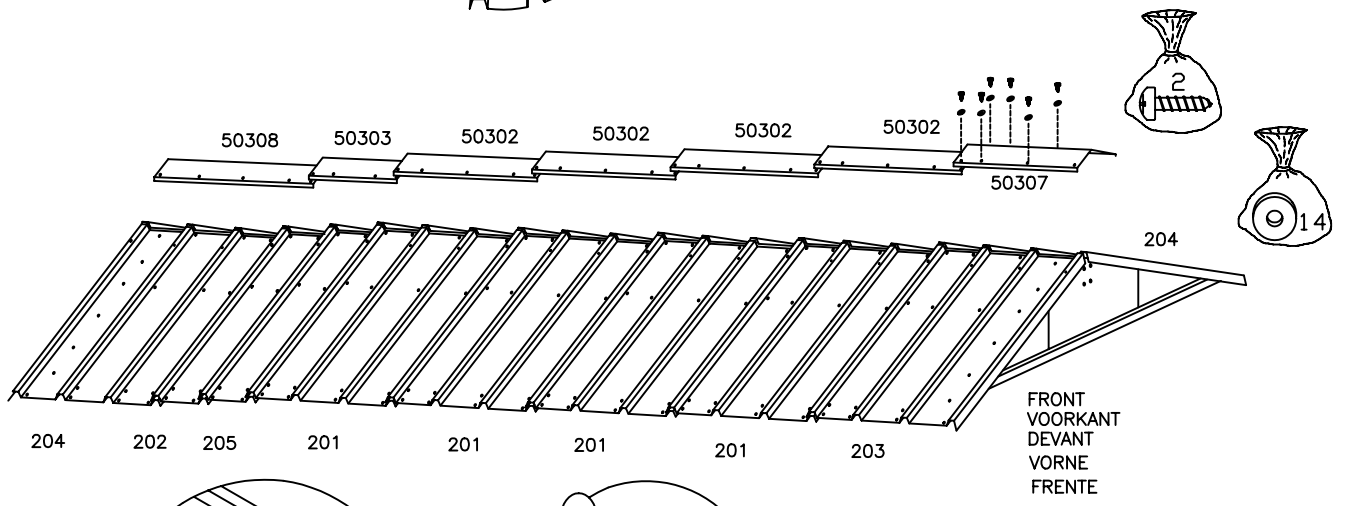
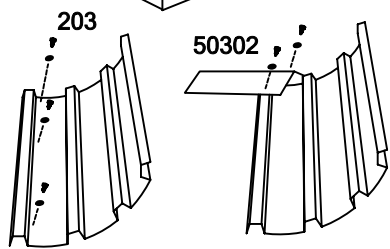
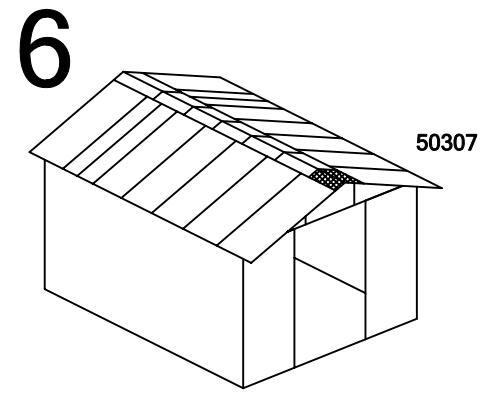
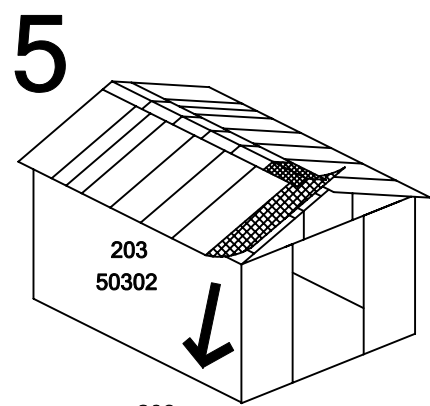
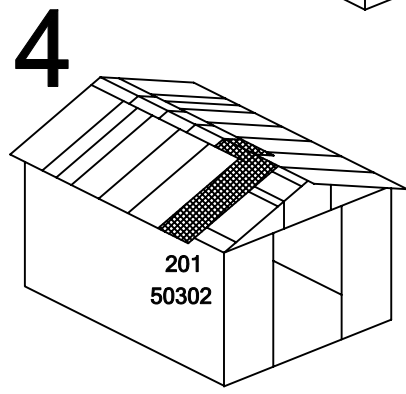
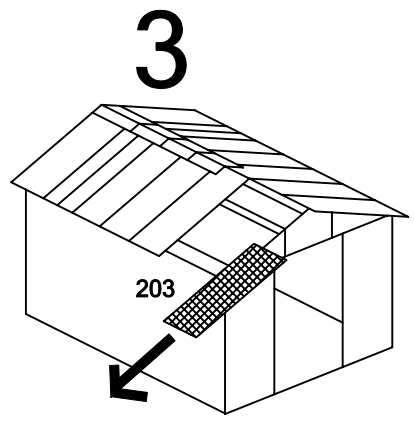
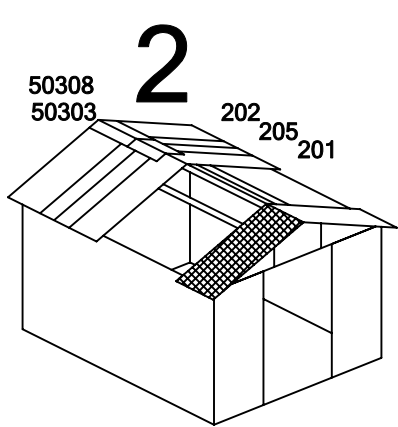

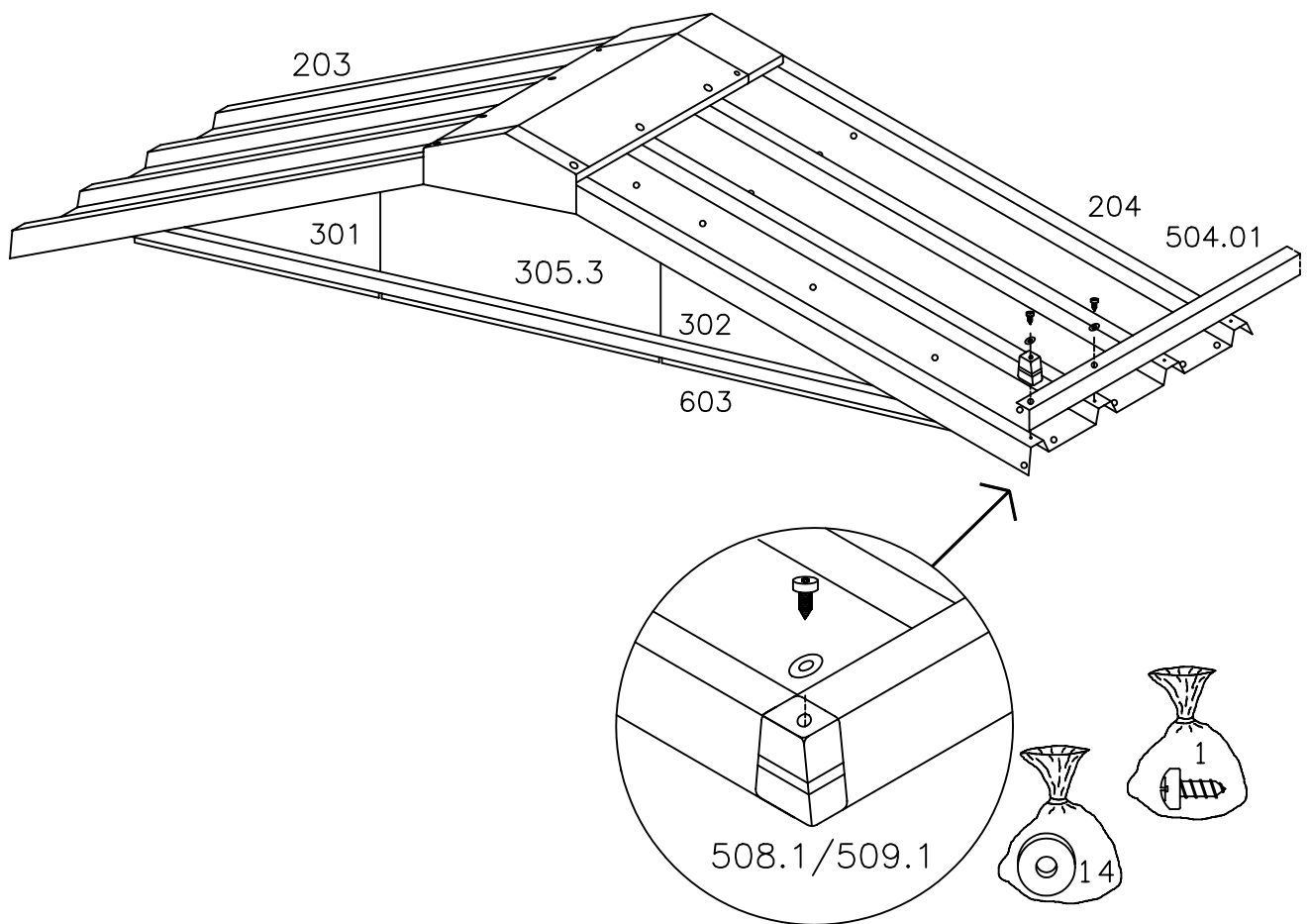
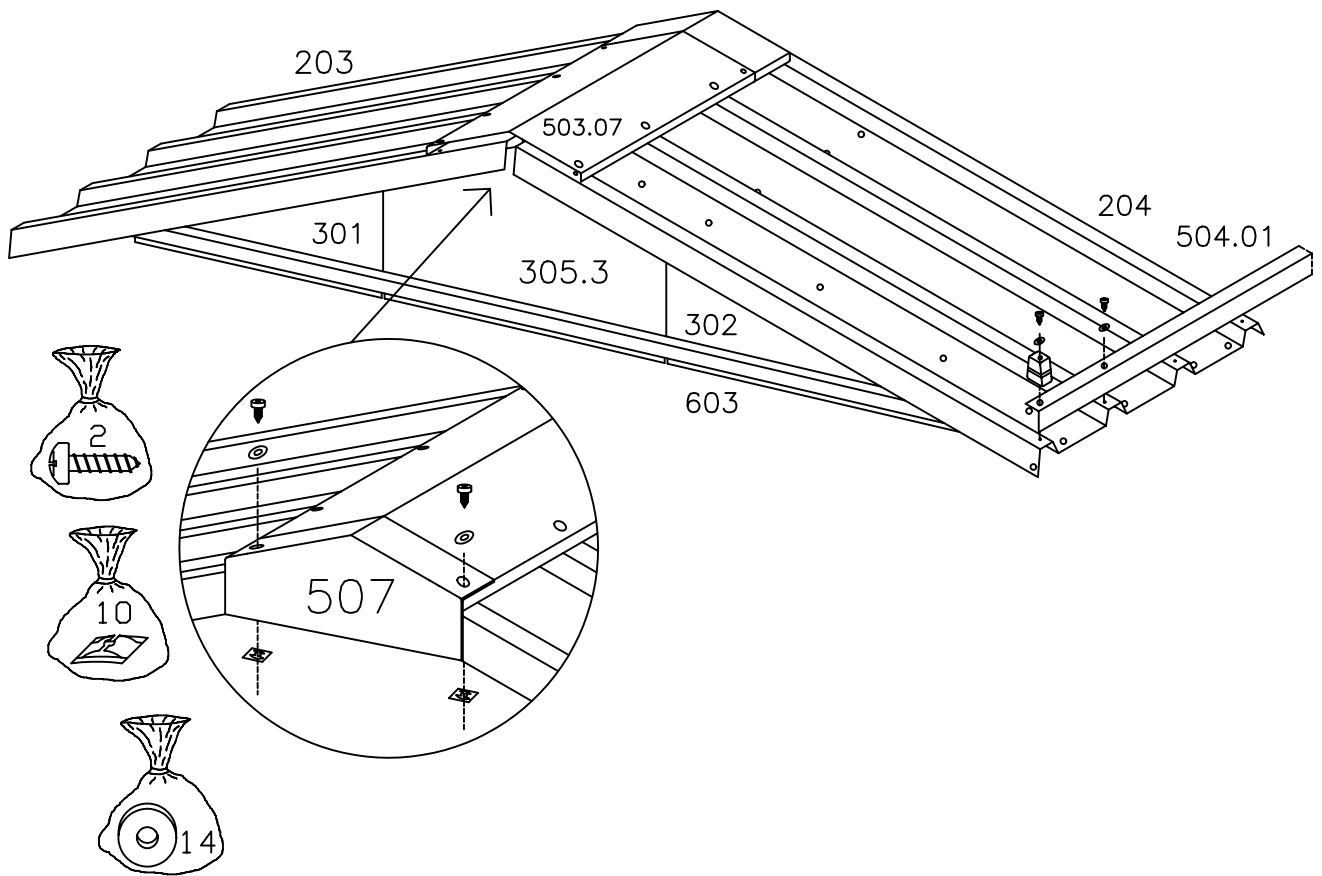

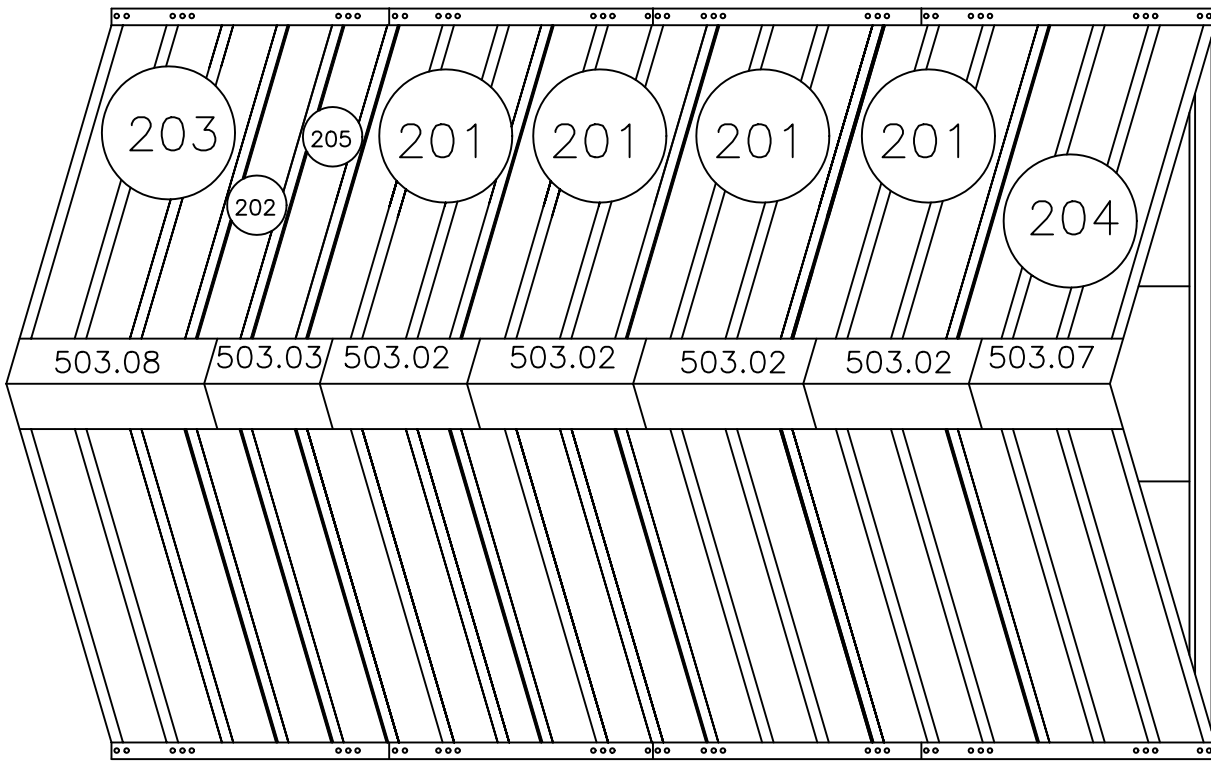

FRONT
 VOORKANT
 DEVANT
 VORDERSEITE
 FRENTE
 MODEL 1013

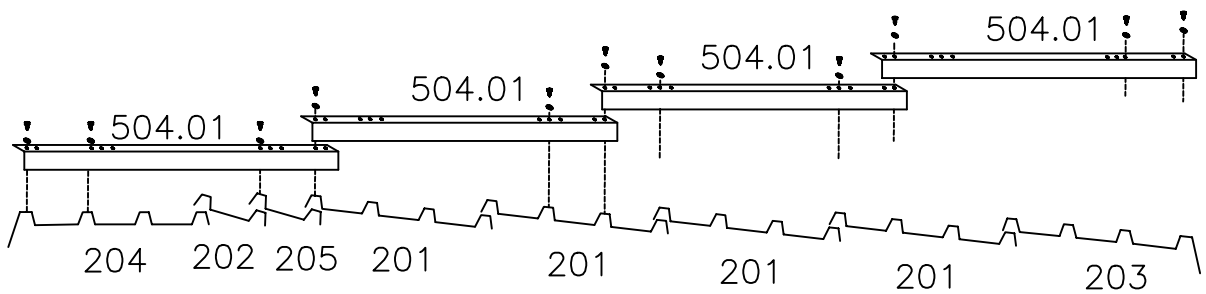
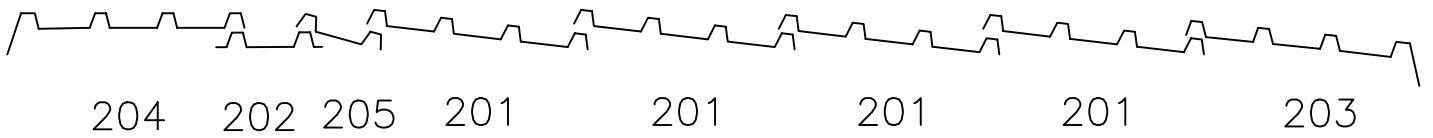

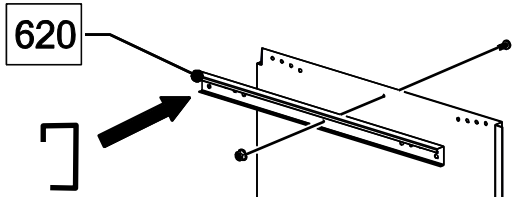
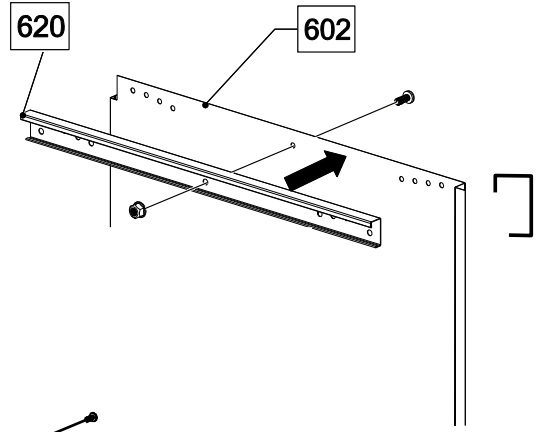
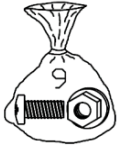

602



609

601

INSIDE
A L'INTERIEUR
INNENSEITE

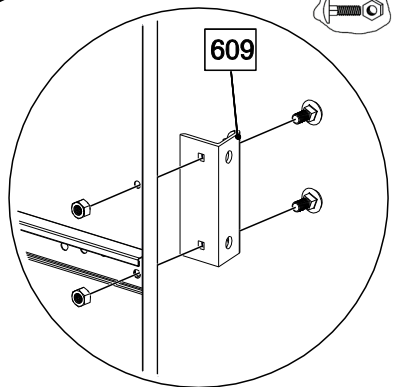
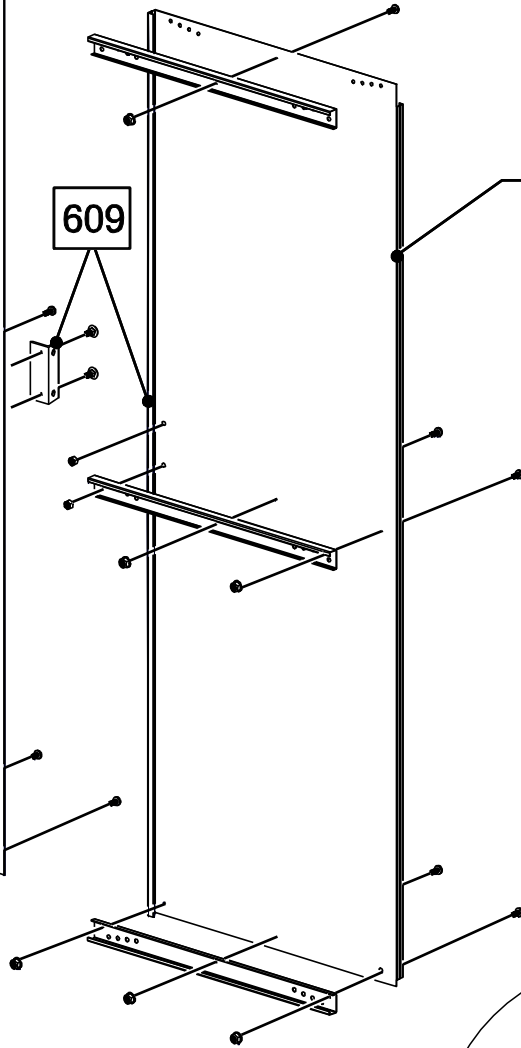
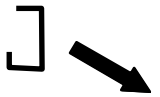

602

609

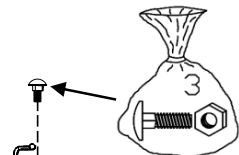
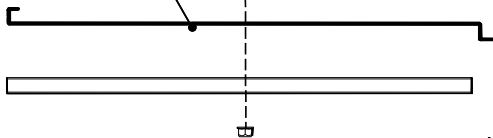

601

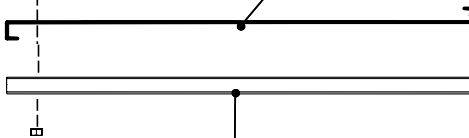

INSIDE
A L'INTERIEUR
INNENSEITE

620

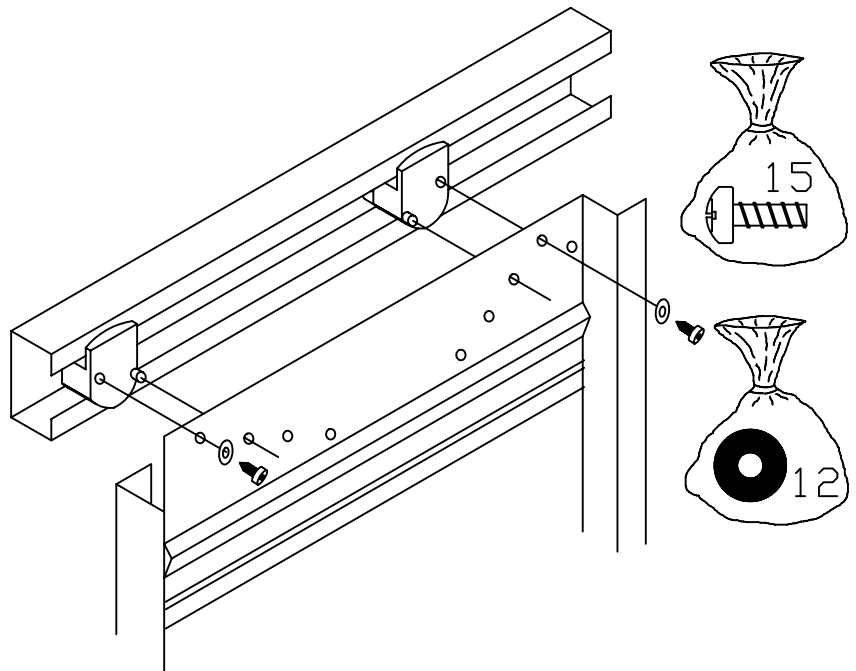
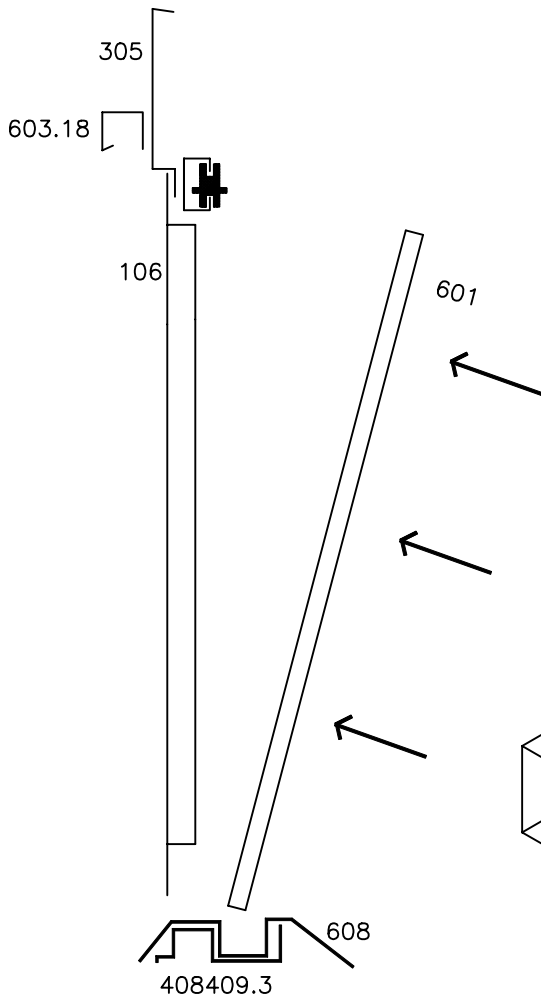
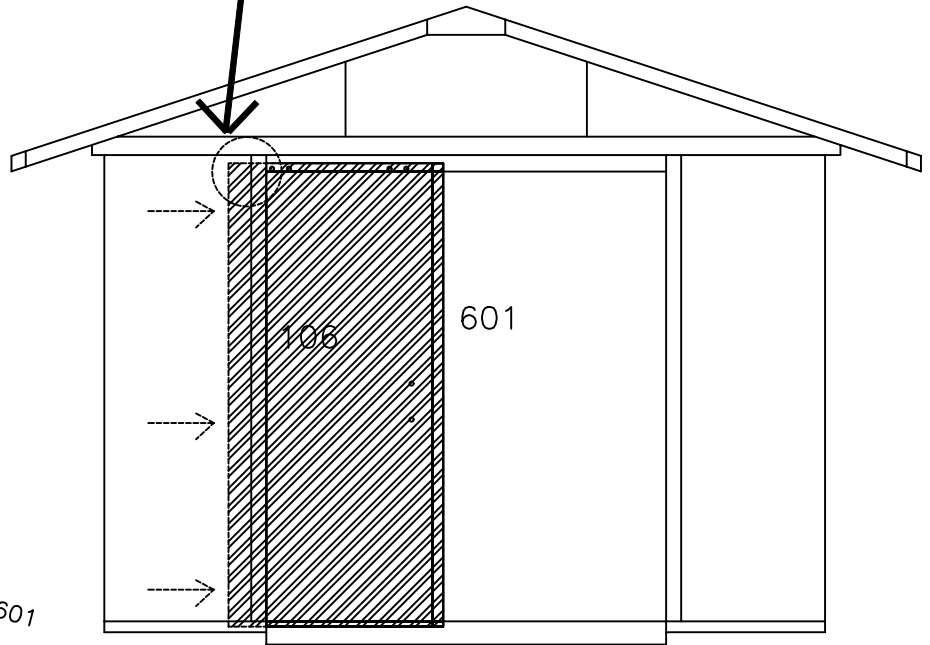
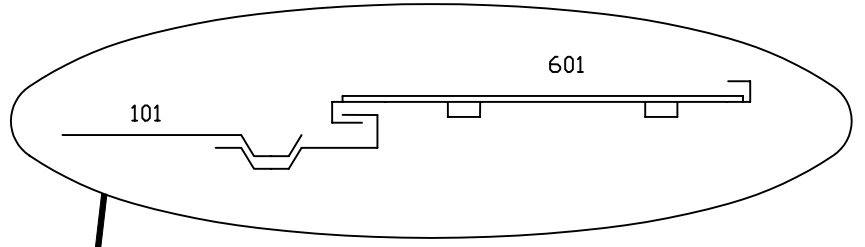
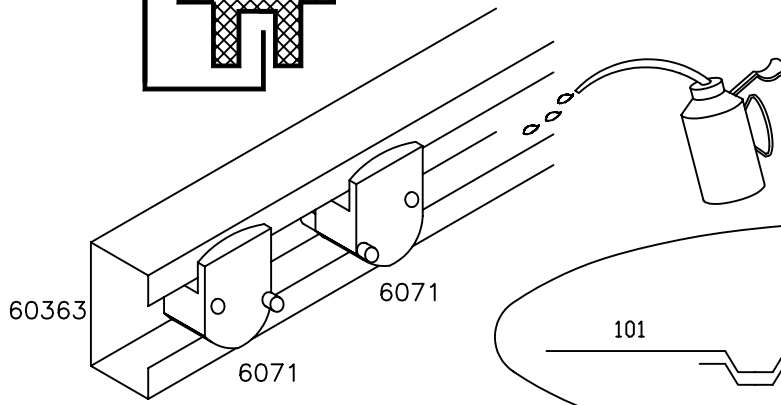
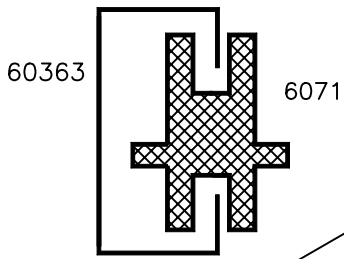

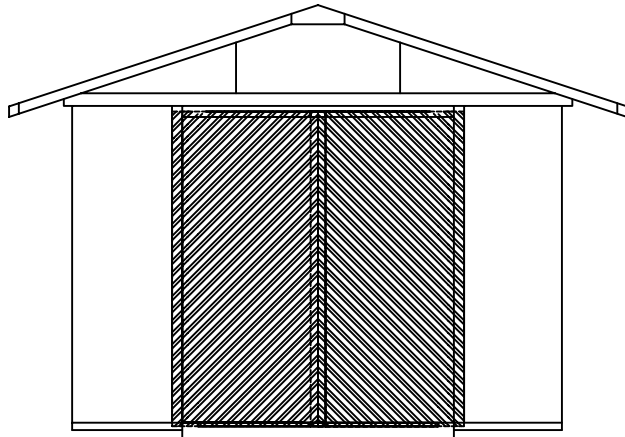
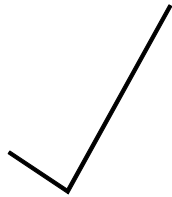
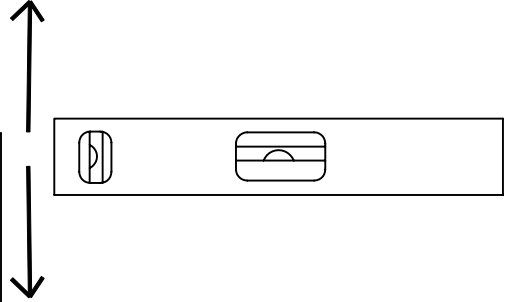
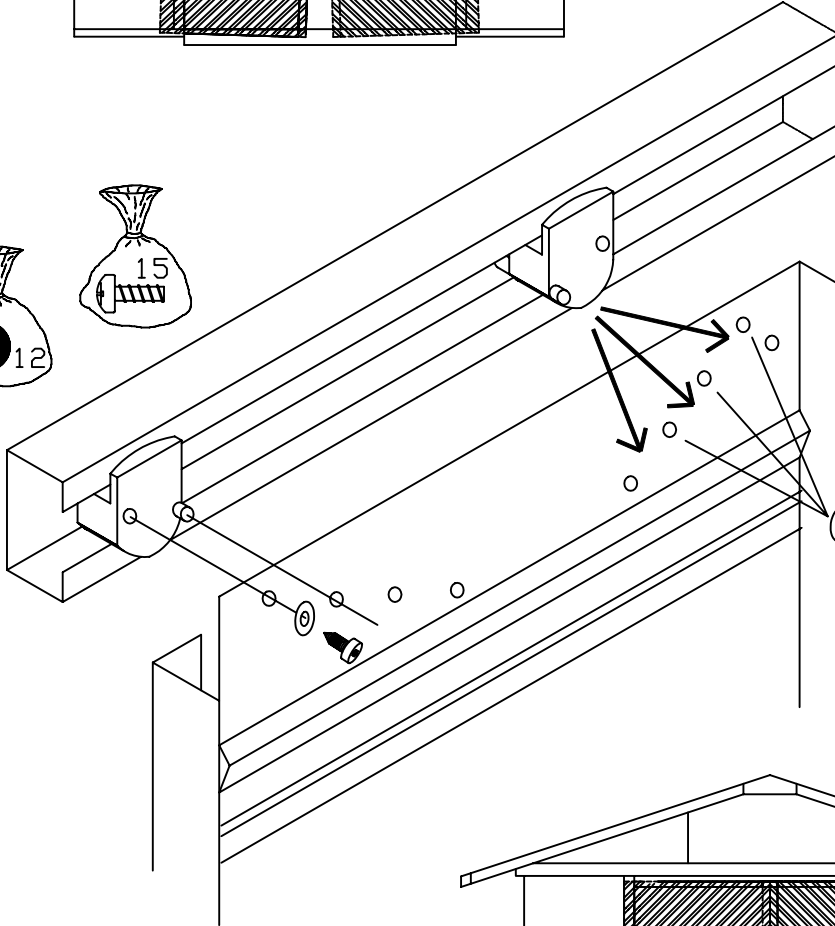
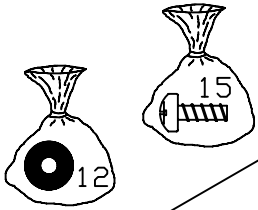
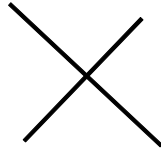
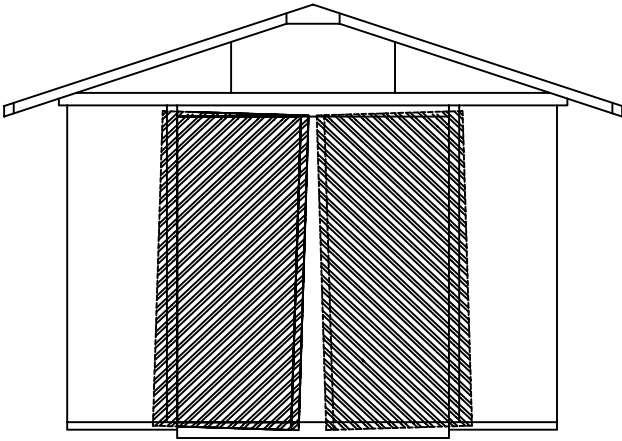

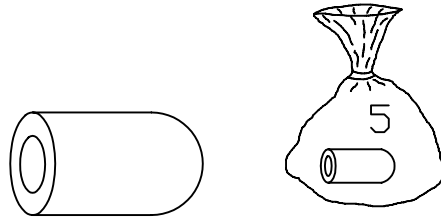
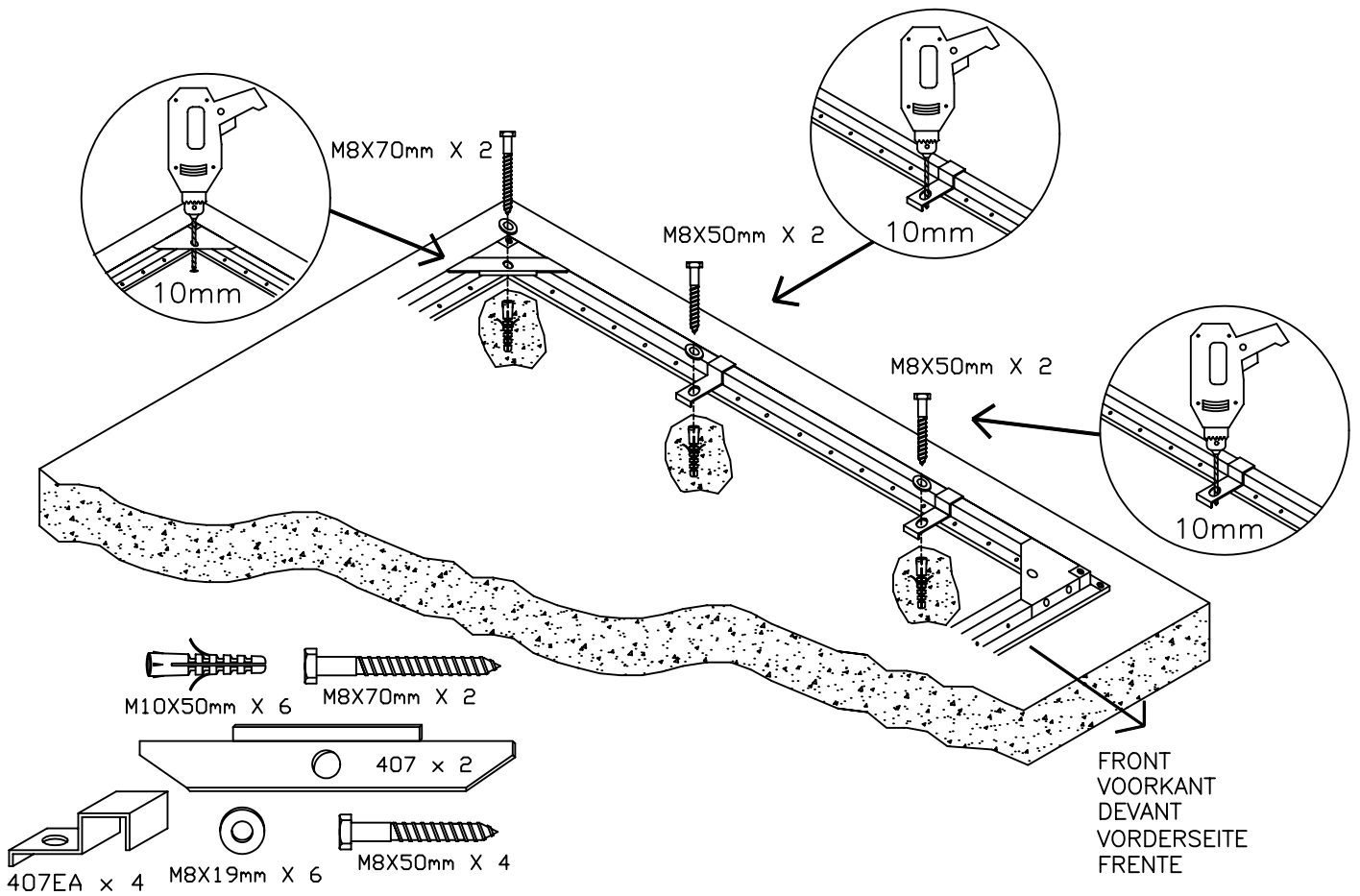

- BAG NO. 5 PLASTIC TIPS USED ON EXPOSED SCREW POINTS
ON INSIDE WALLS
- SAC NO. 5 CAPUCHONS EN PLASTIQUE POUR POINTES DE VIS
NUES SUR LES PAROIS INTERIEURES
- BEUTEL NO. 5 PLASTIK-AUFSTECKHUTCHEN FÜR DIE
SCHRAUBENSPIITZEN AN DEN INNENWANDEN
- ZAK NO. 5 PLASTIC DOPJES VOOR SCHROEFUITEINDEN AAN
DE BINNENWAND
- BOLSA NO. 5 TAPONES DE PLASTICO PARA UTILIZAR EN PUNTOS DONDE
QUEDE EXPUESTO EL TORNILLO EN LAS PAREDES INTERIORES
- SACO NO. 5 PONTEIRAS PLASTICAS PARA PONTAS DE PARAFUSOS
EXPOSTAS NAS PAREDES INTERIORES